

S Series

Helical Worm Gear Units

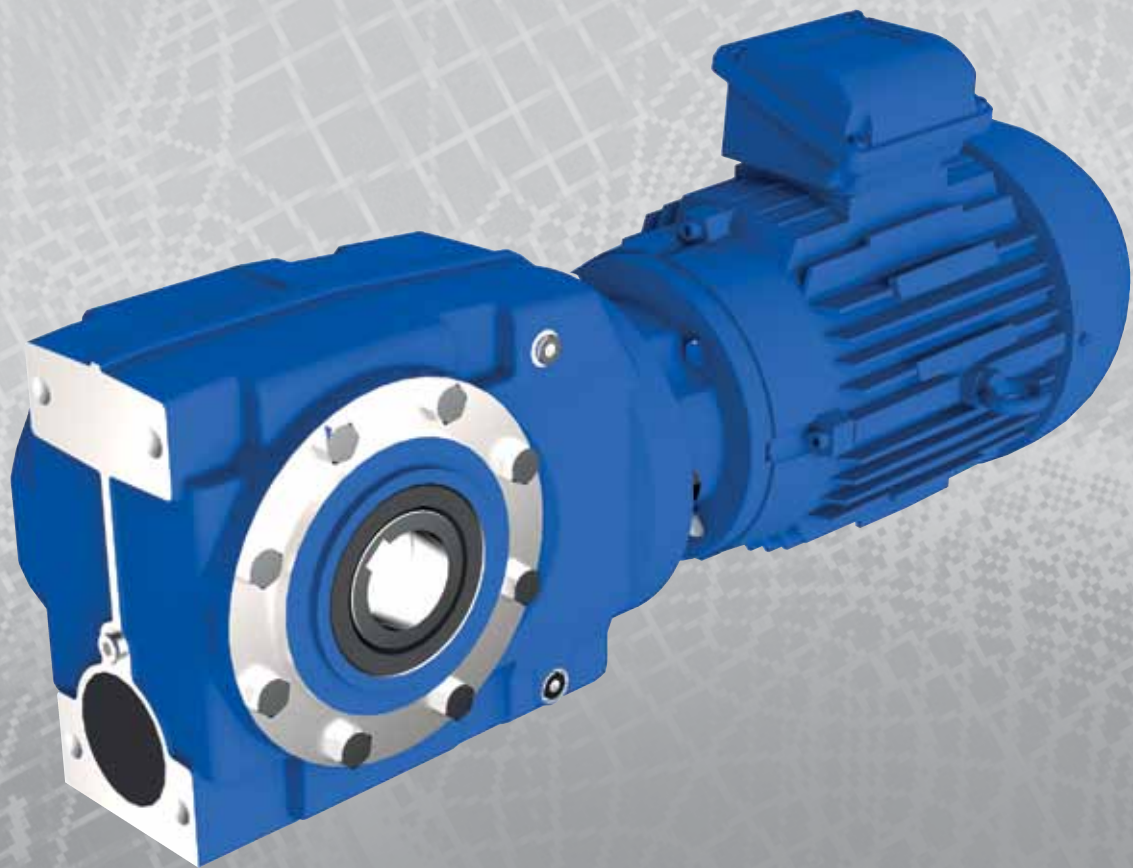

RENOLD
Superior Gear Technology

ATEX Compliance Assured



Total compliance with the ATEX Directive safeguarding the use of industrial equipment in potentially explosive atmospheres is assured for users of our geared products.

Certification is available for standard gearboxes and geared motors with badging displaying the CE Mark and the Ex mark, name and location of the manufacturer, designation of series or type, serial number, year of manufacture, Ex symbol and equipment group/category.

ATEX directive 94/9/EC (also known as ATEX 95 or ATEX 100A) and the CE Marking Directive are enforced in all EC member states. Compliance is compulsory for designers, manufacturers or suppliers of electrical and non-electrical equipment for use in potentially explosive atmospheres created by the presence of flammable gases, vapours, mists or dusts.

Ex compliant standard gearboxes can be supplied against Groups 2 or 3 for surface industries in designated hazardous location Zones 1 and 2 for gases, vapours and mists; and in Zones 21 and 22 for dusts.

S SERIES

CONTENTS

General Description _____	2
Unit Designations _____	3
Explanation and use of Ratings and Service Factors _____	4
Load Classification by Applications _____	5
Selection Procedure _____	6 - 7
Output Options _____	8 - 9
Motor Adaptors _____	10 - 12
Lubrication _____	13
Mounting Positions _____	14
Unit Handlings _____	15
MOTORISED	
Motor Performance Data and Standard Motor Variants Available _____	18
Motor Details _____	19
Additional Motor Features _____	20
Additional Gearbox Features _____	21
Selection Tables - Geared Motors _____	22 - 61
Dimension Sheets - Geared Motors _____	62 - 69
Dimensions Output Options _____	70
Motorised Backstop Module _____	71
REDUCER	
Overhung & Axial Loads on Shafts _____	74
Ratings - Input Power / Output Torque _____	75 - 82
Dimension Sheets - Speed Reducers _____	83 - 88
Dimension Sheet - Units fitted with Feet _____	89 - 90
Thermal Power Ratings / Dimensions of Unit with Fan _____	91 - 92
Reducer Backstop Module _____	93
OUTPUT OPTIONS	
Dimensions of Outputshaft Options _____	94
Dimension Sheet - Torque Bracket _____	95
Dimensions of B5 (D) Flange units _____	96
Dimensions of B14 (C) Flange units _____	97
Agitator Units _____	98
Dimension Sheet - Assembly / Disassembly _____	99 - 100
Shipping Specification _____	101
Product Safety Data _____	103

S SERIES

GENERAL DESCRIPTION

S Series

Right angle helical worm geared motors and reducers provide a highly efficient and compact solution to meet most requirements up to 45 kW with maximum output torque capacity of 10,000Nm.

Following a long line of power transmission products, this product adds to the growing family of new drives which has taken advantage of our many years of accumulated design expertise, together with the use of high quality materials and components. The end result is a series of speed reducing and geared motors offering high load carrying capacity, increased efficiency, quiet running and reliability.

The Range Includes

Eight sizes of units with a ratio coverage of 8:1 to 250:1 in double reduction and 16000:1 in combined units.

- Version W - Standard Unit (S03 - S06 Only)
- Version B - Standard Unit with Base Mounted Feet
- Version E - Standard Unit with End Mounted Feet
- Version R - Standard Unit with Top Mounted Feet
- Version V - Standard Unit with Drywell and Output Flange for Mounting Positions 2 & 3 (sizes S07 -S10 only)
- Version F/H - Standard Unit with Output Flange
- Version G - Standard Unit with Output Flange Reduced Diameter (size R03 only)
- Version T/Q - Standard Unit with Torque Arm
- Version U - Standard Unit Torque Arm Heavy Duty (S10 only)
- Version A - Agitator (Sizes S07 - S10 only)

Unit Types:

- Unit type M - Motorised with IEC Standard Motor
- Unit type D - Motorised with Compact Motor
- Unit type N - Motorised with NEMA Standard Motor
- Unit type H - Motorised with High Efficiency Motor (IE3)
- Unit type E - Motorised with NEMA High Efficiency Motor (PREMIUM)
- Unit type G - Unit to Allow Fitting of Customers IEC Motor
- Unit type A - Unit to Allow Fitting of Customers NEMA Motor
- Unit type R - Reducer Unit
- Unit type S - Reducer Unit with Fan Kit
- Unit type W - Reducer Unit with Backstop CCW Rotation
- Unit type X - Reducer Unit with Backstop CW Rotation
- Unit type Y - Reducer Unit with Fan and Backstop CW Rotation
- Unit type Z - Reducer Unit with Fan and Backstop CCW Rotation

Design Features Include

Patented standard motor connection (IEC or NEMA).

Ability to fit double oil seals input and output as required.

All units are dimensionally interchangeable with other major manufacturers.

Brake geared motors are available as standard.

Sizes 03, 04, 05 and 06 are lubricated for life.

Motorised units can be fitted with a backstop module and reducer units can be fitted with a backstop and fan.

Units are manufactured and assembled from a family of modular kits for distributor friendliness minimising inventory and maximising availability.

As improvements in design are being made continually this specification is not to be regarded as binding in detail and drawings and capacities are subject to alteration without notice. Certified drawings will be sent on request.

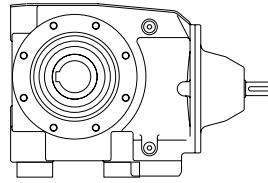

Two stage reduction unit with base mounted feet and hollow output shaft

* S 0 4 2 1 1 8 . B R H - 1 - - - - - - - -

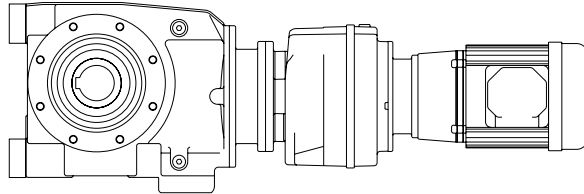

Four stage motorised unit with end mounted feet and hollow output shaft

* S 0 4 4 1 2 8 0 E M H - 1 A . 1 8 A - -

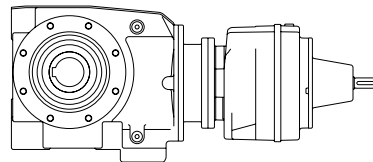

Four stage reduction unit with hollow output shaft

* S 0 5 4 1 2 8 0 W R H - 1 - - - - - - - -

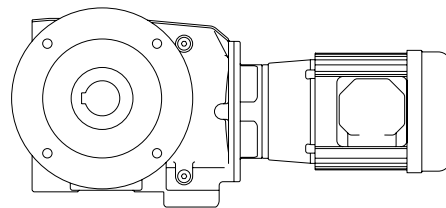

Two stage motorised unit with output flange and single extension output shaft

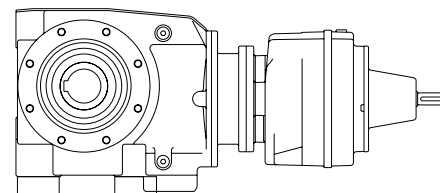

Four stage reduction unit with base mounted feet and hollow output shaft

* S 0 4 4 1 2 8 0 B R H - 1 - - - - - - - -

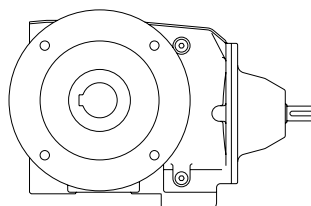

Two stage reduction unit with output flange and single extension output shaft

* S 0 5 2 1 1 6 0 F R C - 1 - - - - - - - -

* Typical unit designations

S SERIES

Gear codes										Motor codes									
1	2	3	4	5	6	7	8	9	10	11	12	13	14	15	16	17	18	19	20
* <input type="text" value="S"/>																			
Example <input type="text" value="S"/> <input type="text" value="0"/> <input type="text" value="3"/> <input type="text" value="2"/> <input type="text" value="1"/> <input type="text" value="5"/> <input type="text" value="0"/> <input type="text" value="."/> <input type="text" value="B"/> <input type="text" value="M"/> <input type="text" value="C"/> <input type="text" value="-"/> <input type="text" value="1"/> <input type="text" value="D"/> <input type="text" value="."/> <input type="text" value="1"/> <input type="text" value="8"/> <input type="text" value="A"/> <input type="text" value="-"/> <input type="text" value="-"/>																			

1 - S Series
Range

2, 3 - Size of Unit
 Through

4 - No of Reductions

5 - Revision Version
 For Sizes 03 to 10

6,7,8 - Nominal Overall Ratio
eg.

9 - Unit Version

- Standard Unit (S03 - S06 Only)
 - Standard Unit with Base Mounted Feet
 - Standard Unit with End Mounted Feet
 - Standard Unit with Top Mounted Feet
 - Standard Unit with Drywell and Output Flange
 For Mounting Position 2 & 3 (Sizes S07 - S10 only)
 Std Unit with Output Flange on Left on Right
 - Std Unit with Output Flange Reduced Dia (S03 Only)
 Std Unit with Torque Arm on Left on Right
 - Std Unit with Torque Arm - Heavy Duty (S10 Only)

10 - Type of Unit

- Motorized with IEC standard motor
 - Motorized with Compact motor
 - Motorized with NEMA standard motor
 - Motorized with IEC high efficiency motor
 - Motorized with NEMA high efficiency motor
 - Unit to allow fitting of IEC motor (customer own motor)
 - Unit to allow fitting of NEMA motor (customer own motor)
 - Reducer unit
 - Reducer unit with fan kit
 - Reducer unit with backstop CCW rotation
 - Reducer unit with backstop CW rotation
 - Reducer unit with fan and backstop CW rotation
 - Reducer unit with fan and backstop CCW rotation

19 - Additional Motor Features
eg
For Types Without Motor Enter

18 - No of Motor Features

<input type="text" value="-"/>	No motor	<u>50 Hz</u>	<u>60 Hz</u>
<input type="text" value="A"/>	4 Pole (Std) 1500 rpm	<input type="text" value="A"/>	1800 rpm <input type="text" value="B"/>
<input type="text" value="K"/>	4 Pole (High) 1500 rpm	<input type="text" value="K"/>	1800 rpm <input type="text" value="L"/>
<input type="text" value="C"/>	6 Pole (Std) 1000 rpm	<input type="text" value="C"/>	1200 rpm <input type="text" value="D"/>
<input type="text" value="M"/>	6 Pole (High) 1000 rpm	<input type="text" value="M"/>	1200 rpm <input type="text" value="N"/>
<input type="text" value="E"/>	2 Pole 3000 rpm	<input type="text" value="E"/>	3600 rpm <input type="text" value="F"/>
<input type="text" value="G"/>	8 Pole 750 rpm	<input type="text" value="G"/>	900 rpm <input type="text" value="H"/>

Dual Speed or Special Motor

15, 16, 17 - Geared Motor Powers
Motor Power Required
eg
For Reducer or Non-Standard
Motor Types Enter

13, 14 - Mounting Position
eg

12 - Motor Adaptor For Unit Types
Column 10 Entries M, N, H, E, G or A
For All Other Types Enter

11 - Output Shaft

Standard Single Extension on Left on Right
 Standard Double Extension

Standard Hollow Shaft
 Unit with Hollow Shaft with Reduced Bore Dia
 Heavy Duty Single Extension (Size S06)
 Heavy Duty Double Extension (Size S06)

* This page may be photocopied allowing the Customer to enter their order

S SERIES

EXPLANATION & USE OF RATINGS & SERVICE FACTORS

Gear unit selection is made by comparing actual loads with catalogue ratings. Catalogue ratings are based on a standard set of loading conditions, whereas actual load conditions vary according to type of application. Service Factors are therefore used to calculate an equivalent load to compare with catalogue ratings.

i.e. Equivalent Load = Actual Load x Service Factor

Mechanical ratings and service factor Fm

Mechanical ratings measure capacity in terms of life and/or strength, assuming 10 hr/day continuous running under uniform load conditions.

Catalogue ratings allow 100% overload at starting, braking or momentarily during operation up to 10 hours per day.

The unit selected must therefore have a catalogue rating at least equal to half maximum overload.

Mechanical Service Factor Fm (Table 1) is used to modify the actual load according to daily operating time, and type of loading.

Load characteristics for a wide range of applications are detailed in Table 3 opposite, which are used in deciding the appropriate Service Factor Fm from Table 1.

If overloads can be calculated, or accurately assessed, actual loads should be used instead of Fm.

For units subjected to frequent stop/starts overloads in excess of 10 times/day multiply factor Fm x Factor Fs (table 2).

Table 1. Mechanical Service Factor (Fm)

Prime Mover	Duration of service hrs Per day	Load classification- driven machine		
		Uniform mass acceleration factor < 0.2	Moderate mass acceleration factor < 0.3	Heavy acceleration factor < 10
Electric Motor, Steam Turbine, or Hydraulic Motor	< 3	0.80	1.00	1.50
	3 - 10	1.00	1.25	1.75
	> 10	1.25	1.50	2.00
Multi-cylinder internal combustion engine	< 3	1.00	1.25	1.75
	3 - 10	1.25	1.50	2.00
	> 10	1.50	1.75	2.25
single cylinder internal combustion engine	< 3	1.25	1.50	2.00
	3 - 10	1.50	1.75	2.25
	> 10	1.75	2.00	2.50

Mass acceleration factor = $\frac{\text{all external moments of inertia} *}{\text{moment of inertia of driving motor}}$

* calculated with reference to the motor speed

Table 2. Number of Starts Factor (Fs)

Starts/ stops per hour	< 1	5	10	40	60	> 200
Factor FS	1.00	1.03	1.06	1.10	1.15	1.20

Note: (1) Intermediate values are obtained by linear interpolation

Thermal Rating (For In-line Reducers)

The Thermal Rating is the gearboxes ability to dissipate heat. If exceeded, may cause the lubricant to break down resulting in premature gear failure. A thermal check should be made in accordance with the Thermal Rating Procedure

S SERIES

LOAD CLASSIFICATION BY APPLICATION

Load Classifications - U =Uniform Load M =Moderate Shock Load H =Heavy Shock Load † =Consult our Engineers

Agitators		Elevators		Machine Tools		Pumps	
Pure liquids	U	Bucket - Uniform load	U	Bending roll	M	Centrifugal proportioning	U
Liquids and solids	M	Bucket - Heavy load	M	Punch press	H	Proportioning	M
Liquids variable density	M	Bucket - Continuous	U	Notching press	H	Reciprocating	
		Centrifugal discharge	U	Plate planer	H	Single acting 3+ cylinders	M
Blowers		Escalators	U	Other machine tools		Double acting 2+ cylinders	M
Centrifugal	U	Freight	M	Main drive	M	Single acting 1 & 2 cylinders	†
Lobe	M	Gravity discharge	U	Aux drive	U	Double acting 1 cylinder	†
Vane	U	Passenger lifts	†			Rotary- gear type	U
				Metal mills		Rotary- lobe type/ vane	U
Brewing & distilling		Fans		Carriage/main drive	M		
Bottling machinery	M	Centrifugal	U	Draw bench	M	Sand muller	M
Brew Kettles	M	Cooling towers		Dryer	M		
Cookers	M	Induced draft	†	Flattening machinery	M	Sewage treatment	
Mash tubs	M	Forced draft	†	Pinch drive	M	Bar screen	U
Scale hopper	M	Fan - Large diameter induced draft	M	Reversing slitters	M	Chemical feeder	U
		Fan - Light, small diameter	M	Scrubber rolls	M	Collector	U
				Table conveyors		Dewatering screw	M
Can filling machinery	M	Feeders		Group drives	H	Mixers	M
		Apron	M	Individual drives	H	Scum breaker	M
Crane knife	M	Belt	U	Table conveyors- reversing	H	Thickness	M
		Disc	U	Wire draw	M	Vacuum filters	M
Car dumper	M	Reciprocating	H	Wire roll	M		
		Screw	M			Screens	
Car puller	M			Mills		Air washing	U
		Food industry		Cement kiln	H	Rotary, stone or gravel	M
Clarifier	U	Cereal cooker	U	Dryer, Cooler	H	Traveling water intake	U
		Dough mixer	M	Kiln (other)	H		
Classifier	M	Meat grinder	M	Rod plain	H		
		Meat slicer	M	Rod wedge bar	H	Slab pushers	M
				Rotary/ Ball	H		
Clay wokring machinery		Generators - not welding	U	Tumbling barrel	H	Slewing	H
Brick press	H						
Briquette machine	H	Hammer mills	H	Mixers		Steering gear	†
Clay working machinery	M			Concrete	M		
Plug mill	M			Cons density	U	Stokers	U
		Hoists		Variable density	M		
Compressors		Heavy duty	H			Sugar industry	
Centrifugal	U	Medium duty	M	Oil industry		Can knife	M
Lobe	M	Skip hoist	M	Chiller's	M	Crusher	M
Reciprocating				Oil well pump	M	Mills	M
Multi cylinder	M	Laundry		Filter press	M		
Single cylinder	H	Tumbler	M	Rotary kiln	M	Textile industry	
		Washer	M			Batchers	
Conveyors- Light duty uniform load		Line shafts		Paper industry		Calenders	M
Apron	U	Heavy duty	M	Agitator (mixer)	M	Cards	M
Assembly	U	Light duty	U	Barker (hydraulic)	M	Dry cans	M
Belt	U			Barker (mechanical)	H	Dryers	M
Bucket	U	Lumber industry		Barking drum	H	Dyeing machinery	M
Chain	U	Barkers	M	Beater & Pulper	M	Knitting machinery	M
Flight	U	Burner conveyor	H	Bleacher	U	Looms	M
Oven	U	Chain/ Drag saw	H	Calednders	M	Mangles	M
Screw	U	Chain transfer	H	Calenders- super	H	Nappers	M
		Chain way transfer	H	Converting machine	M	Pads	M
Conveyors - Heavy duty uniform load		De- barking drum	H	Conveyors	U	Range drive	M
Apron	M	Edger feed	M	Couch	M	Slashers	M
Assembly	M	Gang feed	M	Cutters - plates	H	Soapers	M
Belt	M	Green chain	M	Cylinders	M	Spinners	M
Bucket	M	Live roll	H	Dryers	M	Tenter frame	M
Chain	M	Log deck	H	Felt stretcher	M	Washers	M
Flight	M	Log haul	H	Felt whipper	H	Winders	M
Live roll	†	Log turning	H	Jordans	M		
Oven	M	Log conveyoyr	H	Log haul	H	Windlass	†
Reciprocating	M	Of bearing roll	M	Machine real	M		
Screw	M	Planer feed chaines	M	Presses	M		
Shaker	M	Planer hoist	M	Stock chest	M		
		Re-saw conveyoyr	M	Suction roll	M		
Cranes	†	Roll cases	H	Washers & thickeners	M		
		Slab conveyoyr	H	Winders	M		
Crusher		Sorting table - triple hoist	M				
Ore	H	Triple hoist - Drive /conveyoyr	M	Printing presses	†		
Stone	H	Transfer conveyoyr	M				
Sugar	H	Transfer roll	M	Pullers			
		Tray drive	M	Barge haul	H		
Dredger	M	Trimmer feed	M				
Cable reals	M	Waster conveyoyr	M				
Conveyors	M	Small waste conveyoyr (belt)	U				
Cutter head drive	H	Small waste conveyoyr (chain)	U				
Pumps	M						
Screen drive	H						
Stackers	M						
Winches	M						

S SERIES SELECTION PROCEDURE FOR MOTORISED UNITS

EXAMPLE APPLICATION DETAILS

Absorbed power of driven machine = 0.7 kW
 Output speed of gearbox or Input speed of machine = 68 rev/min
 Application = Uniformly loaded belt conveyor
 Duration of service (hours per day) = 24hrs
 Mounting position = 1
 Ambient temperature = 20°C
 Running time (%) = 100%

Note!
 If you select a S Series Reducer for use without TEFC motor, A thermal check must be made.

1 DETERMINE MECHANICAL SERVICE FACTOR (Fm)

Refer to Load Classification by Application, table 3, page 6

Application = Uniformly loaded belt conveyor

Conveyors-uniformly loaded or fed

apron	U	U = Uniform load
assembly	U	
belt	U	
bucket	U	
chain	U	

Refer to mechanical service factor (Fm)

Duration of service (hours per day) = 24hrs

Prime mover	Duration of services per day	Load classification	
		Uniform	Moderate
Electric motor, steam turbine or hydraulic motor	< 3	0.80	1.00
	3 - 10	1.00	1.25
	> 10	1.25	1.50

Therefore mechanical service factor (Fm) = 1.25

If the unit is subject to frequent start/stops Fm must be multiplied by factor Fs

2 DETERMINE REQUIRED OUTPUT TORQUE AT GEARBOX OUTPUT SHAFT

Absorbed output torque = $\frac{\text{Absorbed power} \times 9550}{\text{Gearbox output speed}}$

$$\frac{0.7 \times 9550}{68} = 98 \text{ Nm}$$

3 SELECT GEARED MOTOR

Refer to selection table one motor size larger than absorbed power.

Absorbed power = 0.7 kW, therefore refer to 0.75 kW selection table.

Always select from 4 POLE selection table in the first instance as this offers a more economical solution.

Required output speed of gearbox = 68 rev/min

0.75 kW 4 POLE	N2 R/MIN	i	M2 Nm	Fm	N	UNIT DESIGNATION Column Entry <input type="text" value="1"/> Through <input type="text" value="20"/> Spaces to be filled when entering order	Kg Weight of Base Mount Unit	Motor Frame Size
	Output Speed	Ratio	Output Torque	Service Factor	Overhung Load			
	165	8.59	36	2.24	2841	S 0 3 2 1 8 . 0 _ M _ _ _ . 7 5 A - -	19.5	80A
	122	11.61	48	1.81	2837	1 1 .		
	107	13.20	54	1.65	2832	1 2 .		
	95	14.95	62	1.51	2832	1 4 .		
	86	16.36	60	1.44	2827	1 6 .		
	74	19.12	78	1.27	2821	1 8 .		
	69	20.61	84	1.2	2821	2 0 .		
	64	22.11	80	1.18	2821	2 2 .		
	56	25.14	90	1.08	2810	2 5 .		
	50	28.48	101	1	2810	2 8 .		

Go to point 4

S SERIES

SELECTION PROCEDURE FOR MOTORISED UNITS

4 CHECK OUTPUT TORQUE

Output torque (M2) of selected unit must be equal or more than required output torque at gearbox outputshaft.

Required output torque at gearbox outputshaft = 98 Nm.

0.75 kW 4 POLE	N2 R/MIN	i	M2 Nm	Fm	N	UNIT DESIGNATION	Kg	
	Output SPEED	Ratio	Output Torque	Service Factor	Overhung Load	Column Entry <input type="text" value="1"/> Through <input type="text" value="20"/> Spaces to be filled when entering order	Weight of Base Mount Unit	Motor Frame Size
	74	19.12	78	1.27	2821	S 0 3 2 1 1 8 . _ M _ _ _ . 7 5 A _ _	19.5	80A
	69	20.61	84	1.2	2821	2 0 .		
	64	22.11	80	1.18	2821	2 2 .		

However the output torque is only 84 against the requirement of 98 Nm, hence a unit fitted with a 1.1 kW motor is required

1.1 kW 4 POLE	N2 R/MIN	i	M2 Nm	Fm	N	UNIT DESIGNATION	Kg	
	Output SPEED	Ratio	Output Torque	Service Factor	Overhung Load	Column Entry <input type="text" value="1"/> Through <input type="text" value="20"/> Spaces to be filled when entering order	Weight of Base Mount Unit	Motor Frame Size
	74	19.12	115	0.86	2800	S 0 3 2 1 1 8 . _ M _ _ _ . 1 - 1 A _ _	24.5	90S
	68	20.61	123	0.82	2800	2 0 .		
	64	22.11	117	1.8	2800	2 2 .		

Selected unit's output torque (M2) = 123 Nm, therefore the torque from a 1.1 kW motor is acceptable.

5 CHECK SERVICE FACTOR

Service factor (Fm) of selected unit must be equal or more than required service factor.

Required service factor of gearbox = 1.25

1.1 kW 4 POLE	N2 R/MIN	i	M2 Nm	Fm	N	UNIT DESIGNATION	Kg	
	Output SPEED	Ratio	Output Torque	Service Factor	Overhung Load	Column Entry <input type="text" value="1"/> Through <input type="text" value="20"/> Spaces to be filled when entering order	Weight of Base Mount Unit	Motor Frame Size
	74	19.12	115	0.86	2800	S 0 3 2 1 1 8 . _ M _ _ _ . 1 - 1 A _ _	24.5	90S
	68	20.61	123	0.82	2800	2 0 .		
	64	22.11	117	0.8	2800	2 2 .		
	86	16.36	91	1.57	5275	S 0 4 2 1 1 6 . 0 _ M _ _ _ . 1 - 1 A _ _	26.5	90S
	74	19.12	117	1.43	5275	S 0 4 2 1 1 8 . 0		
	68	20.61	125	1.36	5275	S 0 4 2 1 2 0 . 0		
	64	22.11	121	1.28	5275	S 0 4 2 1 2 2 . 0		

The service factor (Fm) is only 0.82, therefore this unit is not acceptable and a larger S0421 unit must be selected with a service factor (Fm) of 1.36

5 CHECK OVERHUNG LOADS

If sprocket, gear, etc is mounted on the outputshaft then refer to Overhung Loads Procedure, and compare with allowable overhung load (N) of selected unit

Allowable overhung load (N) must be equal or more than calculated overhung load (P)

1.1 kW 4 POLE	N2 R/MIN	i	M2 Nm	Fm	N	UNIT DESIGNATION	Kg	
	Output Speed	Ratio	Output Torque	Service Factor	Overhung Load	Column Entry <input type="text" value="1"/> Through <input type="text" value="20"/> Spaces to be filled when entering order	Weight of Base Mount Unit	Motor Frame Size
	164	8.59	54	2.51	5286	S 0 4 2 1 8 . 0 _ M _ _ _ . 1 - 1 A _ _	24.5	90S
	121	11.61	72	2.04	5279	1 1 .		
	107	13.20	82	1.87	5280	1 2 .		
	94	14.95	92	1.71	5275	1 4 .		
	86	16.36	91	1.57	5275	1 6 .		
	74	19.12	117	1.43	5275	1 8 .		
	68	20.61	125	1.36	5275	2 0 .		
	64	22.11	121	1.28	5275	2 2 .		

NOTE: If any of the following conditions occur then consult our Application Engineers:-

a) Inertia of the Driven Machine (Referred to motor speed) >10
Inertia of Gear Unit plus the Motor

b) Ambient temperature is above 40°C

S SERIES

OUTPUT OPTIONS

OUTPUTSHAFT OPTIONS. COLUMN 11 ENTRY

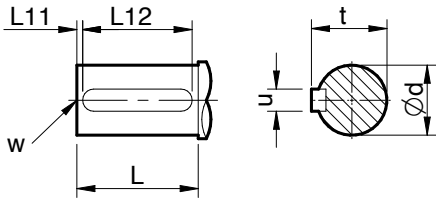

* Inch shafts have open ended keyways, therefore no 'L11' dimension is required

Column 11 Entry

Standard Single Extension C on Left E on Right

Standard Double Extension D

Std Heavy Duty Single Extension (Size S06) J

Std Heavy Duty Double Extension (Size S06) K

Inch Single Extension N on Left B on Right

Inch Double Extension P

Inch Heavy Duty Single Extension (Size S06) L

Size	Type of Output Shaft	Column 11 Entry	Dimensions in mm (Inch shaft in inches)						
			ød	L	L11	L12	t	u	w
S03	Metric - Standard	C, E, D	20.015 / 20.002	35	3	31.2	2.5	6	M6 x 1.0 x 16
	Inch	N, B, P	0.7500" / 0.7495"	1.38"	*	1.28"	0.83"	0.19"	1/4 UNF x 0.63"
S04	Metric - Standard	C, E, D	25.015 / 25.002	46	3	42	28	8	M10 x 1.5 x 22
	Inch	N, B, P	1.0000" / 0.9995"	1.81"	*	1.69"	1.10"	0.25"	1/4 UNF x 0.63"
S05	Metric - Standard	C, E, D	30.015 / 30.002	60	3	53	33	8	M10 x 1.5 x 22
	Inch	N, B, P	1.2500" / 1.2494"	2.36"	*	2.125"	1.36"	0.25"	3/8 UNF x 0.87"
S06	Metric - Standard	C, E, D	35.018 / 35.002	63	3	55	38	10	M12 x 1.75 x 22
	Metric - Heavy Duty	J, K	45.018 / 45.002	98	5	80	48.5	14	M16 x 2.0 x 36
	Inch	N, B, P	1.3750" / 1.3744"	2.48"	*	2.34"	1.51"	0.313"	1/2 UNF x 1.125"
	Inch - Heavy Duty	L	1.7500" / 1.7494"	3.86"	*	3.75"	1.92"	0.375"	5/8 UNF x 1.44"
S07	Metric - Standard	C, E, D	45.018 / 45.002	76	3	70	48.5	14	M16 x 2.0 x 36
	Inch	N, B, P	1.7500" / 1.7494"	2.99"	*	2.625"	1.917"	0.375"	5/8 UNF x 1.44"
S08	Metric - Standard	C, E, D	60.030 / 60.011	120	3	110	64	18	M20 x 2.5 x 42
	Inch	N, B	2.3750" / 2.3744"	4.72"	*	4.125"	2.646"	0.625"	3/4 UNF x 1.75"
	Inch - Double Ext	P	2.3125" / 2.3115"	4.72"	*	4.125"	2.582"	0.625"	3/4 UNF x 1.75"
S09	Metric - Standard	C, E, D	70.030 / 70.011	135	3	125	74.5	20	M20 x 2.5 x 42
	Inch	N, B	2.8750" / 2.8740"	5.12"	*	4.5"	3.20"	0.75"	3/4 UNF x 1.75"
	Inch - Double Ext	P	2.6875" / 2.6865"	5.12"	*	4.5"	2.963"	0.625"	3/4 UNF x 1.75"
S10	Metric - Standard	C, E, D	90.035 / 90.013	170	3	160	95	25	M24 x 3.0 x 50
	Inch	N, B	3.6250" / 3.6240"	6.69"	*	5.875"	4.009"	0.875"	1 UNF x 2.25"
	Inch - Double Ext	P	3.1875" / 3.1865"	6.69"	*	5.875"	3.518"	0.750"	1 UNF x 2.25"

S SERIES

OUTPUTBORE OPTIONS

OUTPUT BORE OPTIONS, COLUMN 11 ENTRY

Column 11 Entry

Metric Hollow Shaft



Inch Hollow Shaft



Metric Hollow Shaft with
reduced bore diameter

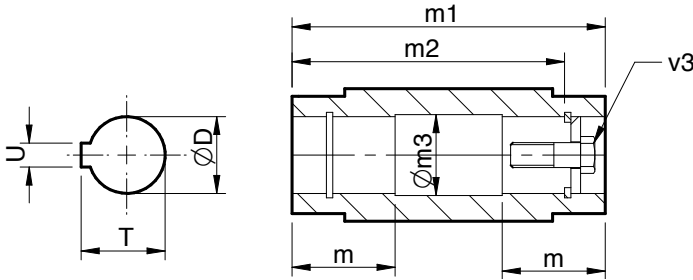

Size	Type of Bore	Column 11 Entry	Dimensions in mm (Inch shaft in inches)							
			ØD	m	m1	m2	Øm3	T	U	v3
S03	Standard	H	20.021/20.000	52	124	104	20.2	22.9	6	M6 x 1.0 x 40
	Inch	A	0.7508"/0.7500"	2.05"	4.88"	4.13"	0.76"	0.84"	0.188"	1/4" UNF x 1 1/2"
S04	Standard	H	30.021/30.000	54	130	122	30.2	33.5	8	M10 x 1.5 x 50
	Reduced Dia	Z	25.021/25.000	54	130	125	25.2	28.5	8	M10 x 1.5 x 50
	Inch	A	1.2510"/1.2500"	2.13"	5.12"	4.81"	1.26"	1.37"	0.25"	3/8 UNF x 2"
S05	Standard	H	35.025/35.000	56	140	127	35.3	38.5	10	M12 x 1.75 x 55
	Reduced Dia	Z	30.021/30.000	56	140	127	30.3	33.5	8	M10 x 1.5 x 45
	Inch	A	1.3760"/1.3750"	2.20"	5.52"	5.00"	1.39"	1.53"	0.313"	1/2" UNF x 2"
S06	Standard	H	45.025/45.000	70	180	156	45.3	49	14	M16 x 2.0 x 70
	Reduced Dia	Z	40.025/40.000	70	180	156	40.3	43.5	12	M16 x 2.0 x 70
	Inch	A	1.5010"/1.5000"	2.76"	7.08"	6.14"	1.51"	1.67"	0.375"	5/8" UNF x 2 3/4"
S07	Standard	H	60.030/60.000	79	218	188	60.5	64.6	18	M20 x 2.5 x 80
	Reduced Dia	Z	50.030/50.000	79	218	191	50.5	54	14	M16 x 2.0, x 70
	Inch	A	2.0010"/2.0000"	3.11"	8.58"	7.41"	2.02"	2.23"	0.50"	5/8" UNF x 3"
S08	Standard	H	70.030/70.000	90	250	220	70.5	75.1	20	M20 x 2.5 x 80
	Reduced Dia	Z	60.030/60.000	90	250	220	60.5	64.6	18	M20 x 2.5 x 80
	Inch	A	2.3760"/2.3750"	3.54"	9.84"	8.68"	2.40"	2.66"	0.625"	3/4" UNF x 3"
S09	Standard	H	90.035/90.000	107.5	300	265	90.5	95.6	25	M24 x 3.0 x 110
	Reduced Dia	Z	70.030/70.000	107.5	300	270	70.5	75.1	20	M20 x 2.5, x100
	Inch	A	2.7510"/2.7500"	4.23"	11.82"	10.65"	2.76"	3.04"	0.625"	3/4" UNF x 4 1/4"
S10	Standard	H	100.035/100.000	132.5	350	313	100.5	106.6	28	M24 x 3.0 x 110
	Reduced Dia	Z	80.030/80.000	132.5	350	313	80.5	85.6	22	M20 x 2.5 x 100
	Inch	A	3.2510"/3.2500"	5.22"	13.78"	12.32"	3.26"	3.59"	0.75"	1" UNF x 4 1/4"

S SERIES MOTOR ADAPTERS IEC AND NEMA

Double Reduction Units

Compact Motor - Column 12 Entry - D

Power	S0321		S0421		S0521		S0621		S0721		S0821	
	8.0 - 28. 36. - 40.	32. 45. - 250	8.0 - 28. 36. - 40.	32. 45. - 250	8.0 - 40. 56. - 63.	45. - 50. 71. - 250	8.0 - 28. 36. - 40.	32. 45. - 250	8.0 - 28. 36. - 40.	32. 45. - 250	8.0 - 40. 56. - 63.	45. - 50. 71. - 250
0.25 kW	•	•	•	•	•	•	•	•	•	•	•	•
0.37 kW	•	•	•	•	•	•	•	•	•	•	•	•
0.55 kW	•	•	•	•	•	•	•	•	•	•	•	•
0.75 kW	•	•	•	•	•	•	•	•	•	•	•	•
1.1 kW	•	•	•	•	•	•	•	•	•	•	•	•
1.5 kW	•	•	•	•	•	•	•	•	•	•	•	•
2.2 kW	•	•	•	•	•	•	•	•	•	•	•	•
3.0 kW	•	•	•	•	•	•	•	•	•	•	•	•
4.0 kW	•	•	•	•	•	•	•	•	•	•	•	•
5.5 kW	•	•	•	•	•	•	•	•	•	•	•	•
7.5 kW	•	•	•	•	•	•	•	•	•	•	•	•

Standard Motor IEC Flanges B14 - Column 12 Entry

Motor	S0321		S0421		S0521		S0621		S0721	
	8.0 - 28. 36. - 40.	32. 45. - 250	8.0 - 28. 36. - 40.	32. 45. - 250	8.0 - 40. 56. - 63.	45. - 50. 71. - 250	8.0 - 28. 36. - 40.	32. 45. - 250	8.0 - 28. 36. - 40.	32. 45. - 250
71	H	H	H	H	-	H	-	-	-	-
80	B	K	B	K	B	K	-	G	-	G
90	D	R	D	R	D	R	Z	J	-	J
100	E	S	E	S	E	S	B	L	B	L
112	E	S	E	S	E	S	B	L	B	L
132	-	-	-	-	-	-	-	-	D	N

Standard Motor IEC Flanges B5 - Column 12 Entry

Motor	S0321		S0421		S0521		S0621		S0721		S0821		S0921		S1021	
	8.0 - 28. 36. - 40.	32. 45. - 250	8.0 - 28. 36. - 40.	32. 45. - 250	8.0 - 40. 56. - 63.	45. - 50. 71. - 250	8.0 - 28. 36. - 40.	32. 45. - 250	8.0 - 28. 36. - 40.	32. 45. - 250	8.0 - 40. 56. - 63.	45. - 50. 71. - 250	8.0 - 40. 56. - 63.	45. - 50. 71. - 250	8.0 - 40. 56. - 63.	45. - 50. 71. - 250
63	F	F	F	F	-	F	-	V	-	-	-	-	-	-	-	-
71	G	G	G	G	-	G	-	D	-	-	-	-	-	-	-	-
80	A	J	A	J	A	J	W	F	-	F	-	D	-	E	-	-
90	C	Q	C	Q	C	Q	Y	H	-	H	-	F	-	F	-	-
100	-	-	-	-	-	-	A	K	A	K	A	F	-	G	-	E
112	-	-	-	-	-	-	A	K	A	K	A	F	-	G	-	E
132	-	-	-	-	-	-	N	P	C	M	B	G	-	H	-	F
160	-	-	-	-	-	-	-	-	E	P	C	H	A	J	A	G
180	-	-	-	-	-	-	-	-	-	-	-	-	B	K	B	H
200	-	-	-	-	-	-	-	-	-	-	-	-	C	L	C	J
225	-	-	-	-	-	-	-	-	-	-	-	-	D	M	D	K

NEMA Motor C Face - Column 12 Entry

Motor	S0321		S0421		S0521		S0621		S0721		S0821		S0921		S1021	
	8.0 - 28. 36. - 40.	32. 45. - 250	8.0 - 28. 36. - 40.	32. 45. - 250	8.0 - 40. 56. - 63.	45. - 50. 71. - 250	8.0 - 28. 36. - 40.	32. 45. - 250	8.0 - 28. 36. - 40.	32. 45. - 250	8.0 - 40. 56. - 63.	45. - 50. 71. - 250	8.0 - 40. 56. - 63.	45. - 50. 71. - 250	8.0 - 40. 56. - 63.	45. - 50. 71. - 250
56c	T	U	T	U	T	U	-	Q	-	Q	-	M	-	-	-	-
143/145TC	V	W	V	W	V	W	-	R	-	R	-	N	-	-	-	-
182/184TC	X	-	X	-	X	-	S	T	S	T	J	P	-	S	-	P
213/215TC	-	-	-	-	-	-	U	-	U	V	K	Q	-	T	-	Q
254/256TC	-	-	-	-	-	-	-	-	W	-	L	U	P	U	L	R
284/286TC	-	-	-	-	-	-	-	-	-	-	-	Q	V	M	S	S
324/326TC	-	-	-	-	-	-	-	-	-	-	-	R	W	N	T	T

S SERIES MOTOR ADAPTERS IEC AND NEMA

Triple Reduction Units

Compact Motor - Column 12 Entry - D

Power	S0331		S0431		S0531		S0631		S0731	
	132 - 150	100 - 118 160 - 900	132 - 150	100 - 118 160 - 900	132 - 150	100 - 118 160 - 900	100 - 150 200 - 225	160 - 180 265 - 900	132 - 150	100 - 118 160 - 900
0.25 kW	•	•	•	•	•	•	-	•	-	-
0.37 kW	•	•	•	•	•	•	-	•	-	-
0.55 kW	•	•	•	•	•	•	•	•	-	•
0.75 kW	•	•	•	•	•	•	•	•	-	•
1.1 kW	•	-	•	-	•	-	•	-	•	•
1.5 kW	•	-	•	-	•	-	•	-	•	•
2.2 kW	-	-	-	-	-	-	-	-	•	•
3.0 kW	-	-	-	-	-	-	-	-	•	•
4.0 kW	-	-	-	-	-	-	-	-	•	-
5.5 kW	-	-	-	-	-	-	-	-	•	-
7.5 kW	-	-	-	-	-	-	-	-	-	-

Standard Motor IEC Flanges B14 - Column 12 Entry

Motor	S0331		S0431		S0531		S0631		S0731	
	132 - 150	100 - 118 160 - 900	132 - 150	100 - 118 160 - 900	132 - 150	100 - 118 160 - 900	100 - 150 200 - 225	160 - 180 265 - 900	132 - 150	100 - 118 160 - 900
71	H	H	H	H	H	H	-	H	-	-
80	B	K	B	K	B	K	B	K	-	G
90	D	R	D	R	D	R	D	R	Z	J
100	E	S	E	S	E	S	E	S	B	L
112	-	-	-	-	-	-	-	-	B	L

Standard Motor IEC Flanges B5 - Column 12 Entry

Motor	S0331		S0431		S0531		S0631		S0731	
	132 - 150	100 - 118 160 - 900	132 - 150	100 - 118 160 - 900	132 - 150	100 - 118 160 - 900	100 - 150 200 - 225	160 - 180 265 - 900	132 - 150	100 - 118 160 - 900
63	F	F	F	F	F	F	-	F	-	V
71	G	G	G	G	G	G	-	G	-	D
80	A	J	A	J	A	J	A	J	W	F
90	C	Q	C	Q	C	Q	C	Q	Y	H
100	-	-	-	-	-	-	-	-	A	K
112	-	-	-	-	-	-	-	-	A	K
132	-	-	-	-	-	-	-	-	N	P

NEMA Motor C Face - Column 12 Entry

Motor	S0331		S0431		S0531		S0631		S0731	
	132 - 150	100 - 118 160 - 900	132 - 150	100 - 118 160 - 900	132 - 150	100 - 118 160 - 900	100 - 150 200 - 225	160 - 180 265 - 900	132 - 150	100 - 118 160 - 900
56c	T	U	T	U	T	U	T	U	-	Q
143/145TC	V	W	V	W	V	W	V	W	-	R
182/184TC	X	-	X	-	X	-	X	-	S	T
213/215TC	-	-	-	-	-	-	-	-	U	-

S SERIES MOTOR ADAPTERS IEC AND NEMA

Quadruple Reduction Units

Compact Motor - Column 12 Entry - D

Power	S0341	S0441	S0541	S0641	S0741	S0841		S0941		S1041	
	All Ratios	All Ratios	All Ratios	All Ratios	All Ratios	500	560 +	500	560 +	450	560 +
0.25 kW	•	•	•	•	•	-	-	-	-	-	-
0.37 kW	•	•	•	•	•	-	-	-	-	-	-
0.55 kW	•	•	•	•	•	-	•	-	•	-	-
0.75 kW	•	•	•	•	•	-	•	-	•	-	-
1.1 kW	-	-	-	-	-	•	•	•	•	-	•
1.5 kW	-	-	-	-	-	•	•	•	•	-	•
2.2 kW	-	-	-	-	-	•	•	•	•	-	•
3.0 kW	-	-	-	-	-	•	•	•	•	-	•
4.0 kW	-	-	-	-	-	•	-	•	-	-	•
5.5 kW	-	-	-	-	-	•	-	•	-	-	•
7.5 kW	-	-	-	-	-	-	-	-	-	-	•

Standard Motor IEC Flanges B14 - Column 12 Entry

Motor	S0341	S0441	S0541	S0641	S0741	S0841		S0941		S1041	
	All Ratios	All Ratios	All Ratios	All Ratios	All Ratios	500	560 +	500	560 +	450	560 +
71	H	H	H	H	H	-	-	-	-	-	-
80	K	K	K	K	K	-	G	-	G	-	G
90	R	R	R	R	R	Z	J	Z	J	-	J
100	S	S	S	S	S	B	L	B	L	B	L
112	-	-	-	-	-	B	L	B	L	B	L
132	-	-	-	-	-	-	-	-	-	D	N

Standard Motor IEC Flanges B5 - Column 12 Entry

Motor	S0341	S0441	S0541	S0641	S0741	S0841		S0941		S1041	
	All Ratios	All Ratios	All Ratios	All Ratios	All Ratios	500	560 +	500	560 +	450	560+
63	F	F	F	F	F	-	V	-	V	-	-
71	G	G	G	G	G	-	D	-	D	-	-
80	J	J	J	J	J	W	F	W	F	-	F
90	Q	Q	Q	Q	Q	Y	H	Y	H	-	H
100	-	-	-	-	-	A	K	A	K	A	K
112	-	-	-	-	-	A	K	A	K	K	K
132	-	-	-	-	-	N	P	N	P	C	M
160	-	-	-	-	-	-	-	-	-	E	-

NEMA Motor C Face - Column 12 Entry

Motor	S0341	S0441	S0541	S0641	S0741	S0841		S0941		S1041	
	All Ratios	All Ratios	All Ratios	All Ratios	All Ratios	500	560 +	500	560 +	450	560 +
56c	U	U	U	U	U	-	Q	-	Q	-	Q
143/145TC	W	W	W	W	W	-	R	-	R	-	R
182/184TC	-	-	-	-	-	S	T	S	T	S	T
213/215TC	-	-	-	-	-	U	-	U	-	U	V

S SERIES

LUBRICATION

Lubricant and Quantity

Unit sizes S03, 04, 05 and 06 are factory filled with a grade 6G lubricant.

Unit sizes S07, 08, 09 and 10 will be despatched without oil.

The oil grade is stamped on the name plate and the oil level should be established by filling until the oil escapes via the level plug,

The grade and level are determined from the operating speed of the gear unit and the ambient temperature range, which if not given when ordering will be assumed to be 1450 rev / min input and ambient temperature range 0 to 35°C. Oil grades and oil level should always be checked before installation, Consult the Installation and Maintenance instructions provided with the gear unit.

To determine the oil grade refer to table 1, and then refer to the Installation and Maintenance instructions to select an approved lubricant

To determine the oil capacity refer to appropriate table 2 or 3. Oil capacities are only approximate and units should be filled until oil escapes from the level plug holes. Do not overfill as excess will cause overheating and leakage.

Always fill with correct lubricant as marked on the nameplate. Never mix lubricant grades.

See Installation and Maintenance instructions for for lists of approved lubricants within the grades.

If not stated with the order these are the operating conditions that will be assumed

Note: Catalogue ratings are based on Polyglycol Synthetic lubricant
Use with mineral or alternative lubricants may require a derate, please contact our Application Engineers.

Table 1 S Series oil grades

Gear unit details			Ambient temperature range		
Type	Gear unit details	Input Speed (Rev/min)	-30°C - 20°C	0°C - 35°C	20°C - 50°C
Doubles	Ratio 8 - 18	0 - 750	6G	6G	8G
		0>750 - 2000	5G	6G	7G
		>2000 - 3000	4G	6G	6G
	20 - 36	0 - 2000	6G	6G	8G
		>2000 - 3000	5G	6G	7G
		40 - 250	0 - 3000	6G	6G
Quadruples	< - 2800	0 - 750	6G	7G	9G
		>750 - 3000	6G	6G	8G
	3200 - 16000	0 - 3000	6G	7G	9G

* For other ambient temperatures please refer to our Application Engineers.

Table 2 lubricant quantity (Litres) (double reduction and final stage quadruple reduction)

Double, Triple & Final stage Quadruple Reduction															
Size		S0321	S0331	S0421	S0431	S0521	S0531	S0621	S0631	S0721	S0731	S0821	S0921	S1021	
Mounting position	1	Level 1 *	0.3	0.4	0.4	0.5	0.7	0.9	1.5	2.1	4.5	4.8	7.1	17	28
		Level 2 *									3.0	3.8	5.9	11	17
	2		0.5	0.8	0.7	0.9	1.0	1.4	2.3	2.5	3.5	3.7	6.2	12	21
			0.5	0.8	0.7	0.9	1.0	1.4	2.2	2.5	3.5	3.7	6.2	12	21
	4	Level 1 *	0.7	1.2	1.0	1.5	1.4	2.1	3.1	4.0	5.1	5.9	9.5	17	26
		Level 2 *									3.0	3.6	4.8	8.3	14
	5		0.6	1.0	0.9	1.3	1.4	2.0	3.0	4.6	5.6	6.6	9.6	18	31
			0.7	1.2	1.0	1.5	1.4	1.9	3.2	4.0	7.4	9.2	12	25	42
	6	Level 1 *	0.7	1.2	1.0	1.5	1.4	1.9	3.2	4.0	5.1	5.9	9.5	17	28
		Level 2 *									5.1	6.9	9.5	17	28

* Use Level 1 for output speeds lower than 100 rpm * Use Level 2 for output speeds of 100 rpm and higher.

Table 3 lubricant quantity (Litres) (primary stage quadruple reduction)

Primary stage quadruple reduction									
Size	S0341	S0441	S0541	S0641	S0741	S0841	S0941	S1041	
Secondary unit (Lubricant quantity see table 2)	S0321	S0421	S0521	S0621	S0721	S0821	S0921	S1021	
Primary unit	R0122	R0122	R0122	R0322	R0322	R0522	R0522	R0722	
Primary Quantity (unit lubricant)	1 to 4	0.5	0.5	0.5	0.8	0.8	1.5	1.5	2.6
	5 & 6	1.0	1.0	1.0	1.4	1.4	2.6	2.6	4.7

• Unit filled with Grade 6E lubricant suitable for all ambient temperatures between 0°C to 35°C and are 'lubricated for life'

S SERIES

MOUNTING POSITIONS

Column 13 Entry

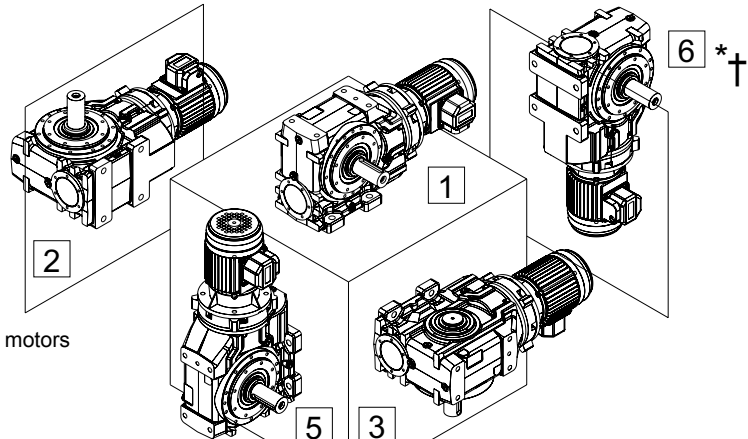

Base Mounted Units

* Mounting Position 6 is not recommended for geared motors
- Consult Application Engineering

† Gear Units for use in mounting positions 5 and 6 should only be selected with overall ratios greater or equal to those shown in table below

Size	Input speed (RPM)			
	1000	1500	1800	>1800
S03-S08	All	All	All	Consult application engineering
S09	18:1	18:1	25:1	
S10	18:1	40:1	63:1	

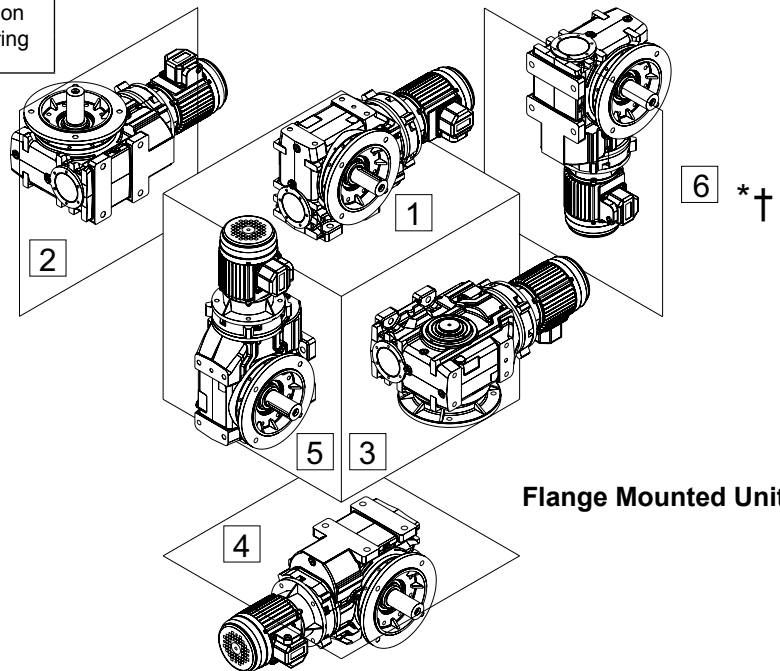

Flange Mounted Units

Mounting Positions- Shown as Motorised - Applies also for Reducers

COLUMN 14 ENTRY

All motors

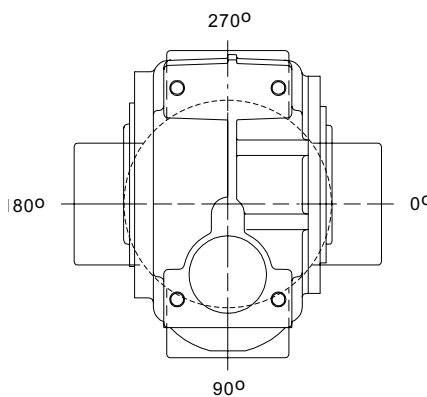

Column 14 entry	Terminal box position
A	0°
B	90°
C	180°
D	270°
-	Reducer or no motor fitted

S SERIES

UNIT HANDINGS

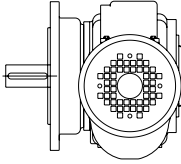
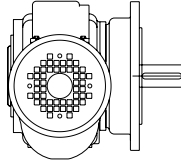
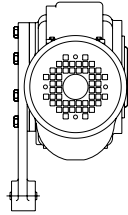
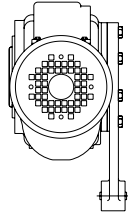
Column 9 entry	Left	Right
Std unit with foutput flange	F 	H 
Std unit with Torque bracket	T 	Q 

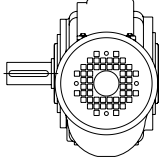
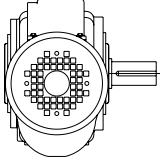
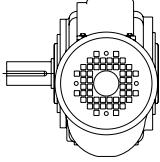
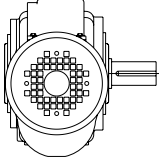
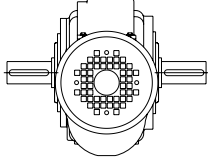
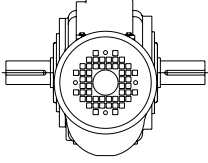
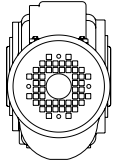
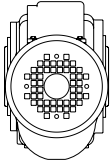
Column entry 11	Metric		Inch	
	Left	Right	Left	Right
Single output shaft	C 	E 	N 	B 
Double output shaft	D 		P 	
Hollow shaft	H 		A 	

S SERIES

NOTES

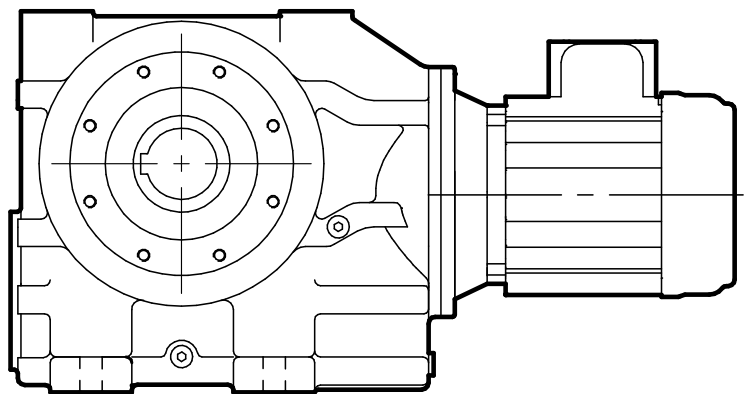
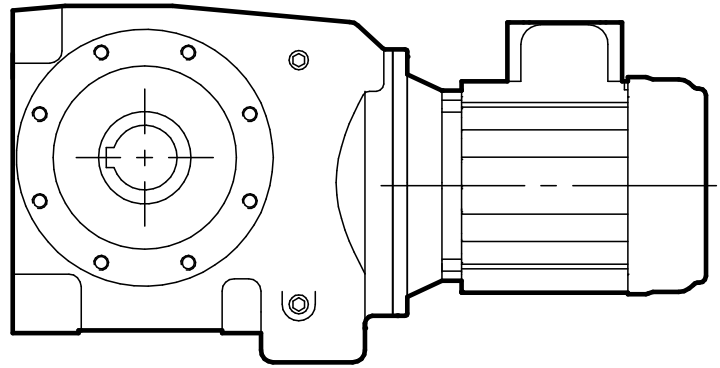

MOTORISED
S SERIES

S SERIES

MOTOR

PERFORMANCE DATA

TEFC Squirrel Cage 3 Phase Motors
4 poles = 1500 rpm 400V, 50Hz, S1
IP55, Class F

P (kW)	Frame Size	n RPM	I (A)	Ist / I	Tst / T	J (kgm ²)
0.12	63	1360	0.6	2.6	2.5	0.0004
0.18	63	1370	0.72	3.0	2.2	0.0005
0.25	71	1370	0.65	3.5	2.0	0.0007
0.37	71	1380	0.88	4.0	2.1	0.0009
0.55	80	1420	1.45	5.0	2.0	0.0015
0.75	80	1420	1.8	5.3	2.7	0.0020
1.1	90S	1430	2.4	6.2	2.7	0.0045
1.5	90L	1430	3.3	6.3	2.7	0.0053
2.2	100L	1450	4.7	6.4	2.9	0.0085
3.0	100L	1450	6.3	7.7	2.9	0.0110
4.0	112M	1450	8.2	7.0	2.9	0.0125
5.5	132S	1450	11.1	5.9	2.0	0.033
7.5	132M	1450	14.8	5.6	2.0	0.036
11	160M	1460	21	6.7	2.2	0.081
15	160L	1460	28.5	7.1	2.6	0.099
18.5	180M	1470	35	7.2	2.6	0.166
22	180L	1470	41	7.3	2.6	0.195
30	200L	1470	56	6.7	2.2	0.31
37	225S	1470	68	7.1	2.6	0.36
45	225M	1480	83	7.5	2.7	0.44
55	250M	1480	98	7.5	2.6	0.77
75	280S	1480	134	6.8	2.5	1.25
90.0	280M	1480	160	7.1	2.5	1.50
110	315S	1480	195	7.7	2.4	2.30
132	315M	1480	232	7.2	2.4	2.60
160	315L	1480	284	7.2	2.4	2.90

TEFC Squirrel Cage 3 Phase Motors
6 poles = 1000 rpm 400V, 50Hz, S1
IP55, Class F

P (kW)	Frame Size	n RPM	I (A)	Ist / I	Tst / T	J (kgm ²)
0.12	63	900	0.57	2.1	2.1	0.0007
0.18	71	900	0.6	3.1	2	0.0009
0.25	71	920	0.77	3.4	2.1	0.0011
0.37	80	920	1.09	3.6	2.2	0.0019
0.55	80	920	1.51	3.8	1.8	0.0024
0.75	90S	930	2.36	4.5	1.8	0.005
1.1	90L	930	3	4	2.3	0.006
1.5	100L	940	3.8	4	1.9	0.009
2.2	112M	940	5.5	4.5	1.7	0.125
3	132S	960	8	5.5	1.8	0.033
4	132M	960	10	4.6	1.7	0.038
5.5	132M	960	12.9	5.1	2	0.045
7.5	160M	970	15.4	7.4	1.7	0.087
11	160L	970	23	7.5	1.9	0.114
15	180L	970	31	6.5	1.8	0.192
18.5	200L	980	36	6.7	2.2	0.380
22	200L	980	43	6.6	2.2	0.440
30	225M	985	56	7	2.6	0.660
37	250M	985	69	6.8	2.7	1.16
45	280S	985	85	7	2.5	1.85
55	280M	985	100	7	2.7	2.20
75	315S	985	139	7.4	2.4	3.20
90	315M	985	163	7.5	2.4	4.10
110	315L	985	201	7.4	2.5	4.90
132	315L	985	240	7.5	2.7	5.60

Key

I = Nominal current Ist/I = Starting current factor Tst/T = Starting torque factor J = Motor moment of inertia
P = Rated output power n = Motor speed T = Rated output torque

Recalculation Factors Fv

Recalculation factors for current at rated voltages other than 400V, 50 Hz.

50 Hz	Fv
220V	1.82
230V	1.74
415V	0,96
500V	0,80
660V	0,61
690V	0,58

60 Hz Operation

Motors wound for a certain voltage at 50 Hz can be operated at 60 Hz, without any modifications, subject to the following changes in their data

60 Hz	P (kW)	n RPM	I (A)	Ist (I)	T (Nm)	Tst (T)
380V	100%	120%	100%	80%	83%	66%
400V	100%	120%	98%	83%	83%	70%
415V	105%	120%	100%	8%8	86%	78%
440V	110%	120%	100%	95%	91%	85%
460V	115%	120%	100%	100%	96%	95%
480V	120%	120%	100%	105%	100%	100%

S SERIES

MOTOR DETAILS

B14 'C' face

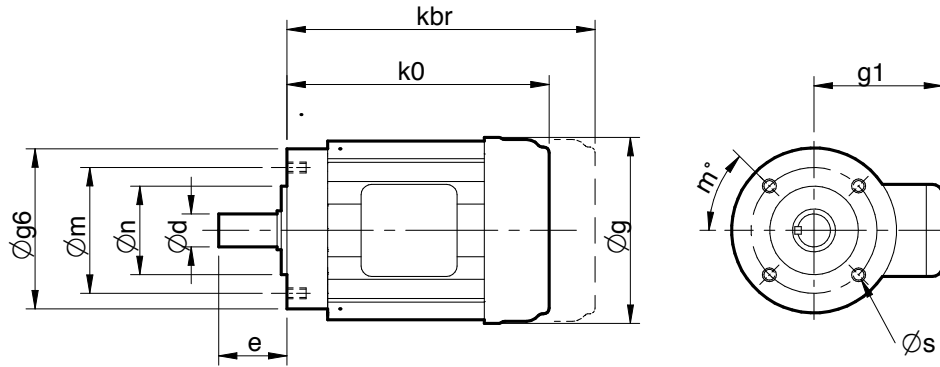

Size	$\varnothing g6$	$\varnothing m$	$\varnothing n$	$\varnothing d$	e	$k0$	kbr	$\varnothing g$	$g1$	m	$\varnothing s$
71	105	85	70	14	30	220	270	140	105	45 deg	4xM6
80	120	100	80	19	40	240	290	158	122	45 deg	4xM6
90S	140	115	95	24	50	260	310	180	129	45 deg	4xM8
90L	140	115	95	24	50	280	330	180	129	45 deg	4xM8
100L	160	130	110	28	60	310	375	198	152	45 deg	4xM8
112M	160	130	110	28	60	330	405	222	165	45 deg	4xM8
132S	200	165	130	38	80	380	475	260	185	45 deg	4xM10
132M	200	165	130	38	80	420	505	260	185	45 deg	4xM10

B5 'D' face

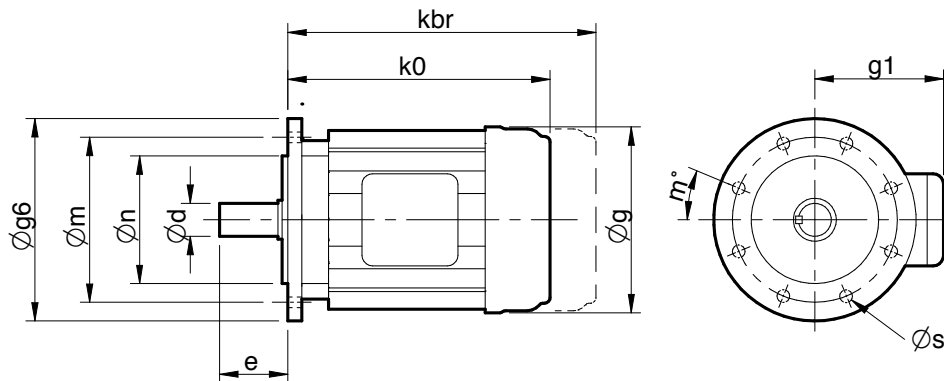

Size	$\varnothing g6$	$\varnothing m$	$\varnothing n$	$\varnothing d$	e	$k0$	kbr	$\varnothing g$	$g1$	m	$\varnothing s$
63	140	115	95	11	23	195	260	125	100	45 deg	4x9 (M8)
71	160	130	110	14	30	220	270	140	105	45 deg	4x9 (M8)
80	200	165	130	19	40	240	290	158	122	45 deg	4x11 (M10)
90S	200	165	130	24	50	260	310	180	129	45 deg	4x11 (M10)
90L	200	165	130	24	50	280	330	180	129	45 deg	4x11 (M10)
100L	250	215	180	28	60	310	375	198	152	45 deg	4x14 (M12)
112M	250	215	180	28	60	330	405	222	165	45 deg	4x14 (M12)
132S	300	265	230	38	80	380	475	260	185	45 deg	4x14 (M12)
132M	300	265	230	38	80	420	505	260	185	45 deg	4x14 (M12)
160M	350	300	250	42	110	480	565	320	264	45 deg	4x18 (M16)
160L	350	300	250	42	110	530	615	320	264	45 deg	4x18 (M16)
180M	350	300	250	48	110	560	-	360	279	45 deg	4x18 (M16)
180L	350	300	250	48	110	595	-	360	279	45 deg	4x18 (M16)
200L	400	350	300	55	110	660	-	400	317	45 deg	4x18 (M16)
225S	450	400	350	60	140	680	-	450	385	22.5 deg	8x18 (M16)
225M	450	400	350	60	140	715	-	450	385	22.5 deg	8x18 (M16)
250M	550	500	450	65	140	770	-	500	405	22.5 deg	8x18 (M16)
280S	550	500	450	75	140	850	-	560	480	22.5 deg	8x18 (M16)
280M	550	500	450	75	140	930	-	560	480	22.5 deg	8x18 (M16)
315S	660	600	550	80	170	1100	-	630	530	22.5 deg	8x22 (M20)
315M	660	600	550	80	170	1260	-	630	530	22.5 deg	8x22 (M20)
315L	660	600	550	80	170	1400	-	630	530	22.5 deg	8x22 (M20)

ADDITIONAL MOTOR FEATURES

Additional Motor Features- Column 19 Entry

Column 19 Entry	Brake Motor	Hand Release on Brake	Forced Ventilation/ Constant Blower (TECB)	Thermistors	Special
-					
A	•				
B	•	•			
C			•		
D	•		•		
E	•	•	•		
F				•	
G	•			•	
H	•	•		•	
K			•	•	
L	•		•	•	
M	•	•	•	•	
S					•

Please refer to Application Engineering for details of the following additional motor features

- PGF encoder flange
- Wash down
- Customised brake torque
- Separate brake supply
- Aluminium fan
- Anti Condensation heater
- Bi-metal temperature detectors, Thermostat
- EExEII T3
- Ex nA II T3
- IP56
- IP65
- Metal fan cover
- Rain cowl
- Separate terminal box

S SERIES

ADDITIONAL GEARBOX FEATURES

Additional Gearbox Features- Column 20 Entry

Column 20 entry	Double Oil Seals on Output Shaft	Oil Level Glass S07- S10	* Motorised Backstop		Special
			CW Rotation	CCW Rotation	
-					
A	•				
B		•			
C	•	•			
D			•		
E	•		•		
F		•	•		
G	•	•	•		
H				•	
I	•			•	
J		•		•	
K	•	•		•	
L					•

Please refer to our Application Engineers for details of the following additional gearbox features

- Prime paint only
- Wash down
- BISSC compatible
- Special oil (food compatible, bio-degradable, different viscosities etc)

* IEC B5 frame sizes 100 - 200 and NEMA frame sizes 182TC -326TC

S SERIES SELECTION TABLE GEARED MOTORS

0.12 kW
4 POLE

N2 RPM	i	M2 Nm	Fm	N	Unit Designation	kg	
Output Speed	Ratio	Output Torque	Service Factor	Overhung Load	Column Entry 1 - 20 Spaces to be filled when entering order	Weight of Base Mount unit	Motor Size
158	8.59	6	13.44	2860	S 0 3 2 1 8 . 0 _ M _ _ _ . 1 2 A - -	14.5	63
117	11.61	8	10.86	2860	1 1 .		
103	13.20	9	9.93	2860	1 2 .		
91	14.95	10	9.07	2860	1 4 .		
83	16.36	10	8.68	2860	1 6 .		
71	19.12	13	7.61	2860	1 8 .		
66	20.61	14	7.21	2860	2 0 .		
62	22.11	13	7.10	2860	2 2 .		
54	25.14	15	6.50	2860	2 5 .		
48	28.48	16	5.98	2860	2 8 .		
40	33.71	22	5.03	2850	3 2 .		
37	36.43	21	5.04	2850	3 6 .		
35	39.26	22	4.80	2850	4 0 .		
30	45.50	30	4.05	2850	4 5 .		
26	53.31	35	3.63	2840	5 0 .		
24	56.19	32	3.74	2850	5 6 .		
21	64.21	36	3.42	2840	6 3 .		
18	74.55	48	2.98	2840	7 1 .		
16	82.83	53	2.76	2830	8 0 .		
16	86.67	48	2.89	2840	9 0 .		
13	101.54	55	2.57	2830	1 0 0		
12	114.33	72	1.78	2820	1 1 2		
10	129.94	82	1.54	2820	1 2 5		
10	142.00	75	1.96	2820	1 4 0		
8.6	157.78	83	1.78	2820	1 6 0		
6.2	217.78	113	1.31	2800	2 1 2		
5.5	247.50	127	1.16	2800	2 5 0		
13.0	105.36	65	2.26	2830	S 0 3 3 1 1 0 0 _ M _ _ _ . 1 2 A - -	17.5	63
11	120.39	75	1.99	2820	1 1 8		
10	130.10	68	2.16	2830	1 3 2		
10	140.21	73	2.03	2820	1 5 0		
8.4	162.50	100	1.49	2810	1 6 0		
7.1	190.38	116	1.27	2800	1 8 0		
6.8	200.68	103	1.45	2810	2 0 0		
5.9	229.32	116	1.27	2800	2 2 5		
5.1	266.25	161	0.92	2780	2 6 5		
4.6	295.83	178	0.84	2770	2 8 0		
4.4	309.52	154	0.96	2780	3 1 5		
3.8	362.64	179	0.83	2770	3 6 0		
16	82.83	53	3.56	5290	S 0 4 2 1 8 0 . _ M _ _ _ . 1 2 A - -	16.5	63
12	114.33	72	1.78	5290	1 1 2		
10	129.94	83	1.54	5290	1 2 5		
10	142.00	77	3.25	5290	1 4 0		
8.6	157.78	85	3.01	5290	1 6 0		
6.2	217.78	115	1.78	5290	2 1 2		
5.5	247.50	130	1.54	5280	2 5 0		
13	105.36	67	3.04	5290	S 0 4 3 1 1 0 0 _ M _ _ _ . 1 2 A - -	20.5	63
11	120.39	76	2.66	5290	1 1 8		
10	130.10	70	3.40	5290	1 3 2		
10	140.21	75	3.25	5290	1 5 0		
8.4	162.50	102	1.97	5290	1 6 0		
7.1	190.38	118	1.69	5290	1 8 0		
6.8	200.68	105	2.61	5290	2 0 0		
5.9	229.32	120	2.31	5290	2 2 5		
5.1	266.25	164	1.20	5270	2 6 5		
4.6	295.83	181	1.09	5270	2 8 0		
4.4	309.52	159	1.74	5280	3 1 5		
3.8	362.64	185	1.50	5270	3 6 0		
2.7	507.14	254	1.09	5240	5 0 0		
5.7	240.00	131	3.67	7440	S 0 5 2 1 2 5 0 _ M _ _ _ . 1 2 A - -	18.5	63
8.5	160.26	103	3.82	7440	S 0 5 3 1 1 6 0 _ M _ _ _ . 1 2 A - -	21.5	63
7.2	187.76	120	3.27	7440	1 8 0		
5.9	229.81	125	3.85	7440	2 2 5		
5.2	262.58	165	2.34	7440	2 6 5		
4.7	291.75	183	2.11	7440	2 8 0		
4.4	310.18	165	2.91	7440	3 1 5		
3.7	363.40	192	2.50	7440	3 6 0		
3.4	402.70	251	1.53	7440	4 0 0		
3.0	457.66	285	1.34	7440	4 5 0		
2.7	508.21	264	1.82	7440	5 0 0		
2.4	564.68	292	1.65	7440	5 6 0		
1.7	779.42	397	1.21	7430	8 0 0		
1.5	885.79	450	1.07	7420	9 0 0		
4.5	299.67	200	3.83	11800	S 0 6 3 1 2 8 0 _ M _ _ _ . 1 2 A - -	37.5	63
3.8	357.32	200	3.83	11900	3 6 0		
3.4	395.39	262	2.92	11800	4 0 0		
3.0	449.50	296	2.59	11800	4 5 0		
2.6	514.75	281	2.72	11800	5 0 0		
2.3	580.00	315	2.43	11800	5 6 0		
1.8	765.28	410	1.87	11700	8 0 0		
1.6	870.00	462	1.66	11700	9 0 0		

NOTE

Other output speeds are available using 2 and 8 pole motors. Please contact our Application Engineers

S SERIES SELECTION TABLE GEARED MOTORS

0.12 kW

4 POLE

0.12 kW

6 POLE

NOTE

Other output speeds are available using 2 and 8 pole motors. Please contact our Application Engineers

N2 RPM	i	M2 Nm	Fm	N	Unit Designation	kg	
Output Speed	Ratio	Output Torque	Service Factor	Overhung Load	Column Entry 1 - 20 Spaces to be filled when entering order	Weight of Base Mount unit	Motor Size
1.3	1021.77	655	1.17	11402	S 0 6 4 1 1 0 C _ M _ _ _ _ . 1 2 A _ _	50.5	63
1.2	1110.85	711	1.08	11402	1 1 C		
1.0	1299.84	815	0.94	11402	1 2 C		
0.91	1495.14	937	0.82	11402	1 4 C		
2.7	499.88	321	3.95	29200	S 0 7 3 1 5 0 0 _ M _ _ _ _ . 1 2 A _ _	84.5	63
2.5	547.35	350	3.62	29200	5 6 0		
1.8	747.66	471	2.67	29200	8 0 0		
1.6	838.50	526	2.39	29200	9 0 0		
1.3	1009.20	679	1.97	28931	S 0 7 4 1 1 0 C _ M _ _ _ _ . 1 2 A _ _	88.5	63
1.2	1097.19	738	1.82	28931	1 1 C		
1.1	1213.28	806	1.66	28931	1 2 C		
0.97	1395.57	926	1.45	28931	1 4 C		
0.90	1517.24	1006	1.33	28931	1 6 C		
0.82	1661.54	1097	1.22	28931	1 8 C		
0.68	1994.66	1314	1.02	28931	2 0 C		
0.62	2185.71	1441	0.93	28931	2 2 C		
0.55	2462.77	1619	0.83	28931	2 5 C		
1.3	1083.79	737	3.86	41656	S 0 8 4 1 1 1 C _ M _ _ _ _ . 1 2 A _ _	141.5	63
1.1	1191.45	812	3.34	41656	1 2 C		
0.97	1404.96	954	2.84	41656	1 4 C		
0.89	1532.14	1030	3.18	41545	1 6 C		
0.72	1901.25	1276	2.57	41545	1 8 C		
0.65	2088.45	1396	2.40	41545	2 0 C		
0.61	2241.96	1501	2.18	41545	2 2 C		
0.55	2462.71	1643	2.04	41545	2 5 C		
0.50	2696.62	1797	1.87	41545	2 8 C		
0.41	3304.80	2194	1.53	41545	3 2 C		
0.36	3760.71	2492	1.31	41545	3 6 C		
0.71	1908.45	1307	3.77	53383	S 0 9 4 1 1 8 C _ M _ _ _ _ . 1 2 A _ _	209.5	63
0.65	2106.88	1440	3.44	53383	2 0 C		
0.60	2250.46	1538	3.20	53383	2 2 C		
0.55	2484.44	1694	2.92	53383	2 5 C		
0.50	2720.42	1852	2.67	53383	2 8 C		
0.41	3333.96	2262	2.19	53383	3 2 C		
0.36	3774.96	2554	1.93	53383	3 6 C		
101	8.59	9	9.52	2860	S 0 3 2 1 8 . 0 _ M _ _ _ _ . 1 2 C _ _	14.5	63
75	11.61	12	7.78	2860	1 1 .		
66	13.20	14	7.04	2860	1 2 .		
58	14.95	15	6.45	2860	1 4 .		
53	16.36	15	6.26	2860	1 6 .		
45	19.12	20	5.38	2850	1 8 .		
42	20.61	21	5.11	2850	2 0 .		
39	22.11	20	5.11	2850	2 2 .		
35	25.14	22	4.67	2850	2 5 .		
31	28.48	25	4.29	2850	2 8 .		
26	33.71	34	3.59	2850	3 2 .		
24	36.43	32	3.61	2850	3 6 .		
22	39.26	34	3.43	2850	4 0 .		
19	45.50	46	2.98	2840	4 5 .		
16	53.31	53	2.70	2830	5 0 .		
15	56.19	49	2.67	2840	5 6 .		
14	64.21	55	2.44	2830	6 3 .		
12	74.55	74	2.01	2820	7 1 .		
11	82.83	81	1.82	2820	8 0 .		
10	86.67	73	2.04	2830	9 0 .		
8.6	101.54	84	1.76	2820	1 0 0		
7.6	114.33	112	1.14	2800	1 1 2		
6.7	129.94	126	0.99	2800	1 2 5		
6.1	142.00	116	1.28	2800	1 4 0		
5.5	157.78	128	1.16	2800	1 6 0		
4.0	217.78	174	0.85	2770	2 1 2		
8.3	105.36	102	1.46	2810	S 0 3 3 1 1 0 0 _ M _ _ _ _ . 1 2 C _ _	17.5	63
7.2	120.39	116	1.28	2800	1 1 8		
6.7	130.10	104	1.42	2810	1 3 2		
6.2	140.21	112	1.32	2800	1 5 0		
5.4	162.50	155	0.96	2780	1 6 0		
4.6	190.38	181	0.82	2770	1 8 0		
4.3	200.68	157	0.94	2780	2 0 0		
3.8	229.32	179	0.83	2770	2 2 5		
16	53.31	54	3.78	5290	S 0 4 2 1 5 0 . _ M _ _ _ _ . 1 2 C _ _	16.5	63
14	64.21	56	3.90	5290	6 3 .		
12	74.55	74	2.71	5290	7 1 .		

S SERIES SELECTION TABLE GEARED MOTORS

012.kW
6 POLE

N2 RPM	i	M2 Nm	Fm	N	Unit Designation	kg	
Output Speed	Ratio	Output Torque	Service Factor	Overhung Load	Column Entry 1 - 20 Spaces to be filled when entering order	Weight of Base Mount unit	Motor Size
11	82.83	82	2.28	5290	S 0 4 2 1 8 0 . _ M _ _ _ . 1 2 C - -	16.5	63
10	86.67	74	3.31	5290	9 0 .		
8.6	101.54	86	2.95	5290	1 0 0		
7.6	114.33	113	1.14	5290	1 1 2		
6.7	129.94	127	0.99	5280	1 2 5		
6.1	142.00	118	2.35	5290	1 4 0		
5.5	157.78	130	2.13	5280	1 6 0		
4.0	217.78	176	1.14	5270	2 1 2		
3.5	247.50	198	0.99	5260	2 5 0		
8.3	105.36	103	1.94	5290	S 0 4 3 1 1 0 0 _ M _ _ _ . 1 2 C - -	20.5	63
7.2	120.39	117	1.70	5290	1 1 8		
6.7	130.10	107	2.55	5290	1 3 2		
6.2	140.21	115	2.40	5290	1 5 0		
5.4	162.50	156	1.26	5280	1 6 0		
4.6	190.38	182	1.08	5270	1 8 0		
4.3	200.68	162	1.71	5280	2 0 0		
3.8	229.32	184	1.51	5270	2 2 5		
2.8	309.52	243	1.14	5250	3 1 5		
2.4	362.64	283	0.98	5240	3 6 0		
8.0	109.07	111	3.49	7440	S 0 5 2 1 1 1 2 _ M _ _ _ . 1 2 C - -	18.5	63
7.0	124.00	125	3.04	7440	1 2 5		
6.1	142.00	122	3.93	7440	1 4 0		
5.4	160.00	136	3.52	7440	1 6 0		
4.1	211.11	178	2.70	7440	2 1 2		
3.6	240.00	200	2.40	7440	2 5 0		
8.4	103.90	105	3.76	7440	S 0 5 3 1 1 0 0 _ M _ _ _ . 1 2 C - -	21.5	63
7.3	118.73	119	3.29	7440	1 1 8		
5.4	160.26	159	2.45	7440	1 6 0		
4.6	187.76	186	2.08	7440	1 8 0		
4.3	201.10	168	2.85	7440	2 0 0		
3.8	229.81	191	2.51	7440	2 2 5		
3.3	262.58	257	1.50	7440	2 6 5		
3.0	291.75	284	1.35	7440	2 8 0		
2.8	310.18	254	1.90	7440	3 1 5		
2.4	363.40	295	1.63	7440	3 6 0		
2.2	402.70	391	0.97	7430	4 0 0		
1.9	457.66	441	0.86	7420	4 5 0		
1.7	508.21	406	1.19	7430	5 0 0		
1.5	564.68	449	1.07	7420	5 6 0		
7.0	124.00	132	3.95	11900	S 0 6 2 1 1 2 5 _ M _ _ _ . 1 2 C - -	32.5	63
3.6	240.00	211	3.62	11900	2 5 0		
4.7	184.62	193	3.95	11900	S 0 6 3 1 1 8 0 _ M _ _ _ . 1 2 C - -	37.5	63
3.3	265.95	275	2.78	11800	2 6 5		
2.9	299.67	309	2.48	11800	2 8 0		
2.6	328.67	282	2.71	11800	3 1 5		
2.4	357.32	305	2.51	11800	3 6 0		
2.2	395.39	405	1.89	11700	4 0 0		
1.9	449.50	458	1.67	11700	4 5 0		
1.7	514.75	431	1.77	11700	5 0 0		
1.5	580.00	482	1.59	11700	5 6 0		
1.1	765.28	629	1.22	11600	8 0 0		
1.0	870.00	709	1.08	11500	9 0 0		
2.7	319.95	323	3.93	29200	S 0 7 3 1 3 1 5 _ M _ _ _ . 1 2 C - -	84.5	63
2.5	341.61	344	3.69	29200	3 6 0		
2.3	373.83	400	3.35	29200	4 0 0		
2.1	419.25	446	3.00	29200	4 5 0		
1.7	499.88	495	2.55	29200	5 0 0		
1.6	547.35	539	2.33	29200	5 6 0		
1.2	747.66	731	1.72	29200	8 0 0		
1.0	838.50	817	1.54	29200	9 0 0		
0.86	1009.20	1059	1.27	28931	S 0 7 4 1 1 0 C _ M _ _ _ . 1 2 C - -	88.5	63
0.79	1097.19	1150	1.17	28931	1 1 C		
0.72	1213.28	1260	1.06	28931	1 2 C		
0.62	1395.57	1446	0.93	28931	1 4 C		
0.57	1517.24	1570	0.85	28931	1 6 C		
1.4	636.31	682	3.98	41656	S 0 8 4 1 6 3 0 _ M _ _ _ . 1 2 C - -	141.5	63
1.2	711.92	761	3.57	41656	7 1 0		
1.1	758.79	812	3.34	41656	8 0 0		
0.97	899.27	959	2.83	41656	9 0 0		
0.91	960.14	1023	2.65	41656	1 0 C		
0.80	1083.79	1151	2.47	41656	1 1 C		
0.73	1191.45	1264	2.15	41656	1 2 C		
0.62	1404.96	1484	1.83	41656	1 4 C		
0.57	1532.14	1610	2.03	41545	1 6 C		
0.46	1901.25	1991	1.64	41545	1 8 C		
0.42	2088.45	2180	1.54	41545	2 0 C		
0.39	2241.96	2340	1.40	41545	2 2 C		
0.35	2462.71	2563	1.31	41545	2 5 C		
0.32	2696.62	2801	1.20	41545	2 8 C		
0.26	3304.80	3414	0.98	41545	3 2 C		

NOTE
Other output speeds are available using 2 and 8 pole motors. Please contact our Application Engineers

S SERIES SELECTION TABLE GEARED MOTORS

012.kW
6 POLE

0.18 kW
4 POLE

N2 RPM	i	M2 Nm	Fm	N	Unit Designation	kg			
Output Speed	Ratio	Output Torque	Service Factor	Overhung Load	Column Entry 1 - 20 Spaces to be filled when entering order	Weight of Base Mount unit	Motor Size		
0.23	3760.71	3866	0.85	41545	S 0 8 4 1 3 6 C _ M _ _ _ . 1 2 C _ _	141.5	63		
0.72	1216.09	1319	3.62	53383	S 0 9 4 1 1 2 C _ M _ _ _ . 1 2 C _ _	209.5	63		
0.61	1434.02	1549	3.09	53383	1 4 C				
0.57	1537.95	1649	2.99	53383	1 6 C				
0.46	1908.45	2039	2.41	53383	1 8 C				
0.41	2106.88	2247	2.20	53383	2 0 C				
0.39	2250.46	2397	2.05	53383	2 2 C				
0.35	2484.44	2641	1.88	53383	2 5 C				
0.32	2720.42	2886	1.72	53383	2 8 C				
0.26	3333.96	3518	1.41	53383	3 2 C				
0.23	3774.96	3963	1.24	53383	3 6 C				
159	8.59	8	9.03	2858	S 0 3 2 1 8 . 0 _ M _ _ _ . 1 8 A _ _	14.5	63		
118	11.61	12	7.30	2857	1 1 .				
104	13.20	13	6.67	2857	1 2 .				
92	14.95	15	6.09	2857	1 4 .				
84	16.36	14	5.83	2856	1 6 .				
72	19.12	19	5.11	2856	1 8 .				
66	20.61	20	4.84	2856	2 0 .				
62	22.11	19	4.77	2856	2 2 .				
54	25.14	22	4.36	2855	2 5 .				
48	28.48	25	4.02	2855	2 8 .				
41	33.71	33	3.38	2844	3 2 .				
38	36.43	31	3.39	2844	3 6 .				
35	39.26	34	3.22	2844	4 0 .				
30	45.50	44	2.72	2841	4 5 .				
26	53.31	52	2.44	2831	5 0 .				
24	56.19	47	2.51	2841	5 6 .				
21	64.21	54	2.29	2830	6 3 .				
18	74.55	71	2.00	2825	7 1 .				
17	82.83	79	1.85	2818	8 0 .				
16	86.67	71	1.94	2825	9 0 .				
13	101.54	82	1.73	2816	1 0 0				
12	114.33	107	1.20	2801	1 1 2				
11	129.94	122	1.03	2796	1 2 5				
10	142.00	113	1.32	2801	1 4 0				
8.7	157.78	124	1.20	2796	1 6 0				
6.3	217.78	168	0.88	2770	2 1 2				
13	105.36	98	1.52	2810	S 0 3 3 1 1 0 0 _ M _ _ _ . 1 8 A _ _	17.5	63		
11	120.39	111	1.33	2801	1 1 8				
11	130.10	102	1.45	2811	1 3 2				
10	140.21	109	1.36	2801	1 5 0				
8.4	162.50	149	1.00	2782	1 6 0				
7.2	190.38	174	0.86	2770	1 8 0				
6.8	200.68	153	0.97	2780	2 0 0				
6.0	229.32	174	0.86	2770	2 2 5				
26	53.31	52	3.97	5286	S 0 4 2 1 5 0 0 _ M _ _ _ . 1 8 A _ _			16.5	63
21	64.21	55	3.67	5286	6 3 .				
18	74.55	72	2.84	5284	7 1 .				
17	82.83	80	2.39	5284	8 0 .				
16	86.67	73	3.11	5287	9 0 .				
13	101.54	84	2.77	5285	1 0 0				
12	114.33	108	1.20	5280	1 1 2				
11	129.94	123	1.03	5278	1 2 5				
10	142.00	115	2.18	5280	1 4 0				
8.7	157.78	127	2.02	5278	1 6 0				
6.3	217.78	172	1.20	5271	2 1 2				
5.5	247.50	194	1.03	5261	2 5 0				
13	105.36	99	2.04	5281	S 0 4 3 1 1 0 0 _ M _ _ _ . 1 8 A _ _	20.5	63		
11	120.39	113	1.78	5280	1 1 8				
11	130.10	104	2.28	5281	1 3 2				
10	140.21	112	2.18	5280	1 5 0				
8.4	162.50	151	1.32	5275	1 6 0				
7.2	190.38	176	1.13	5270	1 8 0				
6.8	200.68	157	1.75	5275	2 0 0				
6.0	229.32	178	1.55	5271	2 2 5				
5.1	266.25	244	0.81	5246	2 6 5				
4.4	309.52	237	1.17	5250	3 1 5				
3.8	362.64	275	1.01	5240	3 6 0				
13	109.07	107	3.66	7438	S 0 5 2 1 1 1 2 _ M _ _ _ . 1 8 A _ _	18.5	63		
11	124.00	121	3.19	7438	1 2 5				
8.6	160.00	133	3.61	7436	1 6 0				
6.5	211.11	173	2.78	7433	2 1 2				
5.7	240.00	195	2.47	7437	2 5 0				

NOTE

Other output speeds are available using 2 and 8 pole motors. Please contact our Application Engineers

S SERIES SELECTION TABLE GEARED MOTORS

0.18 kW

4 POLE

N2 RPM	i	M2 Nm	Fm	N	Unit Designation	kg	
Output Speed	Ratio	Output Torque	Service Factor	Overhung Load	Column Entry 1 - 20 Spaces to be filled when entering order	Weight of Base Mount unit	Motor Size
13	103.90	101	3.95	7436	S 0 5 3 1 1 0 0 _ M _ _ _ _ . 1 8 A _ _	21.5	63
12	118.73	115	3.46	7435	1 1 8		
8.5	160.26	153	2.57	7434	1 6 0		
7.3	187.76	179	2.19	7434	1 8 0		
6.8	201.10	163	2.94	7435	2 0 0		
6.0	229.81	186	2.59	7434	2 2 5		
5.2	262.58	247	1.57	7432	2 6 5		
4.7	291.75	273	1.42	7430	2 8 0		
4.4	310.18	246	1.95	7432	3 1 5		
3.8	363.40	286	1.68	7428	3 6 0		
3.4	402.70	374	1.03	7421	4 0 0		
3.0	457.66	425	0.90	7416	4 5 0		
2.7	508.21	394	1.22	7421	5 0 0		
2.4	564.68	435	1.11	7420	5 6 0		
1.8	779.42	592	0.81	7390	8 0 0		
5.7	240.00	206	3.71	11852	S 0 6 2 1 2 5 0 _ M _ _ _ _ . 1 8 A _ _	32.5	63
5.2	265.95	265	2.89	11830	S 0 6 3 1 2 6 5 _ M _ _ _ _ . 1 8 A _ _	37.5	63
4.6	299.67	297	2.57	11728	2 8 0		
4.2	328.67	275	2.78	11828	3 1 5		
3.8	357.32	297	2.57	11828	3 6 0		
3.5	395.39	390	1.96	11704	4 0 0		
3.0	449.50	440	1.74	11661	4 5 0		
2.7	514.75	419	1.83	11707	5 0 0		
2.4	580.00	469	1.63	11707	5 6 0		
1.8	765.28	610	1.25	11600	8 0 0		
1.6	870.00	688	1.11	11500	9 0 0		
4.0	341.61	330	3.84	28143	S 0 7 3 1 3 6 0 _ M _ _ _ _ . 1 8 A _ _	84.5	63
3.7	373.83	384	3.49	27930	4 0 0		
3.3	419.25	429	3.12	29161	4 5 0		
2.7	499.88	479	2.65	29152	5 0 0		
2.5	547.35	522	2.43	29152	5 6 0		
1.8	747.66	701	1.80	29130	8 0 0		
1.6	838.50	784	1.61	29116	9 0 0		
1.4	1009.20	1012	1.33	28931	S 0 7 4 1 1 0 0 C _ M _ _ _ _ . 1 8 A _ _	88.5	63
1.2	1097.19	1099	1.22	28931	1 1 C		
1.1	1213.28	1201	1.12	28931	1 2 C		
0.98	1395.57	1379	0.97	28931	1 4 C		
0.90	1517.24	1498	0.90	28931	1 6 C		
0.82	1661.54	1634	0.82	28931	1 8 C		
1.9	711.92	726	3.74	41656	S 0 8 4 1 7 1 0 _ M _ _ _ _ . 1 8 A _ _	141.5	63
1.8	758.79	774	3.51	41656	8 0 0		
1.5	899.27	916	2.96	41656	9 0 0		
1.4	960.14	977	2.78	41656	1 0 C		
1.3	1083.79	1098	2.59	41656	1 1 C		
1.1	1191.45	1209	2.25	41656	1 2 C		
0.98	1404.96	1421	1.91	41656	1 4 C		
0.89	1532.14	1534	2.14	41545	1 6 C		
0.72	1901.25	1900	1.72	41545	1 8 C		
0.66	2088.45	2079	1.61	41545	2 0 C		
0.61	2241.96	2236	1.47	41545	2 2 C		
0.56	2462.71	2447	1.37	41545	2 5 C		
0.51	2696.62	2676	1.25	41545	2 8 C		
0.41	3304.80	3268	1.03	41545	3 2 C		
0.36	3760.71	3711	0.88	41545	3 6 C		
1.1	1216.09	1261	3.79	53383	S 0 9 4 1 1 2 C _ M _ _ _ _ . 1 8 A _ _	209.5	63
0.96	1434.02	1483	3.22	53383	1 4 C		
0.89	1537.95	1572	3.13	53383	1 6 C		
0.72	1908.45	1947	2.53	53383	1 8 C		
0.65	2106.88	2144	2.31	53383	2 0 C		
0.61	2250.46	2291	2.15	53383	2 2 C		
0.55	2484.44	2523	1.96	53383	2 5 C		
0.50	2720.42	2759	1.80	53383	2 8 C		
0.41	3333.96	3368	1.47	53383	3 2 C		
0.36	3774.96	3803	1.30	53383	3 6 C		

NOTE

Other output speeds are available using 2 and 8 pole motors. Please contact our Application Engineers

S SERIES SELECTION TABLE GEARED MOTORS

0.18 kW

6 POLE

N2 RPM	i	M2 Nm	Fm	N	Unit Designation	kg	
Output Speed	Ratio	Output Torque	Service Factor	Overhung Load	Column Entry 1 - 20 Spaces to be filled when entering order	Weight of Base Mount unit	Motor Size
105	8.59	13	6.56	2857	S 0 3 2 1 8 . 0 _ M _ _ _ . 1 8 C - -	15.5	71
78	11.61	17	5.36	2856	1 1 .		
68	13.20	20	4.85	2856	1 2 .		
60	14.95	22	4.45	2855	1 4 .		
55	16.36	22	4.32	2855	1 6 .		
47	19.12	29	3.71	2845	1 8 .		
44	20.61	31	3.52	2844	2 0 .		
41	22.11	29	3.53	2845	2 2 .		
36	25.14	33	3.22	2844	2 5 .		
32	28.48	37	2.96	2843	2 8 .		
27	33.71	50	2.48	2840	3 2 .		
25	36.43	46	2.49	2841	3 6 .		
23	39.26	50	2.36	2840	4 0 .		
20	45.50	67	2.06	2827	4 5 .		
17	53.31	77	1.86	2816	5 0 .		
16	56.19	71	1.84	2827	5 6 .		
14	64.21	80	1.68	2816	6 3 .		
12	74.55	107	1.39	2800	7 1 .		
11	82.83	118	1.26	2798	8 0 .		
10	86.67	105	1.41	2810	9 0 .		
8.9	101.54	122	1.21	2796	1 0 0		
6.3	142.00	168	0.89	2772	1 4 0		
5.7	157.78	185	0.80	2338	1 6 0		
8.5	105.36	148	1.01	2135	S 0 3 3 1 1 0 0 _ M _ _ _ . 1 8 C - -	19.5	71
7.5	120.39	168	0.89	2772	1 1 8		
6.9	130.10	152	0.98	2782	1 3 2		
6.4	140.21	163	0.91	2772	1 5 0		
25	36.43	48	3.97	5286	S 0 4 2 1 3 6 . _ M _ _ _ . 1 8 C - -	18.5	71
23	39.26	51	3.79	5286	4 0 .		
20	45.50	67	3.05	5285	4 5 .		
17	53.31	79	2.60	5284	5 0 .		
16	56.19	72	2.95	5285	5 6 .		
14	64.21	81	2.69	5283	6 3 .		
12	74.55	108	1.87	5281	7 1 .		
11	82.83	120	1.57	5278	8 0 .		
10	86.67	108	2.28	5280	9 0 .		
8.9	101.54	125	2.03	5278	1 0 0		
6.3	142.00	171	1.62	5273	1 4 0		
5.7	157.78	189	1.47	5263	1 6 0		
8.5	105.36	150	1.34	5276	S 0 4 3 1 1 0 0 _ M _ _ _ . 1 8 C - -	21.5	71
7.5	120.39	170	1.17	5273	1 1 8		
6.9	130.10	156	1.76	5274	1 3 2		
6.4	140.21	167	1.66	5273	1 5 0		
5.5	162.50	227	0.87	5256	1 6 0		
4.5	200.68	235	1.18	5256	2 0 0		
3.9	229.32	266	1.04	5242	2 2 5		
12	73.37	109	3.64	7436	S 0 5 2 1 7 1 . _ M _ _ _ . 1 8 C - -	21.5	71
11	82.67	123	3.23	7435	8 0 .		
9.1	98.57	126	3.81	7435	1 0 0		
8.3	109.07	161	2.41	7434	1 1 2		
7.3	124.00	181	2.09	7434	1 2 5		
6.3	142.00	177	2.71	7434	1 4 0		
5.6	160.00	198	2.43	7431	1 6 0		
4.3	211.11	258	1.86	6731	2 1 2		
3.8	240.00	291	1.66	7428	2 5 0		
8.7	103.90	152	2.59	7037	S 0 5 3 1 1 0 0 _ M _ _ _ . 1 8 C - -	25.5	71
7.6	118.73	173	2.27	6984	1 1 8		
6.9	130.38	162	2.96	6984	1 3 2		
6.4	140.51	174	2.77	6984	1 5 0		
5.6	160.26	231	1.69	6731	1 6 0		
4.8	187.76	269	1.44	7427	1 8 0		
4.5	201.10	244	1.97	7430	2 0 0		
3.9	229.81	277	1.73	7427	2 2 5		
3.4	262.58	373	1.03	7420	2 6 5		
3.1	291.75	411	0.93	7418	2 8 0		
2.9	310.18	368	1.31	7423	3 1 5		
2.5	363.40	428	1.12	7094	3 6 0		
1.8	508.21	589	0.82	7393	5 0 0		
7.3	124.00	192	2.72	11852	S 0 6 2 1 1 2 5 _ M _ _ _ . 1 8 C - -	34.5	71
5.7	156.67	206	3.71	11852	1 6 0		
4.2	214.00	275	2.78	11833	2 1 2		
3.8	240.00	307	2.49	11823	2 5 0		
5.3	169.81	259	2.95	11833	S 0 6 3 1 1 6 0 _ M _ _ _ . 1 8 C - -	39.5	71
4.9	184.62	281	2.72	11823	1 8 0		
3.4	265.95	399	1.92	11702	2 6 5		
3.0	299.67	448	1.71	11680	2 8 0		
2.7	328.67	409	1.87	11704	3 1 5		
2.5	357.32	442	1.73	11704	3 6 0		
2.3	395.39	588	1.30	11556	4 0 0		
2.0	449.50	665	1.15	11515	4 5 0		
1.7	514.75	625	1.22	11561	5 0 0		

NOTE

Other output speeds are available using 2 and 8 pole motors. Please contact our Application Engineers

S SERIES SELECTION TABLE GEARED MOTORS

0.18 kW
6 POLE

N2 RPM	i	M2 Nm	Fm	N	Unit Designation	kg	
Output Speed	Ratio	Output Torque	Service Factor	Overhung Load	Column Entry 1 - 20 Spaces to be filled when entering order	Weight of Base Mount unit	Motor Size
1.6	580.00	700	1.09	11515	S 0 6 3 1 5 6 0 _ M _ _ _ _ . 1 8 C _ _	39.5	71
1.2	765.28	913	0.84	11400	8 0 0		
4.0	226.39	334	3.79	29180	S 0 7 3 1 2 2 5 _ M _ _ _ _ . 1 8 C _ _	86.5	71
3.6	249.94	392	3.41	29171	2 6 5		
3.3	273.68	428	3.12	29161	2 8 0		
2.8	319.95	468	2.71	29161	3 1 5		
2.6	341.61	499	2.54	29152	3 6 0		
2.4	373.83	580	2.31	29144	4 0 0		
2.1	419.25	648	2.07	29144	4 5 0		
1.8	499.88	717	1.76	29130	5 0 0		
1.6	547.35	782	1.61	29116	5 6 0		
1.2	747.66	1061	1.19	29080	8 0 0		
1.1	838.50	1185	1.06	29056	9 0 0		
0.89	1009.20	1536	0.87	28931	S 0 7 4 1 1 0 C _ M _ _ _ _ . 1 8 C _ _	90.5	71
0.82	1097.19	1667	0.80	28931	1 1 C		
1.6	547.09	852	3.19	41656	S 0 8 4 1 5 6 0 _ M _ _ _ _ . 1 8 C _ _	143.5	71
1.4	636.31	989	2.74	41656	6 3 0		
1.3	711.92	1104	2.46	41656	7 1 0		
1.2	758.79	1177	2.31	41656	8 0 0		
1.0	899.27	1391	1.95	41656	9 0 0		
0.94	960.14	1484	1.83	41656	1 0 C		
0.83	1083.79	1669	1.70	41656	1 1 C		
0.76	1191.45	1833	1.48	41656	1 2 C		
0.64	1404.96	2152	1.26	41656	1 4 C		
0.59	1532.14	2335	1.40	41545	1 6 C		
0.47	1901.25	2887	1.13	41545	1 8 C		
0.43	2088.45	3162	1.06	41545	2 0 C		
0.40	2241.96	3394	0.97	41545	2 2 C		
0.37	2462.71	3716	0.90	41545	2 5 C		
0.33	2696.62	4061	0.83	41545	2 8 C		
1.2	774.48	1227	3.90	53383	S 0 9 4 1 8 0 0 _ M _ _ _ _ . 1 8 C _ _	211.5	71
0.98	917.87	1451	3.29	53383	9 0 0		
0.92	980.00	1547	3.09	53383	1 0 C		
0.83	1088.78	1713	2.81	53383	1 1 C		
0.74	1216.09	1912	2.50	53383	1 2 C		
0.63	1434.02	2246	2.13	53383	1 4 C		
0.59	1537.95	2391	2.06	53383	1 6 C		
0.47	1908.45	2957	1.67	53383	1 8 C		
0.43	2106.88	3258	1.52	53383	2 0 C		
0.40	2250.46	3476	1.42	53383	2 2 C		
0.36	2484.44	3830	1.29	53383	2 5 C		
0.33	2720.42	4185	1.18	53383	2 8 C		
0.27	3333.96	5102	0.97	53383	3 2 C		
0.24	3774.96	5746	0.86	53383	3 6 C		
163	8.59	12	6.64	2856	S 0 3 2 1 8 . 0 _ M _ _ _ _ . 2 5 A _ _	15.5	71
121	11.61	16	5.37	2855	1 1 .		
106	13.20	18	4.90	2854	1 2 .		
94	14.95	20	4.48	2854	1 4 .		
86	16.36	20	4.29	2853	1 6 .		
73	19.12	26	3.76	2852	1 8 .		
68	20.61	28	3.56	2852	2 0 .		
63	22.11	26	3.51	2852	2 2 .		
56	25.14	30	3.21	2849	2 5 .		
49	28.48	34	2.95	2849	2 8 .		
42	33.71	45	2.49	2837	3 2 .		
38	36.43	42	2.49	2837	3 6 .		
36	39.26	46	2.37	2837	4 0 .		
31	45.50	60	2.00	2831	4 5 .		
26	53.31	70	1.79	2821	5 0 .		
25	56.19	64	1.85	2831	5 6 .		
22	64.21	73	1.69	2818	6 3 .		
19	74.55	97	1.47	2808	7 1 .		
17	82.83	107	1.36	2804	8 0 .		
16	86.67	97	1.43	2808	9 0 .		
14	101.54	112	1.27	2800	1 0 0		
12	114.33	146	0.88	2780	1 1 2		
10	142.00	153	0.97	2780	1 4 0		
8.9	157.78	169	0.88	2770	1 6 0		
13	105.36	133	1.12	2788	S 0 3 3 1 1 0 0 _ M _ _ _ _ . 2 5 A _ _	19.5	71
12	120.39	151	0.98	2780	1 1 8		
11	130.10	138	1.07	2790	1 3 2		
10	140.21	148	1.00	2780	1 5 0		

NOTE

Other output speeds are available using 2 and 8 pole motors. Please contact our Application Engineers

S SERIES SELECTION TABLE GEARED MOTORS

0.25 kW

4 POLE

N2 RPM	i	M2 Nm	Fm	N	Unit Designation	kg	
Output Speed	Ratio	Output Torque	Service Factor	Overhung Load	Column Entry 1 - 20 Spaces to be filled when entering order	Weight of Base Mount unit	Motor Size
38	36.43	44	3.98	5286	S 0 4 2 1 3 6 . _ M _ - _ - _ . 2 5 A - -	18.5	71
36	39.26	47	3.78	5286	4 0 .		
31	45.50	61	3.35	5285	4 5 .		
26	53.31	71	2.92	5281	5 0 .		
25	56.19	66	2.96	5283	5 6 .		
22	64.21	74	2.70	5281	6 3 .		
19	74.55	98	2.09	5277	7 1 .		
17	82.83	109	1.76	5277	8 0 .		
16	86.67	99	2.29	5284	9 0 .		
14	101.54	114	2.04	5279	1 0 0		
12	114.33	147	0.88	5269	1 1 2		
10	142.00	156	1.61	5269	1 4 0		
8.9	157.78	172	1.49	5264	1 6 0		
6.4	217.78	233	0.88	5250	2 1 2		
13	105.36	135	1.50	5271	S 0 4 3 1 1 0 0 _ M _ - _ - _ . 2 5 A - -	21.5	71
12	120.39	154	1.31	5268	1 1 8		
11	130.10	142	1.68	5271	1 3 2		
10	140.21	152	1.61	5269	1 5 0		
8.6	162.50	206	0.97	5258	1 6 0		
7.4	190.38	239	0.83	5248	1 8 0		
7.0	200.68	213	1.29	5258	2 0 0		
6.1	229.32	243	1.14	5250	2 2 5		
19	73.37	99	3.83	7437	S 0 5 2 1 7 1 . _ M _ - _ - _ . 2 5 A - -	21.5	71
17	82.67	111	3.45	7436	8 0 .		
13	109.07	145	2.70	7435	1 1 2		
11	124.00	164	2.34	7436	1 2 5		
10	142.00	162	2.97	7436	1 4 0		
8.8	160.00	181	2.65	7431	1 6 0		
6.6	211.11	235	2.04	7425	2 1 2		
5.8	240.00	265	1.82	7434	2 5 0		
13	103.90	137	2.91	7433	S 0 5 3 1 1 0 0 _ M _ - _ - _ . 2 5 A - -	25.5	71
12	118.73	156	2.55	7430	1 1 8		
11	130.38	148	3.25	7432	1 3 2		
10	140.51	159	3.03	7430	1 5 0		
8.7	160.26	209	1.89	7427	1 6 0		
7.5	187.76	243	1.61	7427	1 8 0		
7.0	201.10	222	2.16	7430	2 0 0		
6.1	229.81	253	1.90	7427	2 2 5		
5.3	262.58	335	1.16	7424	2 6 5		
4.8	291.75	372	1.04	7419	2 8 0		
4.5	310.18	335	1.44	7424	3 1 5		
3.9	363.40	390	1.24	7414	3 6 0		
2.8	508.21	535	0.90	7400	5 0 0		
11	124.00	173	3.05	11838	S 0 6 2 1 1 2 5 _ M _ - _ - _ . 2 5 A - -	34.5	71
6.5	214.00	252	3.03	11817	2 1 2		
5.8	240.00	280	2.73	11796	2 5 0		
8.2	169.81	234	3.27	11817	S 0 6 3 1 1 6 0 _ M _ - _ - _ . 2 5 A - -	39.5	71
7.6	184.62	253	3.02	11796	1 8 0		
5.3	265.95	360	2.12	11748	2 6 5		
4.7	299.67	404	1.89	11644	2 8 0		
4.3	328.67	374	2.05	11744	3 1 5		
3.9	357.32	404	1.89	11744	3 6 0		
3.5	395.39	530	1.44	11592	4 0 0		
3.1	449.50	599	1.28	11500	4 5 0		
2.7	514.75	569	1.34	11600	5 0 0		
2.4	580.00	637	1.20	11600	5 6 0		
5.6	249.94	354	3.78	29152	S 0 7 3 1 2 6 5 _ M _ - _ - _ . 2 5 A - -	86.5	71
5.1	273.68	386	3.46	29143	2 8 0		
4.4	319.95	422	3.01	28013	3 1 5		
4.1	341.61	449	2.82	26909	3 6 0		
3.7	373.83	522	2.56	26449	4 0 0		
3.3	419.25	584	2.29	29117	4 5 0		
2.8	499.88	651	1.95	29096	5 0 0		
2.6	547.35	710	1.79	29096	5 6 0		
1.9	747.66	953	1.32	29048	8 0 0		
1.7	838.50	1066	1.18	29018	9 0 0		
1.4	1009.20	1375	0.97	28931	S 0 7 4 1 1 0 C _ M _ - _ - _ . 2 5 A - -	90.5	71
1.3	1097.19	1494	0.90	28931	1 1 C		
1.2	1213.28	1632	0.82	28931	1 2 C		
2.6	547.09	760	3.57	41656	S 0 8 4 1 5 6 0 _ M _ - _ - _ . 2 5 A - -	143.5	71
2.2	636.31	883	3.07	41656	6 3 0		
2.0	711.92	986	2.75	41656	7 1 0		
1.8	758.79	1052	2.58	41656	8 0 0		
1.6	899.27	1245	2.18	41656	9 0 0		
1.5	960.14	1328	2.04	41656	1 0 C		
1.3	1083.79	1493	1.90	41656	1 1 C		
1.2	1191.45	1643	1.65	41656	1 2 C		
0.99	1404.96	1932	1.41	41656	1 4 C		

NOTE

Other output speeds are available using 2 and 8 pole motors. Please contact our Application Engineers

S SERIES SELECTION TABLE GEARED MOTORS

0.25 kW
4 POLE

0.25 kW
6 POLE

N2 RPM	i	M2 Nm	Fm	N	Unit Designation	kg	
Output Speed	Ratio	Output Torque	Service Factor	Overhung Load	Column Entry 1 - 20 Spaces to be filled when entering order	Weight of Base Mount unit	Motor Size
0.91	1532.14	2085	1.57	41545	S 0 8 4 1 1 6 C _ M _ _ _ . 2 5 A _ _	143.5	71
0.74	1901.25	2582	1.27	41545	1 8 C		
0.67	2088.45	2826	1.19	41545	2 0 C		
0.62	2241.96	3039	1.08	41545	2 2 C		
0.57	2462.71	3326	1.01	41545	2 5 C		
0.52	2696.62	3637	0.92	41545	2 8 C		
1.5	917.87	1298	3.68	53383	S 0 9 4 1 9 0 0 _ M _ _ _ . 2 5 A _ _	211.5	71
1.4	980.00	1385	3.45	53383	1 0 C		
1.3	1088.78	1533	3.14	53383	1 1 C		
1.2	1216.09	1713	2.79	53383	1 2 C		
0.98	1434.02	2015	2.37	53383	1 4 C		
0.91	1537.95	2137	2.30	53383	1 6 C		
0.73	1908.45	2646	1.86	53383	1 8 C		
0.66	2106.88	2914	1.70	53383	2 0 C		
0.62	2250.46	3113	1.58	53383	2 2 C		
0.56	2484.44	3429	1.44	53383	2 5 C		
0.51	2720.42	3749	1.32	53383	2 8 C		
0.42	3333.96	4578	1.08	53383	3 2 C		
0.37	3774.96	5168	0.95	53383	3 6 C		
105	8.59	18	4.72	2854	S 0 3 2 1 8 . 0 _ M _ _ _ . 2 5 C _ _	15.5	71
78	11.61	24	3.86	2852	1 1 .		
68	13.20	28	3.49	2851	1 2 .		
60	14.95	31	3.20	2850	1 4 .		
55	16.36	30	3.11	2850	1 6 .		
47	19.12	40	2.67	2839	1 8 .		
44	20.61	43	2.54	2838	2 0 .		
41	22.11	40	2.54	2839	2 2 .		
36	25.14	46	2.32	2837	2 5 .		
32	28.48	52	2.13	2835	2 8 .		
27	33.71	70	1.79	2829	3 2 .		
25	36.43	65	1.79	2831	3 6 .		
23	39.26	70	1.70	2829	4 0 .		
20	45.50	93	1.48	2812	4 5 .		
17	53.31	108	1.34	2799	5 0 .		
16	56.19	98	1.33	2812	5 6 .		
14	64.21	111	1.21	2799	6 3 .		
12	74.55	149	1.00	2778	7 1 .		
11	82.83	164	0.9	2773	8 0 .		
10	86.67	147	1.01	2788	9 0 .		
8.9	101.54	170	0.87	2770	1 0 0		
36	25.14	47	3.70	5285	S 0 4 2 1 2 5 . _ M _ _ _ . 2 5 C _ _	18.5	71
32	28.48	53	3.40	5284	2 8 .		
27	33.71	70	2.95	5281	3 2 .		
25	36.43	67	2.86	5283	3 6 .		
23	39.26	71	2.73	5282	4 0 .		
20	45.50	94	2.19	5279	4 5 .		
17	53.31	109	1.88	5277	5 0 .		
16	56.19	100	2.13	5279	5 6 .		
14	64.21	113	1.94	5275	6 3 .		
12	74.55	150	1.35	5271	7 1 .		
11	82.83	166	1.13	5265	8 0 .		
10	86.67	150	1.64	5269	9 0 .		
8.9	101.54	174	1.46	5264	1 0 0		
6.3	142.00	238	1.17	5253	1 4 0		
5.7	157.78	262	1.06	5243	1 6 0		
8.5	105.36	208	0.96	5259	S 0 4 3 1 1 0 0 _ M _ _ _ . 2 5 C _ _	21.5	71
7.5	120.39	237	0.84	5253	1 1 8		
6.9	130.10	216	1.26	5256	1 3 2		
6.4	140.21	233	1.19	5253	1 5 0		
4.5	200.68	326	0.85	5228	2 0 0		
12	73.37	152	2.62	7432	S 0 5 2 1 7 1 . _ M _ _ _ . 2 5 C _ _	21.5	71
11	82.67	170	2.33	7430	8 0 .		
10	90.67	162	2.97	7430	9 0 .		
9.1	98.57	175	2.74	7429	1 0 0		
8.3	109.07	223	1.73	7427	1 1 2		
7.3	124.00	252	1.51	7427	1 2 5		
6.3	142.00	246	1.95	7427	1 4 0		
5.6	160.00	275	1.75	7421	1 6 0		
4.3	211.11	359	1.34	5904	2 1 2		
3.8	240.00	404	1.19	7414	2 5 0		
8.7	103.90	211	1.87	6567	S 0 5 3 1 1 0 0 _ M _ _ _ . 2 5 C _ _	25.5	71
7.6	118.73	240	1.63	6453	1 1 8		
6.9	130.38	225	2.13	6453	1 3 2		
6.4	140.51	242	1.99	6453	1 5 0		

NOTE
Other output speeds are available using 2 and 8 pole motors. Please contact our Application Engineers

S SERIES SELECTION TABLE GEARED MOTORS

0.25 kW

6 POLE

0.37 kW

4 POLE

NOTE

Other output speeds are available using 2 and 8 pole motors. Please contact our Application Engineers

N2 RPM	i	M2 Nm	Fm	N	Unit Designation	kg	
Output Speed	Ratio	Output Torque	Service Factor	Overhung Load	Column Entry 1 - 20 Spaces to be filled when entering order	Weight of Base Mount unit	Motor Size
5.6	160.26	320	1.22	5904	S 0 5 3 1 1 6 0 _ M _ _ _ _ . 2 5 C - -	25.5	71
4.8	187.76	374	1.03	7412	1 8 0		
4.5	201.10	340	1.42	7418	2 0 0		
3.9	229.81	385	1.25	7412	2 2 5		
2.9	310.18	512	0.94	7403	3 1 5		
2.5	363.40	595	0.81	6691	3 6 0		
11	80.94	176	3.9	11834	S 0 6 2 1 8 0 . _ M _ _ _ _ . 2 5 C - -	34.5	71
8.1	110.57	239	2.99	11807	1 1 2		
7.3	124.00	266	1.96	11796	1 2 5		
6.3	143.08	263	2.91	11817	1 4 0		
5.7	156.67	286	2.67	11796	1 6 0		
4.2	214.00	383	2.00	11755	2 1 2		
3.8	240.00	426	1.8	11734	2 5 0		
5.3	169.81	360	2.13	11755	S 0 6 3 1 1 6 0 _ M _ _ _ _ . 2 5 C - -	39.5	71
4.9	184.62	390	1.96	11734	1 8 0		
3.4	265.95	555	1.38	11588	2 6 5		
3.0	299.67	622	1.23	11540	2 8 0		
2.7	328.67	568	1.35	11592	3 1 5		
2.5	357.32	615	1.25	11592	3 6 0		
2.3	395.39	817	0.94	11388	4 0 0		
2.0	449.50	924	0.83	11300	4 5 0		
1.7	514.75	869	0.88	11400	5 0 0		
5.6	159.98	353	3.79	29152	S 0 7 3 1 1 6 0 _ M _ _ _ _ . 2 5 C - -	86.5	71
5.3	170.81	377	3.55	29152	1 8 0		
4.6	194.65	404	3.14	29143	2 0 0		
4.0	226.39	465	2.73	29158	2 2 5		
3.6	249.94	545	2.46	29138	2 6 5		
3.3	273.68	595	2.25	29117	2 8 0		
2.8	319.95	651	1.95	29117	3 1 5		
2.6	341.61	693	1.83	29096	3 6 0		
2.4	373.83	806	1.66	29079	4 0 0		
2.1	419.25	900	1.49	29079	4 5 0		
1.8	499.88	997	1.26	29048	5 0 0		
1.6	547.35	1087	1.16	29018	5 6 0		
1.2	747.66	1473	0.86	28940	8 0 0		
1.6	547.09	1183	2.29	41656	S 0 8 4 1 5 6 0 _ M _ _ _ _ . 2 5 C - -	143.5	71
1.4	636.31	1374	1.98	41656	6 3 0		
1.3	711.92	1534	1.77	41656	7 1 0		
1.2	758.79	1635	1.66	41656	8 0 0		
1.0	899.27	1933	1.40	41656	9 0 0		
0.94	960.14	2061	1.32	41656	1 0 C		
0.83	1083.79	2318	1.23	41656	1 1 C		
0.76	1191.45	2546	1.07	41656	1 2 C		
0.64	1404.96	2989	0.91	41656	1 4 C		
0.59	1532.14	3243	1.01	41545	1 6 C		
0.47	1901.25	4010	0.82	41545	1 8 C		
1.6	558.41	1233	3.88	53383	S 0 9 4 1 5 6 0 _ M _ _ _ _ . 2 5 C - -	211.5	71
1.4	649.47	1432	3.34	53383	6 3 0		
1.2	726.65	1598	2.99	53383	7 1 0		
1.2	774.48	1704	2.80	53383	8 0 0		
0.98	917.87	2015	2.37	53383	9 0 0		
0.92	980.00	2149	2.22	53383	1 0 C		
0.83	1088.78	2379	2.02	53383	1 1 C		
0.74	1216.09	2656	1.80	53383	1 2 C		
0.63	1434.02	3120	1.53	53383	1 4 C		
0.59	1537.95	3321	1.48	53383	1 6 C		
0.47	1908.45	4108	1.20	53383	1 8 C		
0.43	2106.88	4525	1.09	53383	2 0 C		
0.40	2250.46	4828	1.02	53383	2 2 C		
0.36	2484.44	5319	0.93	53383	2 5 C		
0.33	2720.42	5813	0.85	53383	2 8 C		
163	8.59	18	4.49	2852	S 0 3 2 1 8 . 0 _ M _ _ _ _ . 3 7 A - -	15.5	71
121	11.61	24	3.63	2850	1 1 .		
106	13.20	27	3.31	2849	1 2 .		
94	14.95	30	3.03	2849	1 4 .		
86	16.36	30	2.90	2847	1 6 .		
73	19.12	39	2.54	2844	1 8 .		
68	20.61	41	2.41	2844	2 0 .		
63	22.11	39	2.37	2844	2 2 .		
56	25.14	45	2.17	2840	2 5 .		
49	28.48	50	2.00	2840	2 8 .		
42	33.71	67	1.68	2826	3 2 .		
38	36.43	63	1.68	2826	3 6 .		

S SERIES SELECTION TABLE GEARED MOTORS

0.37 kW

4 POLE

N2 RPM	i	M2 Nm	Fm	N	Unit Designation	kg	
Output Speed	Ratio	Output Torque	Service Factor	Overhung Load	Column Entry 1 - 20 Spaces to be filled when entering order	Weight of Base Mount unit	Motor Size
36	39.26	68	1.60	2826	S 0 3 2 1 4 0 . _ M _ _ _ _ . 3 7 A - -	15.5	71
31	45.50	90	1.35	2815	4 5 .		
26	53.31	104	1.21	2805	5 0 .		
25	56.19	96	1.25	2815	5 6 .		
22	64.21	108	1.14	2799	6 3 .		
19	74.55	143	0.99	2780	7 1 .		
17	82.83	159	0.92	2780	8 0 .		
16	86.67	143	0.97	2780	9 0 .		
63	22.11	41	3.78	5286	S 0 4 2 1 2 2 . _ M _ _ _ _ . 3 7 A - -	18.5	71
56	25.14	46	3.47	5284	2 5 .		
49	28.48	52	3.21	5284	2 8 .		
42	33.71	68	2.82	5280	3 2 .		
38	36.43	65	2.69	5282	3 6 .		
36	39.26	70	2.55	5282	4 0 .		
31	45.50	91	2.26	5282	4 5 .		
26	53.31	105	1.97	5274	5 0 .		
25	56.19	98	2.00	5278	5 6 .		
22	64.21	110	1.82	5274	6 3 .		
19	74.55	145	1.41	5266	7 1 .		
17	82.83	161	1.19	5266	8 0 .		
16	86.67	146	1.54	5280	9 0 .		
14	101.54	169	1.38	5270	1 0 0		
10	142.00	232	1.09	5250	1 4 0		
8.9	157.78	255	1.00	5240	1 6 0		
13	105.36	200	1.02	5255	S 0 4 3 1 1 0 0 _ M _ _ _ _ . 3 7 A - -	21.5	71
12	120.39	228	0.89	5249	1 1 8		
11	130.10	210	1.14	5255	1 3 2		
10	140.21	225	1.09	5250	1 5 0		
7.0	200.68	316	0.87	5230	2 0 0		
19	73.37	147	2.59	7434	S 0 5 2 1 7 1 . _ M _ _ _ _ . 3 7 A - -	21.5	71
17	82.67	165	2.33	7432	8 0 .		
15	90.67	159	3.00	7432	9 0 .		
14	98.57	171	2.82	7429	1 0 0		
13	109.07	215	1.82	7432	1 1 2		
11	124.00	243	1.58	7434	1 2 5		
10	142.00	240	2.00	7434	1 4 0		
8.8	160.00	268	1.79	7424	1 6 0		
6.6	211.11	349	1.38	7412	2 1 2		
5.8	240.00	392	1.23	7430	2 5 0		
13	103.90	204	1.96	7427	S 0 5 3 1 1 0 0 _ M _ _ _ _ . 3 7 A - -	25.5	71
12	118.73	232	1.72	7422	1 1 8		
11	130.38	219	2.19	7424	1 3 2		
10	140.51	235	2.05	7422	1 5 0		
8.7	160.26	309	1.28	7416	1 6 0		
7.5	187.76	360	1.09	7416	1 8 0		
7.0	201.10	329	1.46	7422	2 0 0		
6.1	229.81	374	1.29	7416	2 2 5		
4.5	310.18	496	0.97	7410	3 1 5		
3.9	363.40	577	0.84	7390	3 6 0		
17	80.94	171	3.55	11909	S 0 6 2 1 8 0 . _ M _ _ _ _ . 3 7 A - -	34.5	71
13	110.57	230	2.74	11797	1 1 2		
11	124.00	257	2.06	11780	1 2 5		
10	143.08	257	2.97	11780	1 4 0		
8.9	156.67	279	2.74	11780	1 6 0		
6.5	214.00	373	2.05	11741	2 1 2		
5.8	240.00	415	1.84	11701	2 5 0		
8.2	169.81	346	2.21	11741	S 0 6 3 1 1 6 0 _ M _ _ _ _ . 3 7 A -	39.5	71
7.6	184.62	375	2.04	11701	1 8 0		
5.3	265.95	533	1.44	11609	2 6 5		
4.7	299.67	599	1.28	11500	2 8 0		
4.3	328.67	553	1.38	11600	3 1 5		
3.9	357.32	599	1.28	11600	3 6 0		
3.5	395.39	784	0.98	11400	4 0 0		
8.8	159.98	340	3.94	29139	S 0 7 3 1 1 6 0 _ M _ _ _ _ . 3 7 A - -	86.5	71
8.2	170.81	361	3.71	29145	1 8 0		
7.2	194.65	389	3.05	29145	2 0 0		
6.2	226.39	449	2.71	29127	2 2 5		
5.6	249.94	523	2.56	29109	2 6 5		
5.1	273.68	572	2.34	29091	2 8 0		
4.4	319.95	624	2.03	26917	3 1 5		
4.1	341.61	665	1.91	24796	3 6 0		
3.7	373.83	773	1.73	23910	4 0 0		
3.3	419.25	864	1.55	29041	4 5 0		
2.8	499.88	963	1.32	29001	5 0 0		
2.6	547.35	1051	1.21	29001	5 6 0		
1.9	747.66	1411	0.89	28909	8 0 0		
2.6	547.09	1125	2.41	41656	S 0 8 4 1 5 6 0 _ M _ _ _ _ . 3 7 A - -	143.5	71
2.2	636.31	1307	2.08	41656	6 3 0		
2.0	711.92	1460	1.86	41656	7 1 0		
1.8	758.79	1557	1.74	41656	8 0 0		

NOTE

Other output speeds are available using 2 and 8 pole motors. Please contact our Application Engineers

S SERIES SELECTION TABLE GEARED MOTORS

0.37 kW

4 POLE

0.37 kW

6 POLE

NOTE

Other output speeds are available using 2 and 8 pole motors. Please contact our Application Engineers

N2 RPM	i	M2 Nm	Fm	N	Unit Designation	kg	
Output Speed	Ratio	Output Torque	Service Factor	Overhung Load	Column Entry 1 - 20 Spaces to be filled when entering order	Weight of Base Mount unit	Motor Size
1.6	899.27	1842	1.47	41656	S 0 8 4 1 9 0 0 _ M _ _ _ . 3 7 A _ _	143.5	71
1.5	960.14	1966	1.38	41656	1 0 C		
1.3	1083.79	2210	1.29	41656	1 1 C		
1.2	1191.45	2432	1.12	41656	1 2 C		
0.99	1404.96	2860	0.95	41656	1 4 C		
0.91	1532.14	3086	1.06	41545	1 6 C		
0.74	1901.25	3822	0.86	41545	1 8 C		
0.67	2088.45	4183	0.80	41545	2 0 C		
2.2	649.47	1363	3.51	53383	S 0 9 4 1 6 3 0 _ M _ _ _ . 3 7 A _ _	211.5	71
1.9	726.65	1522	3.14	53383	7 1 0		
1.8	774.48	1624	2.94	53383	8 0 0		
1.5	917.87	1921	2.49	53383	9 0 0		
1.4	980.00	2050	2.33	53383	1 0 C		
1.3	1088.78	2268	2.12	53383	1 1 C		
1.2	1216.09	2536	1.88	53383	1 2 C		
0.98	1434.02	2983	1.60	53383	1 4 C		
0.91	1537.95	3163	1.56	53383	1 6 C		
0.73	1908.45	3916	1.26	53383	1 8 C		
0.66	2106.88	4313	1.15	53383	2 0 C		
0.62	2250.46	4608	1.07	53383	2 2 C		
0.56	2484.44	5075	0.98	53383	2 5 C		
0.51	2720.42	5549	0.89	53383	2 8 C		
107	8.59	27	3.26	2849	S 0 3 2 1 8 . 0 _ M _ _ _ . 3 7 C _ _	19.5	80A
79	11.61	36	2.67	2845	1 1 .		
70	13.20	41	2.41	2843	1 2 .		
62	14.95	46	2.21	2841	1 4 .		
56	16.36	44	2.15	2842	1 6 .		
48	19.12	58	1.84	2829	1 8 .		
45	20.61	62	1.75	2827	2 0 .		
42	22.11	59	1.75	2829	2 2 .		
37	25.14	66	1.60	2826	2 5 .		
32	28.48	75	1.47	2822	2 8 .		
27	33.71	101	1.23	2810	3 2 .		
25	36.43	94	1.24	2814	3 6 .		
23	39.26	102	1.18	2810	4 0 .		
20	45.50	134	1.02	2787	4 5 .		
17	53.31	156	0.92	2771	5 0 .		
16	56.19	142	0.92	2787	5 6 .		
14	64.21	161	0.84	2771	6 3 .		
62	14.95	47	3.68	5283	S 0 4 2 1 1 4 . _ M _ _ _ . 3 7 C _ _	22.5	80A
56	16.36	45	3.44	5283	1 6 .		
48	19.12	59	3.06	5282	1 8 .		
45	20.61	63	2.93	5280	2 0 .		
42	22.11	60	2.80	5280	2 2 .		
37	25.14	68	2.55	5280	2 5 .		
32	28.48	77	2.35	5279	2 8 .		
27	33.71	102	2.04	5273	3 2 .		
25	36.43	97	1.98	5277	3 6 .		
23	39.26	104	1.88	5274	4 0 .		
20	45.50	136	1.52	5270	4 5 .		
17	53.31	159	1.30	5266	5 0 .		
16	56.19	145	1.47	5270	5 6 .		
14	64.21	164	1.34	5262	6 3 .		
12	74.55	218	0.93	5255	7 1 .		
11	86.67	217	1.13	5250	9 0 .		
9.1	101.54	252	1.01	5240	1 0 0		
6.5	142.00	345	0.81	5220	1 4 0		
7.1	130.10	313	0.87	5226	S 0 4 3 1 1 3 2 _ M _ _ _ . 3 7 C _ _	25.5	80A
6.6	140.21	337	0.82	5220	1 5 0		
28	32.55	101	3.81	7440	S 0 5 2 1 3 2 . _ M _ _ _ . 3 7 C _ _	25.5	80A
23	40.74	111	3.76	7440	4 0 .		
20	46.84	143	2.82	7440	4 5 .		
18	50.93	156	2.59	7440	5 0 .		
17	55.45	149	3.00	7440	5 6 .		
15	63.00	167	2.75	7440	6 3 .		
13	73.37	220	1.81	7424	7 1 .		
11	82.67	247	1.61	7422	8 0 .		
10	90.67	235	2.05	7422	9 0 .		
9.3	98.57	254	1.90	7419	1 0 0		
8.4	109.07	324	1.20	7416	1 1 2		
7.4	124.00	365	1.04	7416	1 2 5		
6.5	142.00	357	1.35	7416	1 4 0		
5.8	160.00	399	1.21	7404	1 6 0		
4.4	211.11	519	0.93	4487	2 1 2		
3.8	240.00	585	0.82	7390	2 5 0		

S SERIES SELECTION TABLE GEARED MOTORS

0.37 kW

6 POLE

N2 RPM	i	M2 Nm	Fm	N	Unit Designation	kg	
Output Speed	Ratio	Output Torque	Service Factor	Overhung Load	Column Entry 1 - 20 Spaces to be filled when entering order	Weight of Base Mount unit	Motor Size
8.9	103.90	306	1.29	5761	S 0 5 3 1 1 0 0 _ M _ _ _ _ . 3 7 C - -	29.5	80A
7.7	118.73	348	1.13	5542	1 1 8		
7.1	130.38	327	1.47	5542	1 3 2		
6.5	140.51	350	1.38	5542	1 5 0		
5.7	160.26	464	0.84	4487	1 6 0		
4.6	201.10	492	0.98	7399	2 0 0		
4.0	229.81	558	0.86	7387	2 2 5		
12	73.92	236	3.24	11791	S 0 6 2 1 7 1 . _ M _ _ _ _ . 3 7 C - -	37.5	80A
11	80.94	256	2.69	11773	8 0 .		
10	91.58	252	3.03	11873	9 0 .		
9.4	97.78	268	2.85	11773	1 0 0		
8.3	110.57	346	2.06	11721	1 1 2		
7.4	124.00	386	1.35	11701	1 2 5		
6.4	143.08	381	2.01	11741	1 4 0		
5.9	156.67	415	1.84	11701	1 6 0		
4.3	214.00	554	1.38	11622	2 1 2		
3.8	240.00	617	1.24	11582	2 5 0		
8.9	103.86	324	2.36	11800	S 0 6 3 1 1 0 0 _ M _ _ _ _ . 3 7 C - -	43.5	80A
7.8	117.99	366	2.09	11700	1 1 8		
7.1	130.00	345	2.22	11800	1 3 2		
6.2	147.69	389	1.97	11700	1 5 0		
5.4	169.81	521	1.47	11622	1 6 0		
5.0	184.62	565	1.35	11582	1 8 0		
4.6	201.02	519	1.47	11600	2 0 0		
4.0	228.38	585	1.31	11600	2 2 5		
3.5	265.95	803	0.95	11393	2 6 5		
3.1	299.67	901	0.85	11300	2 8 0		
2.8	328.67	823	0.93	11400	3 1 5		
2.6	357.32	890	0.86	11400	3 6 0		
9.2	99.79	312	3.65	29200	S 0 7 2 1 1 0 0 _ M _ _ _ _ . 3 7 C - -	80.5	80A
8.8	104.32	339	3.24	29200	1 1 2		
7.9	115.92	375	2.93	29200	1 2 5		
6.7	138.00	425	2.82	29200	1 4 0		
6.1	151.12	461	2.64	29200	1 6 0		
4.4	208.65	627	2.03	29200	2 1 2		
4.0	231.83	693	1.83	29200	2 5 0		
8.1	113.20	366	3.65	29139	S 0 7 3 1 1 1 8 _ M _ _ _ _ . 3 7 C - -	89.5	80A
7.4	125.04	379	3.11	29200	1 3 2		
6.5	141.75	432	2.80	29200	1 5 0		
5.8	159.98	512	2.62	29109	1 6 0		
5.4	170.81	546	2.45	29109	1 8 0		
4.7	194.65	585	2.17	29091	2 0 0		
4.1	226.39	673	1.89	29120	2 2 5		
3.7	249.94	789	1.70	29080	2 6 5		
3.4	273.68	862	1.55	29041	2 8 0		
2.9	319.95	942	1.35	29041	3 1 5		
2.7	341.61	1004	1.26	29001	3 6 0		
2.5	373.83	1167	1.15	28967	4 0 0		
2.2	419.25	1303	1.03	28967	4 5 0		
1.8	499.88	1443	0.87	28909	5 0 0		
1.7	547.35	1574	0.80	28851	5 6 0		
3.9	235.77	712	3.68	41900	S 0 8 2 1 2 5 0 _ M _ _ _ _ . 3 7 C - -	130.5	80A
1.7	547.09	1713	1.58	41656	S 0 8 4 1 5 6 0 _ M _ _ _ _ . 3 7 C - -	146.5	80A
1.4	636.31	1990	1.36	41656	6 3 0		
1.3	711.92	2221	1.22	41656	7 1 0		
1.2	758.79	2368	1.15	41656	8 0 0		
1.0	899.27	2798	0.97	41656	9 0 0		
0.96	960.14	2984	0.91	41656	1 0 C		
0.85	1083.79	3357	0.85	41656	1 1 C		
1.6	558.41	1785	2.68	53383	S 0 9 4 1 5 6 0 _ M _ _ _ _ . 3 7 C - -	214.5	80A
1.4	649.47	2073	2.31	53383	6 3 0		
1.3	726.65	2314	2.07	53383	7 1 0		
1.2	774.48	2468	1.94	53383	8 0 0		
1.0	917.87	2917	1.64	53383	9 0 0		
0.94	980.00	3112	1.54	53383	1 0 C		
0.84	1088.78	3445	1.40	53383	1 1 C		
0.76	1216.09	3846	1.24	53383	1 2 C		
0.64	1434.02	4518	1.06	53383	1 4 C		
0.60	1537.95	4809	1.02	53383	1 6 C		
0.48	1908.45	5947	0.83	53383	1 8 C		

NOTE

Other output speeds are available using 2 and 8 pole motors. Please contact our Application Engineers

S SERIES SELECTION TABLE GEARED MOTORS

0.55 kW
4 POLE

N2 RPM	i	M2 Nm	Fm	N	Unit Designation	kg	
Output Speed	Ratio	Output Torque	Service Factor	Overhung Load	Column Entry 1 - 20 Spaces to be filled when entering order	Weight of Base Mount unit	Motor Size
165	8.59	26	3.06	2847	S 0 3 2 1 8 . 0 _ M _ _ _ . 5 5 A - -	19.5	80A
122	11.61	35	2.47	2844	1 1 .		
108	13.20	39	2.26	2841	1 2 .		
95	14.95	45	2.07	2841	1 4 .		
87	16.36	44	1.98	2838	1 6 .		
74	19.12	57	1.73	2833	1 8 .		
69	20.61	61	1.64	2833	2 0 .		
64	22.11	58	1.62	2833	2 2 .		
56	25.14	66	1.48	2825	2 5 .		
50	28.48	74	1.36	2825	2 8 .		
42	33.71	98	1.15	2809	3 2 .		
39	36.43	93	1.15	2809	3 6 .		
36	39.26	100	1.09	2809	4 0 .		
31	45.50	132	0.92	2790	4 5 .		
27	53.31	153	0.83	2780	5 0 .		
25	56.19	140	0.85	2790	5 6 .		
108	13.20	40	3.76	5285	S 0 4 2 1 1 2 . _ M _ _ _ . 5 5 A - -	22.5	80A
95	14.95	46	3.45	5283	1 4 .		
87	16.36	45	3.17	5283	1 6 .		
74	19.12	58	2.88	5283	1 8 .		
69	20.61	62	2.74	5283	2 0 .		
64	22.11	60	2.58	5283	2 2 .		
56	25.14	67	2.37	5280	2 5 .		
50	28.48	76	2.19	5280	2 8 .		
42	33.71	99	1.92	5274	3 2 .		
39	36.43	95	1.83	5276	3 6 .		
36	39.26	102	1.74	5276	4 0 .		
31	45.50	133	1.54	5276	4 5 .		
27	53.31	155	1.35	5262	5 0 .		
25	56.19	143	1.36	5269	5 6 .		
22	64.21	162	1.24	5262	6 3 .		
19	74.55	213	0.97	5250	7 1 .		
17	82.83	236	0.81	5250	8 0 .		
44	32.55	99	3.44	7440	S 0 5 2 1 3 2 . _ M _ _ _ . 5 5 A - -	25.5	80A
40	35.86	98	3.85	7440	3 6 .		
35	40.74	110	3.51	7440	4 0 .		
30	46.84	141	2.71	7440	4 5 .		
28	50.93	152	2.56	7440	5 0 .		
26	55.45	147	2.81	7440	5 6 .		
23	63.00	165	2.58	7440	6 3 .		
19	73.37	215	1.76	7431	7 1 .		
17	82.67	241	1.59	7426	8 0 .		
16	90.67	233	2.05	7426	9 0 .		
14	98.57	250	1.92	7422	1 0 0		
13	109.07	316	1.24	7426	1 1 2		
11	124.00	357	1.08	7430	1 2 5		
10	142.00	352	1.37	7430	1 4 0		
8.9	160.00	394	1.22	7412	1 6 0		
6.7	211.11	511	0.94	7392	2 1 2		
14	103.90	299	1.34	7418	S 0 5 3 1 1 0 0 _ M _ _ _ . 5 5 A - -	29.5	80A
12	118.73	340	1.17	7409	1 1 8		
11	130.38	321	1.50	7413	1 3 2		
10	140.51	345	1.40	7409	1 5 0		
8.9	160.26	453	0.87	7399	1 6 0		
7.1	201.10	483	1.00	7410	2 0 0		
6.2	229.81	549	0.88	7400	2 2 5		
22	64.80	180	3.99	11896	S 0 6 2 1 6 3 . _ M _ _ _ . 5 5 A - -	37.5	80A
19	73.92	230	3.31	11844	7 1 .		
18	80.94	251	2.42	11844	8 0 .		
16	91.58	250	3.06	11844	9 0 .		
15	97.78	265	2.88	11844	1 0 0		
13	110.57	338	1.87	11724	1 1 2		
11	124.00	376	1.41	11695	1 2 5		
10	143.08	377	2.03	11695	1 4 0		
9.1	156.67	409	1.87	11695	1 6 0		
6.6	214.00	548	1.40	11626	2 1 2		
5.9	240.00	609	1.26	11558	2 5 0		
14	103.86	316	2.42	11800	S 0 6 3 1 1 0 0 _ M _ _ _ . 5 5 A - -	43.5	80A
12	117.99	358	2.14	11700	1 1 8		
11	130.00	341	2.24	11800	1 3 2		
10	147.69	384	1.99	11700	1 5 0		
8.4	169.81	508	1.51	11626	1 6 0		
7.7	184.62	550	1.39	11558	1 8 0		
7.1	201.02	512	1.50	11600	2 0 0		
6.2	228.38	577	1.33	11600	2 2 5		
5.3	265.95	782	0.98	11400	2 6 5		
19	75.56	243	3.85	29200	S 0 7 2 1 8 0 . _ M _ _ _ . 5 5 A - -	80.5	80A
16	88.26	271	3.79	29200	9 0 .		
14	99.79	303	3.45	29200	1 0 0		
14	104.32	330	2.94	29200	1 1 2		
12	115.92	366	2.64	29200	1 2 5		
10	138.00	413	2.71	29200	1 4 0		
9.4	151.12	454	2.51	29200	1 6 0		

NOTE

Other output speeds are available using 2 and 8 pole motors. Please contact our Application Engineers

S SERIES SELECTION TABLE GEARED MOTORS

0.55 kW
4 POLE

N2 RPM	i	M2 Nm	Fm	N	Unit Designation	kg			
Output Speed	Ratio	Output Torque	Service Factor	Overhung Load	Column Entry 1 - 20 Spaces to be filled when entering order	Weight of Base Mount unit	Motor Size		
6.8	208.65	612	1.96	29200	S 0 7 2 1 2 1 2 _ M _ _ _ . 5 5 A -	80.5	80A		
6.1	231.83	678	1.80	29200	2 5 0				
13	113.20	356	3.76	29125	S 0 7 3 1 1 1 8 _ M _ _ _ . 5 5 A -	89.5	80A		
11	125.04	372	2.96	29200	1 3 2				
10	141.75	416	2.69	29200	1 5 0				
8.9	159.98	498	2.69	29096	1 6 0				
8.3	170.81	529	2.53	29106	1 8 0				
7.3	194.65	571	2.08	29106	2 0 0				
6.3	226.39	658	1.85	29075	2 2 5				
5.7	249.94	767	1.74	29044	2 6 5				
5.2	273.68	838	1.60	29013	2 8 0				
4.4	319.95	915	1.39	25273	3 1 5				
4.2	341.61	975	1.30	21625	3 6 0				
3.8	373.83	1133	1.18	20101	4 0 0				
3.4	419.25	1266	1.06	28926	4 5 0				
2.8	499.88	1412	0.90	28858	5 0 0				
2.6	547.35	1540	0.82	28858	5 6 0				
6.0	235.77	699	3.61	41900	S 0 8 2 1 2 5 0 _ M _ _ _ . 5 5 A -	130.5	80A		
2.6	547.09	1649	1.65	41656	S 0 8 4 1 5 6 0 _ M _ _ _ . 5 5 A -				
2.2	636.31	1916	1.42	41656	6 3 0	146.5	80A		
2.0	711.92	2140	1.27	41656	7 1 0				
1.9	758.79	2282	1.19	41656	8 0 0				
1.6	899.27	2700	1.01	41656	9 0 0				
1.5	960.14	2881	0.94	41656	1 0 C				
1.3	1083.79	3239	0.88	41656	1 1 C				
2.5	558.41	1719	2.78	53383	S 0 9 4 1 5 6 0 _ M _ _ _ . 5 5 A -			214.5	80A
2.2	649.47	1998	2.39	53383	6 3 0				
2.0	726.65	2231	2.14	53383	7 1 0				
1.8	774.48	2380	2.01	53383	8 0 0				
1.5	917.87	2816	1.70	53383	9 0 0				
1.4	980.00	3004	1.59	53383	1 0 C				
1.3	1088.78	3325	1.45	53383	1 1 C				
1.2	1216.09	3717	1.29	53383	1 2 C				
0.99	1434.02	4371	1.09	53383	1 4 C				
0.92	1537.95	4636	1.06	53383	1 6 C				
0.74	1908.45	5740	0.86	53383	1 8 C				
107	8.59	40	2.20	2841	S 0 3 2 1 8 . 0 _ M _ _ _ . 5 5 C -	21	80B		
79	11.61	53	1.79	2835	1 1 .				
70	13.20	61	1.62	2831	1 2 .				
62	14.95	68	1.49	2828	1 4 .				
56	16.36	66	1.44	2829	1 6 .				
48	19.12	87	1.24	2814	1 8 .				
45	20.61	93	1.18	2810	2 0 .				
42	22.11	88	1.18	2814	2 2 .				
37	25.14	99	1.08	2809	2 5 .				
32	28.48	112	0.99	2802	2 8 .				
27	33.71	150	0.83	2781	3 2 .				
25	36.43	140	0.83	2788	3 6 .				
107	8.59	41	3.64	5285	S 0 4 2 1 8 . 0 _ M _ _ _ . 5 5 C -			24	80B
79	11.61	55	2.96	5281	1 1 .				
70	13.20	61	2.70	5279	1 2 .				
62	14.95	69	2.47	5279	1 4 .				
56	16.36	68	2.32	5279	1 6 .				
48	19.12	89	2.06	5277	1 8 .				
45	20.61	94	1.97	5274	2 0 .				
42	22.11	90	1.88	5274	2 2 .				
37	25.14	101	1.72	5274	2 5 .				
32	28.48	114	1.58	5271	2 8 .				
27	33.71	152	1.37	5261	3 2 .				
25	36.43	144	1.33	5268	3 6 .				
23	39.26	154	1.27	5263	4 0 .				
20	45.50	203	1.02	5255	4 5 .				
17	53.31	236	0.87	5249	5 0 .				
16	56.19	215	0.99	5255	5 6 .				
14	64.21	244	0.90	5242	6 3 .				
50	18.53	87	3.69	7439	S 0 5 2 1 1 8 . _ M _ _ _ . 5 5 C -	27	80B		
44	21.05	98	3.42	7438	2 0 .				
41	22.56	95	3.89	7439	2 2 .				
37	24.86	104	3.62	7438	2 5 .				
33	28.24	118	3.29	7437	2 8 .				
28	32.55	151	2.56	7435	3 2 .				
26	35.86	147	2.77	7435	3 6 .				

NOTE

Other output speeds are available using 2 and 8 pole motors. Please contact our Application Engineers

S SERIES SELECTION TABLE GEARED MOTORS

0.55 kW

6 POLE

N2 RPM	i	M2 Nm	Fm	N	Unit Designation	kg	
Output Speed	Ratio	Output Torque	Service Factor	Overhung Load	Column Entry 1 - 20 Spaces to be filled when entering order	Weight of Base Mount unit	Motor Size
23	40.74	166	2.53	7434	S 0 5 2 1 4 0 . _ M _ - _ - . 5 5 C - -	27	80B
20	46.84	213	1.90	7432	4 5 .		
18	50.93	232	1.74	7430	5 0 .		
17	55.45	222	2.02	7432	5 6 .		
15	63.00	249	1.85	7430	6 3 .		
13	73.37	328	1.22	7413	7 1 .		
11	82.67	367	1.08	7409	8 0 .		
10	90.67	349	1.38	7409	9 0 .		
9.3	98.57	377	1.28	7404	1 0 0		
8.4	109.07	481	0.81	7399	1 1 2		
6.5	142.00	530	0.91	7400	1 4 0		
5.8	160.00	593	0.81	7378	1 6 0		
8.9	103.90	455	0.87	4552	S 0 5 3 1 1 0 0 _ M _ - _ - . 5 5 C - -	31	80B
7.1	130.38	486	0.99	4175	1 3 2		
6.5	140.51	520	0.93	4175	1 5 0		
19	47.32	228	3.35	11865	S 0 6 2 1 4 5 . _ M _ - _ - . 5 5 C - -	39	80B
18	50.52	242	3.15	11855	5 0 .		
17	55.71	236	3.19	11855	5 6 .		
14	64.80	271	2.82	11834	6 3 .		
12	73.92	351	2.18	11713	7 1 .		
11	80.94	380	1.81	11681	8 0 .		
10	91.58	375	2.04	11781	9 0 .		
9.4	97.78	399	1.92	11681	1 0 0		
8.3	110.57	515	1.39	11592	1 1 2		
7.4	124.00	573	0.91	11558	1 2 5		
6.4	143.08	567	1.35	11626	1 4 0		
5.9	156.67	617	1.24	11558	1 6 0		
4.3	214.00	824	0.93	11422	2 1 2		
3.8	240.00	917	0.83	11353	2 5 0		
8.9	103.86	482	1.59	11676	S 0 6 3 1 1 0 0 _ M _ - _ - . 5 5 C - -	45	80B
7.8	117.99	545	1.40	11576	1 1 8		
7.1	130.00	513	1.49	11676	1 3 2		
6.2	147.69	578	1.32	11576	1 5 0		
5.4	169.81	775	0.99	11422	1 6 0		
5.0	184.62	840	0.91	11353	1 8 0		
4.6	201.02	772	0.99	11457	2 0 0		
4.0	228.38	870	0.88	11410	2 2 5		
18	49.90	248	3.85	29180	S 0 7 2 1 5 0 . _ M _ - _ - . 5 5 C - -	82	80B
17	53.62	254	3.97	29179	5 6 .		
15	61.62	292	3.55	29179	6 3 .		
13	69.00	338	3.10	29172	7 1 .		
12	75.56	370	2.86	29165	8 0 .		
10	88.26	410	2.70	29168	9 0 .		
9.2	99.79	464	2.46	29168	1 0 0		
8.8	104.32	505	2.18	29168	1 1 2		
7.9	115.92	558	1.97	29152	1 2 5		
6.7	138.00	631	1.90	29150	1 4 0		
6.1	151.12	686	1.78	29150	1 6 0		
4.4	208.65	932	1.36	29105	2 1 2		
4.0	231.83	1030	1.23	29057	2 5 0		
9.5	97.33	471	2.84	29117	S 0 7 3 1 1 0 0 _ M _ - _ - . 5 5 C - -	91	80B
8.1	113.20	545	2.46	29096	1 1 8		
7.4	125.04	564	2.09	29150	1 3 2		
6.5	141.75	642	1.88	29136	1 5 0		
5.8	159.98	761	1.76	29044	1 6 0		
5.4	170.81	812	1.65	29044	1 8 0		
4.7	194.65	870	1.46	29013	2 0 0		
4.1	226.39	1001	1.27	29063	2 2 5		
3.7	249.94	1174	1.14	28995	2 6 5		
3.4	273.68	1281	1.05	28926	2 8 0		
2.9	319.95	1401	0.91	28926	3 1 5		
2.7	341.61	1493	0.85	28858	3 6 0		
6.6	139.29	644	3.85	41880	S 0 8 2 1 1 4 0 _ M _ - _ - . 5 5 C - -	132	80B
6.0	153.00	705	3.57	41880	1 6 0		
4.5	204.75	931	2.82	41868	2 1 2		
3.9	235.77	1058	2.47	41868	2 5 0		
1.7	547.09	2547	1.07	41656	S 0 8 4 1 5 6 0 _ M _ - _ - . 5 5 C - -	148	80B
1.4	636.31	2958	0.92	41656	6 3 0		
1.3	711.92	3301	0.82	41656	7 1 0		
1.6	558.41	2654	1.80	53383	S 0 9 4 1 5 6 0 _ M _ - _ - . 5 5 C - -	216	80B
1.4	649.47	3082	1.55	53383	6 3 0		
1.3	726.65	3441	1.39	53383	7 1 0		
1.2	774.48	3668	1.30	53383	8 0 0		
1.0	917.87	4337	1.10	53383	9 0 0		
0.94	980.00	4626	1.03	53383	1 0 C		
0.84	1088.78	5121	0.94	53383	1 1 C		
0.76	1216.09	5717	0.84	53383	1 2 C		
1.9	495.31	2376	3.57	87299	S 1 0 4 1 5 0 0 _ M _ - _ - . 5 5 C - -	334	80B
1.7	544.84	2611	3.24	87299	5 6 0		

NOTE

Other output speeds are available using 2 and 8 pole motors. Please contact our Application Engineers

S SERIES SELECTION TABLE GEARED MOTORS

0.55 kW
6 POLE

0.75 kW
4 POLE

N2 RPM	i	M2 Nm	Fm	N	Unit Designation	kg	
Output Speed	Ratio	Output Torque	Service Factor	Overhung Load	Column Entry 1 - 20 Spaces to be filled when entering order	Weight of Base Mount unit	Motor Size
1.5	626.07	2997	2.83	87299	S 1 0 4 1 6 3 0 _ M _ _ _ _ . 5 5 C _ _	334	80B
1.3	709.95	3391	2.50	87299	7 1 0		
1.2	783.06	3741	2.27	87299	8 0 0		
1.0	896.77	4277	1.98	87299	9 0 0		
0.91	1013.93	4827	1.76	87299	1 0 C		
0.82	1126.71	5342	1.55	87375	1 1 C		
0.78	1175.54	5582	1.52	87299	1 2 C		
0.66	1402.11	6635	1.28	87299	1 4 C		
0.57	1606.71	7534	1.14	87299	1 6 C		
0.49	1862.80	8716	0.98	87299	1 8 C		
0.43	2146.36	9991	0.86	87299	2 0 C		
0.41	2221.83	10366	0.83	87299	2 2 C		
165	8.59	36	2.24	2841	S 0 3 2 1 8 . 0 _ M _ _ _ _ . 7 5 A _ _		
122	11.61	48	1.81	2837	1 1 .		
107	13.20	54	1.65	2832	1 2 .		
95	14.95	62	1.51	2832	1 4 .		
86	16.36	60	1.44	2827	1 6 .		
74	19.12	78	1.27	2821	1 8 .		
69	20.61	84	1.20	2821	2 0 .		
64	22.11	80	1.18	2821	2 2 .		
56	25.14	90	1.08	2810	2 5 .		
50	28.48	101	1.00	2810	2 8 .		
42	33.71	134	0.84	2790	3 2 .		
39	36.43	127	0.84	2790	3 6 .		
165	8.59	37	3.70	5287	S 0 4 2 1 8 . 0 _ M _ _ _ _ . 7 5 A _ _	22.5	80A
122	11.61	49	3.01	5283	1 1 .		
107	13.20	56	2.75	5283	1 2 .		
95	14.95	62	2.52	5280	1 4 .		
86	16.36	62	2.32	5280	1 6 .		
74	19.12	79	2.11	5280	1 8 .		
69	20.61	85	2.00	5280	2 0 .		
64	22.11	82	1.89	5280	2 2 .		
56	25.14	93	1.73	5276	2 5 .		
50	28.48	104	1.60	5276	2 8 .		
42	33.71	136	1.41	5267	3 2 .		
39	36.43	131	1.34	5270	3 6 .		
36	39.26	140	1.27	5270	4 0 .		
31	45.50	182	1.13	5270	4 5 .		
27	53.31	212	0.98	5250	5 0 .		
25	56.19	196	1.00	5260	5 6 .		
22	64.21	222	0.91	5250	6 3 .		
76	18.53	79	3.57	7440	S 0 5 2 1 1 8 . _ M _ _ _ _ . 7 5 A _ _	25.5	80A
67	21.05	89	3.30	7439	2 0 .		
63	22.56	87	3.94	7439	2 2 .		
57	24.86	95	3.68	7439	2 5 .		
50	28.24	107	3.37	7438	2 8 .		
43	32.55	135	2.51	7437	3 2 .		
39	35.86	134	2.81	7437	3 6 .		
35	40.74	151	2.56	7437	4 0 .		
30	46.84	193	1.98	7437	4 5 .		
28	50.93	208	1.87	7435	5 0 .		
26	55.45	201	2.06	7435	5 6 .		
22	63.00	226	1.89	7433	6 3 .		
19	73.37	295	1.29	7427	7 1 .		
17	82.67	330	1.16	7420	8 0 .		
16	90.67	319	1.50	7420	9 0 .		
14	98.57	343	1.41	7414	1 0 0		
13	109.07	432	0.91	7420	1 1 2		
8.8	160.00	539	0.89	7400	1 6 0		
14	103.90	409	0.98	7407	S 0 5 3 1 1 0 0 _ M _ _ _ _ . 7 5 A _ _	29.5	80A
12	118.73	465	0.86	7395	1 1 8		
11	130.38	440	1.09	7401	1 3 2		
10	140.51	472	1.02	7395	1 5 0		
30	47.32	205	3.38	11868	S 0 6 2 1 4 5 . _ M _ _ _ _ . 7 5 A _ _	37.5	80A
28	50.52	218	3.24	11848	5 0 .		
25	55.71	215	3.24	11878	5 6 .		
22	64.80	247	2.91	11848	6 3 .		
19	73.92	314	2.42	11771	7 1 .		
17	80.94	344	1.77	11771	8 0 .		
15	91.58	342	2.24	11771	9 0 .		
14	97.78	363	2.11	11771	1 0 0		
13	110.57	462	1.37	11642	1 1 2		
11	124.00	515	1.03	11600	1 2 5		
10	143.08	516	1.48	11600	1 4 0		

NOTE

Other output speeds are available using 2 and 8 pole motors. Please contact our Application Engineers

S SERIES SELECTION TABLE GEARED MOTORS

0.75 kW
4 POLE

N2 RPM	i	M2 Nm	Fm	N	Unit Designation	kg	
Output Speed	Ratio	Output Torque	Service Factor	Overhung Load	Column Entry 1 - 20 Spaces to be filled when entering order	Weight of Base Mount unit	Motor Size
9	156.67	560	1.37	11600	S 0 6 2 1 1 6 0 _ M _ _ _ . 7 5 A - -	37.5	80A
6.6	214.00	749	1.02	11500	2 1 2		
5.9	240.00	833	0.92	11400	2 5 0		
14	103.86	432	1.77	11690	S 0 6 3 1 1 0 0 _ M _ _ _ . 7 5 A - -	43.5	80A
12	117.99	490	1.56	11590	1 1 8		
11	130.00	467	1.64	11690	1 3 2		
10	147.69	525	1.46	11627	1 5 0		
8.3	169.81	695	1.10	11500	1 6 0		
7.7	184.62	753	1.02	11400	1 8 0		
7.0	201.02	700	1.09	11500	2 0 0		
6.2	228.38	790	0.97	11400	2 2 5		
28	49.90	222	3.96	29187	S 0 7 2 1 5 0 . _ M _ _ _ . 7 5 A - -	80.5	80A
23	61.62	262	3.70	29182	6 3 .		
21	69.00	304	3.04	29182	7 1 .		
19	75.56	333	2.81	29176	8 0 .		
16	88.26	371	2.77	29175	9 0 .		
14	99.79	415	2.52	29175	1 0 0		
14	104.32	452	2.15	29175	1 1 2		
12	115.92	502	1.93	29163	1 2 5		
10	138.00	566	1.98	29157	1 4 0		
9.4	151.12	621	1.83	29157	1 6 0		
6.8	208.65	838	1.43	29127	2 1 2		
6.1	231.83	928	1.31	29090	2 5 0		
15	97.33	422	3.17	29134	S 0 7 3 1 1 0 0 _ M _ _ _ . 7 5 A - -	89.5	80A
13	113.20	488	2.75	29090	1 1 8		
11	125.04	509	2.16	29159	1 3 2		
10	141.75	570	1.96	29163	1 5 0		
8.8	159.98	682	1.96	29048	1 6 0		
8.3	170.81	725	1.85	29063	1 8 0		
7.3	194.65	781	1.52	29063	2 0 0		
6.3	226.39	901	1.35	29017	2 2 5		
5.7	249.94	1050	1.28	28971	2 6 5		
5.2	273.68	1148	1.17	28926	2 8 0		
4.4	319.95	1252	1.01	23447	3 1 5		
4.1	341.61	1335	0.95	18101	3 6 0		
3.8	373.83	1550	0.86	15869	4 0 0		
10	139.29	578	3.99	41882	S 0 8 2 1 1 4 0 _ M _ _ _ . 7 5 A - -	130.5	80A
9.2	153.00	633	3.71	41883	1 6 0		
6.9	204.75	836	2.95	41867	2 1 2		
6.0	235.77	957	2.64	41875	2 5 0		
2.6	547.09	2256	1.20	41656	S 0 8 4 1 5 6 0 _ M _ _ _ . 7 5 A - -	146.5	80A
2.2	636.31	2622	1.04	41656	6 3 0		
2.0	711.92	2929	0.93	41656	7 1 0		
1.9	758.79	3123	0.87	41656	8 0 0		
2.5	558.41	2353	2.03	53383	S 0 9 4 1 5 6 0 _ M _ _ _ . 7 5 A - -	214.5	80A
2.2	649.47	2734	1.75	53383	6 3 0		
1.9	726.65	3054	1.57	53383	7 1 0		
1.8	774.48	3257	1.47	53383	8 0 0		
1.5	917.87	3853	1.24	53383	9 0 0		
1.4	980.00	4111	1.16	53383	1 0 C		
1.3	1088.78	4550	1.06	53383	1 1 C		
1.2	1216.09	5087	0.94	53383	1 2 C		
2.6	544.84	2314	3.66	87299	S 1 0 4 1 5 6 0 _ M _ _ _ . 7 5 A - -	332.5	80A
2.3	626.07	2657	3.19	87299	6 3 0		
2.0	709.95	3008	2.82	87299	7 1 0		
1.8	783.06	3319	2.55	87299	8 0 0		
1.6	896.77	3797	2.23	87299	9 0 0		
1.4	1013.93	4288	1.98	87299	1 0 C		
1.3	1126.71	4744	1.75	87375	1 1 C		
1.2	1175.54	4962	1.71	87299	1 2 C		
1.0	1402.11	5904	1.44	87299	1 4 C		
0.88	1606.71	6682	1.28	87299	1 6 C		
0.76	1862.80	7737	1.11	87299	1 8 C		
0.66	2146.36	8864	0.97	87299	2 0 C		
0.64	2221.83	9211	0.93	87299	2 2 C		
0.55	2560.05	10553	0.81	87299	2 5 C		

NOTE

Other output speeds are available using 2 and 8 pole motors. Please contact our Application Engineers

S SERIES SELECTION TABLE GEARED MOTORS

0.75 kW
6 POLE

N2 RPM	i	M2 Nm	Fm	N	Unit Designation	kg	
Output Speed	Ratio	Output Torque	Service Factor	Overhung Load	Column Entry 1 - 20 Spaces to be filled when entering order	Weight of Base Mount unit	Motor Size
107	8.59	55	1.61	2832	S 0 3 2 1 8 . 0 _ M _ _ _ _ . 7 5 C _ _	24.5	90S
79	11.61	73	1.32	2823	1 1 .		
70	13.20	83	1.19	2818	1 2 .		
62	14.95	93	1.09	2814	1 4 .		
56	16.36	90	1.06	2815	1 6 .		
48	19.12	118	0.91	2798	S 0 3 2 1 1 8 . _ M _ _ _ _ . 7 5 C _ _	24.5	90S
45	20.61	127	0.86	2792	2 0 .		
42	22.11	120	0.87	2798	2 2 .		
107	8.59	56	2.67	5283	S 0 4 2 1 8 . 0 _ M _ _ _ _ . 7 5 C _ _	26.5	90S
79	11.61	75	2.17	5277	1 1 .		
70	13.20	84	1.98	5274	1 2 .		
62	14.95	95	1.81	5274	1 4 .		
56	16.36	92	1.70	5274	1 6 .		
48	19.12	121	1.51	5271	1 8 .		
45	20.61	129	1.44	5267	2 0 .		
42	22.11	123	1.38	5267	2 2 .		
37	25.14	138	1.26	5267	2 5 .		
32	28.48	156	1.16	5262	2 8 .		
27	33.71	207	1.01	5248	3 2 .		
25	36.43	196	0.97	5257	3 6 .		
23	39.26	210	0.93	5251	4 0 .		
79	11.66	76	3.60	7440	S 0 5 2 1 1 1 . _ M _ _ _ _ . 7 5 C _ _	30.5	90S
72	12.85	84	3.40	7440	1 2 .		
63	14.59	95	3.14	7440	1 4 .		
57	16.09	95	3.65	7440	1 6 .		
50	18.53	119	2.71	7437	1 8 .		
44	21.05	134	2.50	7435	2 0 .		
41	22.56	130	2.85	7437	2 2 .		
37	24.86	142	2.66	7435	2 5 .		
33	28.24	161	2.41	7433	2 8 .		
28	32.55	206	1.88	7429	3 2 .		
26	35.86	201	2.03	7429	3 6 .		
23	40.74	226	1.85	7427	4 0 .		
20	46.84	291	1.39	7423	4 5 .		
18	50.93	316	1.28	7419	5 0 .		
17	55.45	302	1.48	7423	5 6 .		
15	63.00	340	1.35	7419	6 3 .		
13	73.37	447	0.89	7401	7 1 .		
10	90.67	476	1.01	7395	9 0 .		
9.3	98.57	515	0.94	7388	1 0 0		
33	28.18	170	3.82	11937	S 0 6 2 1 2 8 . _ M _ _ _ _ . 7 5 C _ _	42.5	90S
27	33.48	223	3.17	11816	3 2 .		
26	35.79	213	3.22	11826	3 6 .		
23	40.57	239	2.94	11813	4 0 .		
19	47.32	312	2.45	11803	4 5 .		
18	50.52	331	2.31	11787	5 0 .		
17	55.71	322	2.34	11787	5 6 .		
14	64.80	370	2.07	11757	6 3 .		
12	73.92	479	1.60	11626	7 1 .		
11	80.94	519	1.33	11580	8 0 .		
10	91.58	512	1.49	11680	9 0 .		
9.4	97.78	544	1.41	11580	1 0 0		
8.3	110.57	703	1.02	11450	1 1 2		
6.4	143.08	773	0.99	11500	1 4 0		
5.9	156.67	841	0.91	11400	1 6 0		
8.9	103.86	658	1.16	11539	S 0 6 3 1 1 0 0 _ M _ _ _ _ . 7 5 C _ _	47.5	90S
7.8	117.99	743	1.03	11439	1 1 8		
7.1	130.00	700	1.09	11539	1 3 2		
6.2	147.69	788	0.97	11439	1 5 0		
21	44.13	300	3.14	29168	S 0 7 2 1 4 5 . _ M _ _ _ _ . 7 5 C _ _	84.5	90S
18	49.90	339	2.82	29158	5 0 .		
17	53.62	346	2.91	29156	5 6 .		
15	61.62	398	2.61	29156	6 3 .		
13	69.00	461	2.27	29142	7 1 .		
12	75.56	505	2.10	29127	8 0 .		
10	88.26	560	1.98	29132	9 0 .		
9.2	99.79	632	1.80	29132	1 0 0		
8.8	104.32	688	1.60	29132	1 1 2		
7.9	115.92	761	1.44	29099	1 2 5		
6.7	138.00	861	1.39	29095	1 4 0		
6.1	151.12	936	1.30	29095	1 6 0		
4.4	208.65	1270	1.00	29000	2 1 2		
4.0	231.83	1405	0.90	28900	2 5 0		

NOTE

Other output speeds are available using 2 and 8 pole motors. Please contact our Application Engineers

S SERIES SELECTION TABLE GEARED MOTORS

0.75 kW
6 POLE

N2 RPM	i	M2 Nm	Fm	N	Unit Designation	kg	
Output Speed	Ratio	Output Torque	Service Factor	Overhung Load	Column Entry 1 - 20 Spaces to be filled when entering order	Weight of Base Mount unit	Motor Size
9.5	97.33	643	2.08	29078	S 0 7 3 1 1 0 0 _ M _ _ _ . 7 5 C _ _	93.5	90S
8.1	113.20	743	1.8	29048	1 1 8		
7.4	125.04	769	1.53	29096	1 3 2		
6.5	141.75	876	1.38	29065	1 5 0		
5.8	159.98	1038	1.29	28971	1 6 0		
5.4	170.81	1107	1.21	28971	1 8 0		
4.7	194.65	1187	1.07	28926	2 0 0		
4.1	226.39	1365	0.93	29000	2 2 5		
3.7	249.94	1601	0.84	28900	2 6 5		
9.3	98.53	631	3.71	41871	S 0 8 2 1 1 0 0 _ M _ _ _ . 7 5 C _ _	134.5	90S
7.8	117.89	782	3.72	41879	1 2 5		
6.6	139.29	878	2.82	41858	1 4 0		
6.0	153.00	962	2.62	41858	1 6 0		
4.5	204.75	1270	2.07	41832	S 0 8 2 1 2 1 2 _ M _ _ _ . 7 5 C _ _	134.5	90S
3.9	235.77	1443	1.81	41832	2 5 0		
3.7	249.73	1526	3.65	53800	S 0 9 2 1 2 5 0 _ M _ _ _ . 7 5 C _ _	197.5	90S
1.6	558.41	3619	1.32	53383	S 0 9 4 1 5 6 0 _ M _ _ _ . 7 5 C _ _	218.5	90S
1.4	649.47	4203	1.14	53383	6 3 0		
1.3	726.65	4692	1.02	53383	7 1 0		
1.2	774.48	5003	0.96	53383	8 0 0		
1.0	917.87	5914	0.81	53383	9 0 0		
1.9	495.31	3240	2.62	87299	S 1 0 4 1 5 0 0 _ M _ _ _ . 7 5 C _ _	336.5	90S
1.7	544.84	3561	2.38	87299	5 6 0		
1.5	626.07	4087	2.07	87299	6 3 0		
1.3	709.95	4625	1.83	87299	7 1 0		
1.2	783.06	5101	1.66	87299	8 0 0		
1.0	896.77	5832	1.45	87299	9 0 0		
0.91	1013.93	6582	1.29	87299	1 0 C		
0.82	1126.71	7285	1.14	87375	1 1 C		
0.78	1175.54	7612	1.11	87299	1 2 C		
0.66	1402.11	9048	0.94	87299	1 4 C		
0.57	1606.71	10274	0.83	87299	1 6 C		

1.1 kW
4 POLE

164	8.59	53	1.52	2831	S 0 3 2 1 8 . 0 _ M _ _ _ . 1 . 1 A _ _	24.5	90S
121	11.61	71	1.23	2824	1 1 .		
107	13.20	80	1.12	2817	1 2 .		
94	14.95	91	1.03	2817	1 4 .		
86	16.36	88	0.98	2810	1 6 .		
74	19.12	115	0.86	2800	1 8 .		
68	20.61	123	0.82	2800	2 0 .		
64	22.11	117	0.80	2800	2 2 .		
164	8.59	54	2.51	5286	S 0 4 2 1 8 . 0 _ M _ _ _ . 1 . 1 A _ _	26.5	90S
121	11.61	72	2.04	5279	1 1 .		
107	13.20	82	1.87	5280	1 2 .		
94	14.95	92	1.71	5275	1 4 .		
86	16.36	91	1.57	5275	1 6 .		
74	19.12	117	1.43	5275	1 8 .		
68	20.61	125	1.36	5275	2 0 .		
64	22.11	121	1.28	5275	2 2 .		
56	25.14	136	1.18	5268	2 5 .		
50	28.48	153	1.09	5268	2 8 .		
42	33.71	201	0.95	5254	3 2 .		
39	36.43	193	0.91	5260	3 6 .		
36	39.26	206	0.87	5260	4 0 .		
170	8.31	53	3.88	7440	S 0 5 2 1 8 . 0 _ M _ _ _ . 1 . 1 A _ _	30.5	90S
121	11.66	74	3.20	7440	1 1 .		
110	12.85	81	3.02	7440	1 2 .		
97	14.59	92	2.80	7438	1 4 .		
88	16.09	93	3.41	7440	1 6 .		
76	18.53	116	2.42	7440	1 8 .		
67	21.05	131	2.25	7437	2 0 .		
62	22.56	128	2.68	7437	2 2 .		
57	24.86	140	2.50	7437	2 5 .		
50	28.24	158	2.29	7435	2 8 .		
43	32.55	199	1.71	7433	3 2 .		
39	35.86	197	1.91	7433	3 6 .		
35	40.74	222	1.74	7433	4 0 .		
30	46.84	284	1.34	7434	4 5 .		
28	50.93	307	1.27	7428	5 0 .		
25	55.45	297	1.40	7428	5 6 .		
22	63.00	333	1.28	7422	6 3 .		
19	73.37	434	0.88	7420	7 1 .		
16	90.67	470	1.02	7410	9 0 .		
14	98.57	504	0.95	7400	1 0 0		

NOTE

Other output speeds are available using 2 and 8 pole motors. Please contact our Application Engineers

S SERIES SELECTION TABLE GEARED MOTORS

1.1 kW
4 POLE

N2 RPM	i	M2 Nm	Fm	N	Unit Designation	kg	
Output Speed	Ratio	Output Torque	Service Factor	Overhung Load	Column Entry 1 - 20 Spaces to be filled when entering order	Weight of Base Mount unit	Motor Size
67	20.96	137	3.86	11944	S 0 6 2 1 2 0 . _ M _ _ _ _ 1 . 1 A _ _	42.5	90S
56	25.11	149	3.97	11944	2 5 .		
50	28.18	167	3.65	11936	2 8 .		
42	33.48	216	2.88	11820	3 2 .		
39	35.79	208	3.05	11836	3 6 .		
35	40.57	235	2.77	11832	4 0 .		
30	47.32	302	2.30	11795	4 5 .		
28	50.52	322	2.20	11764	5 0 .		
25	55.71	317	2.20	11811	5 6 .		
22	64.80	364	1.98	11764	6 3 .		
19	73.92	463	1.64	11644	7 1 .		
17	80.94	506	1.20	11644	8 0 .		
15	91.58	503	1.52	11644	S 0 6 2 1 9 0 . _ M _ _ _ _ 1 . 1 A _ _	42.5	90S
14	97.78	534	1.43	11644	1 0 0		
13	110.57	680	0.93	11500	1 1 2		
14	103.86	637	1.20	11500	S 0 6 3 1 1 0 0 _ M _ _ _ _ 1 . 1 A _ _	47.5	90S
12	117.99	722	1.06	11400	1 1 8		
11	130.00	687	1.11	11500	1 3 2		
10	147.69	773	0.99	11500	1 5 0		
46	30.81	205	3.86	29049	S 0 7 2 1 3 2 . _ M _ _ _ _ 1 . 1 A _ _	84.5	90S
32	44.13	290	3.00	29166	4 5 .		
28	49.90	327	2.69	29166	5 0 .		
26	53.62	338	2.79	29168	5 6 .		
23	61.62	386	2.51	29152	6 3 .		
20	69.00	448	2.07	29152	7 1 .		
19	75.56	490	1.91	29136	8 0 .		
16	88.26	547	1.88	29133	9 0 .		
14	99.79	612	1.71	29133	1 0 0		
14	104.32	665	1.46	29133	1 1 2		
12	115.92	739	1.31	29100	1 2 5		
10	138.00	833	1.34	29084	1 4 0		
9.3	151.12	914	1.25	29084	1 6 0		
6.8	208.65	1234	0.97	29000	2 1 2		
6.1	231.83	1366	0.89	28900	2 5 0		
14	97.33	621	2.16	29097	S 0 7 3 1 1 0 0 _ M _ _ _ _ 1 . 1 A _ _	93.5	90S
12	113.20	718	1.87	29029	1 1 8		
11	125.04	749	1.47	29087	1 3 2		
10	141.75	839	1.33	29100	1 5 0		
16	87.29	546	3.88	41877	S 0 8 2 1 9 0 . _ M _ _ _ _ 1 . 1 A _ _	134.5	90S
14	98.53	612	3.53	41884	1 0 0		
12	117.89	756	3.77	41868	1 2 5		
10	139.29	851	2.71	41852	1 4 0		
9.2	153.00	932	2.52	41855	1 6 0		
6.9	204.75	1230	2.01	41810	2 1 2		
6.0	235.77	1409	1.79	41833	2 5 0		
9.0	156.45	952	2.85	41656	S 0 8 4 1 1 6 0 _ M _ _ _ _ 1 . 1 A _ _	150.5	90S
8.0	176.60	1069	2.66	41656	1 8 0		
6.4	219.96	1338	2.03	41656	2 1 2		
5.7	248.29	1503	1.89	41656	2 5 0		
5.1	276.74	1683	1.61	41656	2 8 0		
4.5	312.37	1891	1.50	41656	3 1 5		
4.0	351.44	2137	1.27	41656	3 6 0		
3.5	398.40	2421	1.12	41656	4 0 0		
3.1	449.70	2720	1.05	41656	4 5 0		
3.0	475.14	2886	0.94	41656	5 0 0		
2.6	547.09	3321	0.82	41656	5 6 0		
5.6	249.73	1485	3.76	53800	S 0 9 2 1 2 5 0 _ M _ _ _ _ 1 . 1 A _ _	197.5	90S
6.3	224.51	1396	3.42	53383	S 0 9 4 1 2 1 2 _ M _ _ _ _ 1 . 1 A _ _	218.5	90S
5.7	249.43	1544	3.12	53383	2 5 0		
5.0	282.46	1756	2.72	53383	2 8 0		
4.5	313.81	1942	2.48	53383	3 1 5		
3.9	358.71	2229	2.14	53383	3 6 0		
3.5	406.64	2526	1.89	53383	4 0 0		
3.1	451.77	2794	1.72	53383	4 5 0		
2.9	484.97	3010	1.59	53383	5 0 0		
2.5	558.41	3464	1.38	53383	5 6 0		
2.2	649.47	4025	1.19	53383	6 3 0		
1.9	726.65	4495	1.06	53383	7 1 0		
1.8	774.48	4794	1.00	53383	8 0 0		
1.5	917.87	5672	0.84	53383	9 0 0		

NOTE

Other output speeds are available using 2 and 8 pole motors. Please contact our Application Engineers

S SERIES SELECTION TABLE GEARED MOTORS

1.1 kW
4 POLE

1.1 kW
6 POLE

N2 RPM	i	M2 Nm	Fm	N	Unit Designation	kg			
Output Speed	Ratio	Output Torque	Service Factor	Overhung Load	Column Entry 1 - 20 Spaces to be filled when entering order	Weight of Base Mount unit	Motor Size		
2.8	495.31	3098	2.74	87299	S 1 0 4 1 5 0 0 _ M _ _ _ _ 1 . 1 A _ _	336.5	90S		
2.6	544.84	3407	2.49	87299	5 6 0				
2.3	626.07	3912	2.17	87299	6 3 0				
2.0	709.95	4428	1.91	87299	7 1 0				
1.8	783.06	4885	1.73	87299	8 0 0				
1.6	896.77	5589	1.52	87299	9 0 0				
1.4	1013.93	6311	1.34	87299	1 0 C				
1.3	1126.71	6983	1.19	87375	1 1 C				
1.2	1175.54	7304	1.16	87299	1 2 C				
1.0	1402.11	8690	0.98	87299	1 4 C				
0.88	1606.71	9836	0.87	87299	1 6 C				
108	8.59	80	1.10	2817	S 0 3 2 1 8 . 0 _ M _ _ _ _ 1 . 1 C _ _			25.5	90L
80	11.61	106	0.90	2803	1 1 .				
70	13.20	121	0.82	2796	1 2 .				
108	8.59	81	1.83	5280	S 0 4 2 1 8 . 0 _ M _ _ _ _ 1 . 1 C _ _	27.5	90L		
80	11.61	109	1.49	5271	1 1 .				
70	13.20	123	1.36	5266	1 2 .				
62	14.95	139	1.24	5266	1 4 .				
57	16.36	135	1.17	5266	1 6 .				
48	19.12	177	1.03	5261	1 8 .				
45	20.61	188	0.99	5254	2 0 .				
42	22.11	179	0.95	5254	2 2 .				
37	25.14	202	0.86	5254	2 5 .				
111	8.31	80	3.03	7440	S 0 5 2 1 8 . 0 _ M _ _ _ _ 1 . 1 C _ _			31.5	90L
79	11.66	112	2.47	7440	1 1 .				
72	12.85	123	2.33	7440	1 2 .				
63	14.59	139	2.15	7440	1 4 .				
58	16.09	138	2.51	7440	1 6 .				
50	18.53	175	1.86	7436	1 8 .				
44	21.05	196	1.72	7432	2 0 .				
41	22.56	190	1.95	7436	2 2 .				
37	24.86	208	1.82	7432	2 5 .				
33	28.24	234	1.66	7428	2 8 .				
28	32.55	300	1.29	7420	3 2 .				
26	35.86	293	1.39	7420	3 6 .				
23	40.74	330	1.27	7416	4 0 .				
20	46.84	425	0.95	7407	4 5 .				
18	50.93	462	0.88	7401	5 0 .				
17	55.45	441	1.02	7407	5 6 .				
15	63.00	496	0.93	7401	6 3 .				
71	12.97	130	3.99	11928	S 0 6 2 1 1 2 . _ M _ _ _ _ 1 . 1 C _ _	43.5	90L		
64	14.56	145	3.71	11914	1 4 .				
50	18.49	183	3.20	11900	1 8 .				
44	20.96	207	2.95	11886	2 0 .				
41	22.40	200	3.11	11900	2 2 .				
37	25.11	223	2.85	11886	2 5 .				
33	28.18	248	2.62	11879	2 8 .				
28	33.48	326	2.17	11739	3 2 .				
26	35.79	310	2.21	11759	3 6 .				
23	40.57	349	2.01	11733	4 0 .				
20	47.32	455	1.68	11693	4 5 .				
18	50.52	483	1.59	11670	5 0 .				
17	55.71	470	1.60	11670	5 6 .				
14	64.80	539	1.42	11623	6 3 .				
13	73.92	699	1.09	11473	7 1 .				
11	80.94	757	0.91	11402	8 0 .				
10	91.58	747	1.02	11502	9 0 .				
9.5	97.78	794	0.96	11402	1 0 0				
30	30.81	309	2.78	29157	S 0 7 2 1 3 2 . _ M _ _ _ _ 1 . 1 C _ _	85.5	90L		
21	44.13	439	2.15	29139	4 5 .				
19	49.90	494	1.94	29119	5 0 .				
17	53.62	505	2.00	29116	5 6 .				
15	61.62	582	1.79	29116	6 3 .				
13	69.00	673	1.56	29088	7 1 .				
12	75.56	737	1.44	29061	8 0 .				
10	88.26	817	1.36	29070	9 0 .				
9.3	99.79	923	1.24	29070	1 0 0				
8.9	104.32	1004	1.09	29070	1 1 2				
8.0	115.92	1111	0.99	29006	1 2 5				
6.7	138.00	1256	0.95	29000	1 4 0				
6.1	151.12	1365	0.89	29000	1 6 0				
10	97.33	938	1.43	29011	S 0 7 3 1 1 0 0 _ M _ _ _ _ 1 . 1 C _ _	94.5	90L		
8.2	113.20	1084	1.24	28964	1 1 8				
7.4	125.04	1122	1.05	29000	1 3 2				
6.5	141.75	1279	0.95	28941	1 5 0				

NOTE

Other output speeds are available using 2 and 8 pole motors. Please contact our Application Engineers

S SERIES SELECTION TABLE GEARED MOTORS

1.1 kW
6 POLE

N2 RPM	i	M2 Nm	Fm	N	Unit Designation	kg	
Output Speed	Ratio	Output Torque	Service Factor	Overhung Load	Column Entry 1 - 20 Spaces to be filled when entering order	Weight of Base Mount unit	Motor Size
12	76.50	754	3.77	41843	S 0 8 2 1 8 0 . _ M _ - _ - 1 . 1 C - -	135.5	90L
11	87.29	819	2.79	41859	9 0 .		
9.4	98.53	921	2.54	41844	1 0 0		
9.0	102.38	1000	3.04	41844	1 1 2		
7.8	117.89	1141	2.55	41860	1 2 5		
6.6	139.29	1281	1.94	41820	1 4 0		
6.0	153.00	1403	1.80	41820	1 6 0		
5.9	156.45	1458	1.86	41656	S 0 8 4 1 1 6 0 _ M _ - _ - 1 . 1 C - -	151.5	90L
5.2	176.60	1637	1.74	41656	1 8 0		
4.2	219.96	2048	1.33	41656	2 1 2		
3.7	248.29	2301	1.24	41656	2 5 0		
3.3	276.74	2574	1.05	41656	2 8 0		
3.0	312.37	2892	0.98	41656	3 1 5		
2.6	351.44	3265	0.83	41656	3 6 0		
7.7	119.38	1171	3.97	53755	S 0 9 2 1 1 2 5 _ M _ - _ - 1 . 1 C - -	198.5	90L
5.7	161.44	1474	3.78	53741	S 0 9 2 1 1 6 0 _ M _ - _ - 1 . 1 C - -	198.5	90L
4.2	222.08	1990	2.80	53713	2 1 2		
3.7	249.73	2227	2.51	53703	2 5 0		
5.8	159.68	1518	3.15	53383	S 0 9 4 1 1 6 0 _ M _ - _ - 1 . 1 C - -	219.5	90L
5.2	177.41	1679	2.87	53383	1 8 0		
4.1	224.51	2132	2.24	53383	2 1 2		
3.7	249.43	2360	2.04	53383	2 5 0		
3.3	282.46	2681	1.78	53383	2 8 0		
2.9	313.81	2967	1.62	53383	3 1 5		
2.6	358.71	3401	1.41	53383	3 6 0		
2.3	406.64	3853	1.24	53383	4 0 0		
2.0	451.77	4264	1.13	53383	4 5 0		
1.9	484.97	4590	1.04	53383	5 0 0		
1.7	558.41	5279	0.91	53383	5 6 0		
1.9	495.31	4726	1.79	87299	S 1 0 4 1 5 0 0 _ M _ - _ - 1 . 1 C - -	337.5	90L
1.7	544.84	5195	1.63	87299	5 6 0		
1.5	626.07	5963	1.42	87299	6 3 0		
1.3	709.95	6747	1.26	87299	7 1 0		
1.2	783.06	7441	1.14	87299	8 0 0		
1.0	896.77	8508	1.00	87299	9 0 0		
0.91	1013.93	9602	0.88	87299	1 0 C		

1.5 kW
4 POLE

165	8.59	72	1.12	2820	S 0 3 2 1 8 . 0 _ M _ - _ - 1 . 5 A - -	25.5	90L
122	11.61	96	0.91	2810	1 1 .		
108	13.20	109	0.83	2800	1 2 .		
165	8.59	73	1.85	5285	S 0 4 2 1 8 . 0 _ M _ - _ - 1 . 5 A - -	27.5	90L
122	11.61	98	1.51	5275	1 1 .		
108	13.20	111	1.38	5276	1 2 .		
95	14.95	125	1.27	5270	1 4 .		
87	16.36	123	1.16	5270	1 6 .		
74	19.12	158	1.06	5270	1 8 .		
69	20.61	170	1.01	5270	2 0 .		
64	22.11	164	0.95	5270	2 2 .		
56	25.14	185	0.87	5260	2 5 .		
50	28.48	207	0.80	5260	2 8 .		
171	8.31	72	2.87	7440	S 0 5 2 1 8 . 0 _ M _ - _ - 1 . 5 A - -	31.5	90L
122	11.66	100	2.36	7440	1 1 .		
111	12.85	110	2.23	7440	1 2 .		
97	14.59	125	2.07	7437	1 4 .		
88	16.09	126	2.52	7440	1 6 .		
77	18.53	157	1.79	7440	1 8 .		
67	21.05	177	1.66	7436	2 0 .		
63	22.56	174	1.98	7436	2 2 .		
57	24.86	190	1.85	7436	2 5 .		
50	28.24	214	1.69	7432	2 8 .		
44	32.55	270	1.26	7428	3 2 .		
40	35.86	268	1.41	7428	3 6 .		
35	40.74	301	1.29	7428	4 0 .		
30	46.84	384	0.99	7430	4 5 .		
28	50.93	415	0.94	7420	5 0 .		
26	55.45	402	1.03	7420	5 6 .		
23	63.00	451	0.95	7410	6 3 .		

NOTE

Other output speeds are available using 2 and 8 pole motors. Please contact our Application Engineers

S SERIES SELECTION TABLE GEARED MOTORS

1.5 kW
4 POLE

N2 RPM	i	M2 Nm	Fm	N	Unit Designation	kg	
Output Speed	Ratio	Output Torque	Service Factor	Overhung Load	Column Entry 1 - 20 Spaces to be filled when entering order	Weight of Base Mount unit	Motor Size
109	12.97	116	3.82	11945	S 0 6 2 1 1 2 . _ M _ - _ - 1 . 5 A - -	43.5	90L
98	14.56	130	3.56	11923	1 4 .		
89	15.93	131	3.94	11942	1 6 .		
77	18.49	164	3.08	11904	1 8 .		
68	20.96	186	2.85	11904	2 0 .		
63	22.40	182	3.18	11904	2 2 .		
57	25.11	202	2.93	11904	2 5 .		
50	28.18	226	2.70	11889	2 8 .		
42	33.48	292	2.13	11762	3 2 .		
40	35.79	282	2.25	11789	3 6 .		
35	40.57	318	2.04	11783	4 0 .		
30	47.32	409	1.70	11712	4 5 .		
28	50.52	436	1.63	11668	5 0 .		
25	55.71	429	1.63	11734	5 6 .		
22	64.80	493	1.46	11668	6 3 .		
19	73.92	627	1.21	11500	7 1 .		
18	80.94	685	0.89	11500	8 0 .		
16	91.58	682	1.12	11500	9 0 .		
15	97.78	724	1.06	11500	1 0 0		
46	30.81	278	2.85	28940	S 0 7 2 1 3 2 . _ M _ - _ - 1 . 5 A - -	85.5	90L
32	44.13	393	2.21	29142	4 5 .		
28	49.90	443	1.98	29142	5 0 .		
26	53.62	458	2.06	29144	5 6 .		
23	61.62	523	1.85	29117	S 0 7 2 1 6 3 . _ M _ - _ - 1 . 5 A - -	85.5	90L
21	69.00	606	1.53	29117	7 1 .		
19	75.56	663	1.41	29089	8 0 .		
16	88.26	740	1.39	29084	9 0 .		
14	99.79	829	1.27	29084	1 0 0		
14	104.32	901	1.08	29084	1 1 2		
12	115.92	1000	0.97	29027	1 2 5		
10	138.00	1128	0.99	29000	1 4 0		
9.4	151.12	1238	0.92	29000	1 6 0		
15	97.33	841	1.59	29056	S 0 7 3 1 1 0 0 _ M _ - _ - 1 . 5 A - -	94.5	90L
13	113.20	972	1.38	28960	1 1 8		
11	125.04	1014	1.08	29006	1 3 2		
10	141.75	1136	0.99	29027	1 5 0		
8.9	159.98	1359	0.99	28868	1 6 0		
8.3	170.81	1445	0.93	28900	1 8 0		
19	76.50	677	3.78	41845	S 0 8 2 1 8 0 . _ M _ - _ - 1 . 5 A - -	135.5	90L
16	87.29	739	2.87	41861	9 0 .		
14	98.53	829	2.60	41872	1 0 0		
14	102.38	897	3.08	41872	1 1 2		
12	117.89	1024	2.78	41844	1 2 5		
10	139.29	1152	2.00	41817	1 4 0		
9.3	153.00	1262	1.86	41822	1 6 0		
6.9	204.75	1666	1.48	41744	2 1 2		
6.0	235.77	1908	1.33	41784	2 5 0		
9.1	156.45	1290	2.11	41656	S 0 8 4 1 1 6 0 _ M _ - _ - 1 . 5 A - -	151.5	90L
8.0	176.60	1448	1.96	41656	1 8 0		
6.5	219.96	1812	1.50	41656	2 1 2		
5.7	248.29	2035	1.40	41656	2 5 0		
5.1	276.74	2279	1.19	41656	2 8 0		
4.5	312.37	2560	1.11	41656	3 1 5		
4.0	351.44	2893	0.94	41656	3 6 0		
3.6	398.40	3279	0.83	41656	4 0 0		
6.4	222.08	1803	3.09	53736	S 0 9 2 1 2 1 2 _ M _ - _ - 1 . 5 A - -	198.5	90L
5.7	249.73	2011	2.77	53727	2 5 0		
8.9	159.68	1345	3.55	53383	S 0 9 4 1 1 6 0 _ M _ - _ - 1 . 5 A - -	219.5	90L
8.0	177.41	1488	3.24	53383	1 8 0		
6.3	224.51	1891	2.53	53383	2 1 2		
5.7	249.43	2091	2.30	53383	2 5 0		
5.0	282.46	2378	2.01	53383	2 8 0		
4.5	313.81	2630	1.83	53383	3 1 5		
4.0	358.71	3018	1.58	53383	3 6 0		
3.5	406.64	3420	1.40	53383	4 0 0		
3.1	451.77	3783	1.27	53383	4 5 0		
2.9	484.97	4076	1.17	53383	5 0 0		
2.5	558.41	4690	1.02	53383	5 6 0		
2.2	649.47	5450	0.88	53383	6 3 0		
2.9	495.31	4195	2.02	87299	S 1 0 4 1 5 0 0 _ M _ - _ - 1 . 5 A - -	337.5	90L
2.6	544.84	4613	1.84	87299	5 6 0		
2.3	626.07	5297	1.60	87299	6 3 0		
2.0	709.95	5996	1.41	87299	7 1 0		
1.8	783.06	6615	1.28	87299	8 0 0		
1.6	896.77	7568	1.12	87299	9 0 0		
1.4	1013.93	8545	0.99	87299	1 0 C		
1.3	1126.71	9455	0.88	87375	1 1 C		
1.2	1175.54	9890	0.86	87299	1 2 C		

NOTE

Other output speeds are available using 2 and 8 pole motors. Please contact our Application Engineers

S SERIES SELECTION TABLE GEARED MOTORS

1.5 kW
6 POLE

N2 RPM	i	M2 Nm	Fm	N	Unit Designation	kg	
Output Speed	Ratio	Output Torque	Service Factor	Overhung Load	Column Entry 1 - 20 Spaces to be filled when entering order	Weight of Base Mount unit	Motor Size
108	8.59	109	0.81	2800	S 0 3 2 1 8 . 0 _ M _ _ _ _ 1 . 5 C - -	35	100L
108	8.59	111	1.34	5276	S 0 4 2 1 8 . 0 _ M _ _ _ _ 1 . 5 C - -	37	100L
80	11.61	149	1.09	5263	1 1 .		
70	13.20	167	1.00	5256	1 2 .		
62	14.95	189	0.91	5256	1 4 .		
57	16.36	184	0.85	5256	1 6 .		
111	8.31	110	2.22	7440	S 0 5 2 1 8 . 0 _ M _ _ _ _ 1 . 5 C - -	41	100L
79	11.66	152	1.81	7440	1 1 .		
72	12.85	167	1.71	7440	1 2 .		
63	14.59	189	1.58	7440	1 4 .		
58	16.09	189	1.84	7440	1 6 .		
50	18.53	238	1.36	7433	1 8 .		
44	21.05	268	1.26	7427	2 0 .		
41	22.56	259	1.43	7433	2 2 .		
37	24.86	284	1.34	7427	2 5 .		
33	28.24	320	1.21	7421	2 8 .		
28	32.55	409	0.94	7409	3 2 .		
26	35.86	400	1.02	7409	3 6 .		
23	40.74	450	0.93	7402	4 0 .		
112	8.23	114	3.85	11933	S 0 6 2 1 8 . 0 _ M _ _ _ _ 1 . 5 C - -	53	100L
80	11.57	158	3.13	11911	1 1 .		
71	12.97	177	2.92	11889	1 2 .		
64	14.56	198	2.72	11867	1 4 .		
58	15.93	198	2.94	11889	1 6 .		
50	18.49	250	2.34	11845	1 8 .		
44	20.96	282	2.16	11823	2 0 .		
41	22.40	273	2.28	11845	2 2 .		
37	25.11	304	2.09	11823	2 5 .		
33	28.18	339	1.92	11813	2 8 .		
28	33.48	445	1.59	11650	3 2 .		
26	35.79	423	1.62	11682	3 6 .		
23	40.57	477	1.48	11642	4 0 .		
20	47.32	621	1.23	11568	4 5 .		
18	50.52	658	1.16	11535	5 0 .		
17	55.71	642	1.18	11535	5 6 .		
14	64.80	736	1.04	11469	6 3 .		
13	73.92	953	0.80	11300	7 1 .		
59	15.80	214	3.73	29200	S 0 7 2 1 1 6 . _ M _ _ _ _ 1 . 5 C - -	95	100L
46	20.07	278	3.80	29200	2 0 .		
42	21.89	293	2.93	29200	2 2 .		
38	24.59	328	2.69	29200	2 5 .		
34	27.03	359	2.50	29200	2 8 .		
30	30.81	422	2.04	29133	3 2 .		
26	35.31	464	2.04	29200	3 6 .		
23	40.15	524	1.84	29200	4 0 .		
21	44.13	598	1.58	29106	4 5 .		
19	49.90	674	1.42	29075	5 0 .		
17	53.62	689	1.46	29071	5 6 .		
15	61.62	793	1.31	29071	6 3 .		
13	69.00	918	1.14	29028	7 1 .		
12	75.56	1006	1.05	28985	8 0 .		
10	88.26	1114	1.00	29000	9 0 .		
9.3	99.79	1258	0.91	29000	1 0 0 .		
8.9	104.32	1369	0.80	29000	1 1 2 .		
10	97.33	1279	1.05	28934	S 0 7 3 1 1 0 0 _ M _ _ _ _ 1 . 5 C - -	104	100L
8.2	113.20	1479	0.91	28868	1 1 8 .		
23	39.51	524	3.80	41900	S 0 8 2 1 4 0 . _ M _ _ _ _ 1 . 5 C - -	145	100L
19	49.26	672	3.78	41836	5 0 .		
17	54.60	713	2.94	41900	5 6 .		
15	63.56	824	2.61	41900	6 3 .		
13	69.64	938	2.96	41811	7 1 .		
12	76.50	1028	2.76	41811	8 0 .		
11	87.29	1117	2.05	41837	9 0 .		
9.4	98.53	1256	1.86	41814	1 0 0 .		
9.0	102.38	1363	2.23	41814	1 1 2 .		
7.8	117.89	1556	1.87	41838	1 2 5 .		
6.6	139.29	1746	1.42	41776	1 4 0 .		
6.0	153.00	1913	1.32	41776	1 6 0 .		
4.5	204.75	2527	1.04	41700	2 1 2 .		
3.9	235.77	2872	0.91	41700	2 5 0 .		
5.9	156.45	1988	1.37	41656	S 0 8 4 1 1 6 0 _ M _ _ _ _ 1 . 5 C - -	161	100L
5.2	176.60	2233	1.27	41656	1 8 0 .		
4.2	219.96	2792	0.97	41656	2 1 2 .		
3.7	248.29	3137	0.91	41656	2 5 0 .		
8.7	106.17	1432	3.22	53721	S 0 9 2 1 1 1 2 _ M _ _ _ _ 1 . 5 C - -	208	100L
7.7	119.38	1597	2.91	53705	1 2 5 .		
6.3	146.23	1828	3.05	53689	1 4 0 .		
5.7	161.44	2010	2.78	53673	1 6 0 .		
4.2	222.08	2714	2.06	53615	2 1 2 .		
3.7	249.73	3037	1.84	53592	2 5 0 .		

NOTE

Other output speeds are available using 2 and 8 pole motors. Please contact our Application Engineers

S SERIES SELECTION TABLE GEARED MOTORS

1.5 kW
6 POLE

2.2 kW
4 POLE

N2 RPM	i	M2 Nm	Fm	N	Unit Designation	kg	
Output Speed	Ratio	Output Torque	Service Factor	Overhung Load	Column Entry 1 - 20 Spaces to be filled when entering order	Weight of Base Mount unit	Motor Size
5.8	159.68	2070	2.31	53383	S 0 9 4 1 1 6 0 _ M _ _ _ 1 . 5 C _ _	229	100L
5.2	177.41	2290	2.10	53383	1 8 0		
4.1	224.51	2908	1.64	53383	2 1 2		
3.7	249.43	3218	1.50	53383	2 5 0		
3.3	282.46	3656	1.31	53383	2 8 0		
2.9	313.81	4046	1.19	53383	3 1 5		
2.6	358.71	4638	1.03	53383	3 6 0		
2.3	406.64	5255	0.91	53383	4 0 0		
2.0	451.77	5815	0.83	53383	4 5 0		
5.5	166.73	2139	3.98	87400	S 1 0 2 1 1 6 0 _ M _ _ _ 1 . 5 C _ _	305	100L
4.1	225.50	2845	3.10	87400	2 1 2		
3.8	242.27	3044	2.90	87400	2 5 0		
1.9	495.31	6445	1.31	87299	S 1 0 4 1 5 0 0 0 _ M _ _ _ 1 . 5 C _ _	347	100L
1.7	544.84	7085	1.20	87299	5 6 0		
1.5	626.07	8131	1.04	87299	6 3 0		
1.3	709.95	9200	0.92	87299	7 1 0		
1.2	783.06	10147	0.84	87299	8 0 0		
166	8.59	107	1.27	5282	S 0 4 2 1 8 . 0 _ M _ _ _ 2 . 2 A _ _	37	100L
123	11.61	144	1.03	5288	1 1 .		
108	13.20	163	0.94	5270	1 2 .		
95	14.95	183	0.87	5260	1 4 .		
171	8.31	106	1.96	7440	S 0 5 2 1 8 . 0 _ M _ _ _ 2 . 2 A _ _	41	100L
122	11.66	147	1.62	7440	1 1 .		
111	12.85	161	1.53	7440	1 2 .		
98	14.59	182	1.42	7435	1 4 .		
89	16.09	185	1.72	7440	1 6 .		
77	18.53	230	1.22	7440	1 8 .		
68	21.05	259	1.13	7433	2 0 .		
63	22.56	254	1.35	7433	2 2 .		
57	24.86	278	1.26	7433	2 5 .		
50	28.24	312	1.16	7426	2 8 .		
44	32.55	395	0.86	7420	3 2 .		
40	35.86	391	0.96	7420	3 6 .		
35	40.74	440	0.88	7420	4 0 .		
173	8.23	109	3.40	11928	S 0 6 2 1 8 . 0 _ M _ _ _ 2 . 2 A _ _	53	100L
123	11.57	152	2.80	11905	1 1 .		
110	12.97	170	2.61	11905	1 2 .		
98	14.56	191	2.44	11866	1 4 .		
89	15.93	191	2.69	11900	1 6 .		
77	18.49	240	2.11	11833	1 8 .		
68	20.96	272	1.95	11833	2 0 .		
64	22.40	266	2.18	11833	2 2 .		
57	25.11	296	2.01	11833	2 5 .		
51	28.18	331	1.84	11808	2 8 .		
43	33.48	427	1.46	11660	3 2 .		
40	35.79	413	1.54	11708	3 6 .		
35	40.57	465	1.40	11697	4 0 .		
30	47.32	598	1.16	11566	4 5 .		
28	50.52	637	1.11	11500	5 0 .		
26	55.71	627	1.11	11600	5 6 .		
22	64.80	720	1.00	11500	6 3 .		
90	15.80	205	3.49	27500	S 0 7 2 1 1 6 . _ M _ _ _ 2 . 2 A _ _	95	100L
81	17.66	237	3.70	28200	1 8 .		
71	20.07	269	3.42	29200	2 0 .		
65	21.89	282	2.77	29200	2 2 .		
58	24.59	315	2.54	29200	2 5 .		
53	27.03	347	2.37	29200	2 8 .		
46	30.81	406	1.95	28748	3 2 .		
40	35.31	448	1.94	29200	3 6 .		
35	40.15	507	1.76	29200	4 0 .		
32	44.13	575	1.51	29100	4 5 .		
29	49.90	648	1.36	29100	5 0 .		
27	53.62	670	1.41	29104	5 6 .		
23	61.62	764	1.27	29056	6 3 .		
21	69.00	886	1.05	29056	7 1 .		
19	75.56	970	0.96	29008	8 0 .		
16	88.26	1082	0.95	29000	9 0 .		
14	99.79	1211	0.87	29000	1 0 0		
15	97.33	1229	1.09	28983	S 0 7 3 1 1 0 0 0 _ M _ _ _ 2 . 2 A _ _	104	100L
13	113.20	1421	0.94	28838	1 1 8		

NOTE

Other output speeds are available using 2 and 8 pole motors. Please contact our Application Engineers

S SERIES SELECTION TABLE GEARED MOTORS

2.2 kW

4 POLE

N2 RPM	i	M2 Nm	Fm	N	Unit Designation	kg	
Output Speed	Ratio	Output Torque	Service Factor	Overhung Load	Column Entry 1 - 20 Spaces to be filled when entering order	Weight of Base Mount unit	Motor Size
40	35.20	453	3.97	41900	S 0 8 2 1 3 6 . _ M _ _ _ 2 . 2 A -	145	100L
36	39.51	506	3.64	41900	4 0 .		
33	43.64	576	3.77	41063	4 5 .		
29	49.26	646	3.48	41638	5 0 .		
26	54.60	690	2.84	41900	5 6 .		
22	63.56	797	2.52	41900	6 3 .		
20	69.64	901	2.76	41828	7 1 .		
19	76.50	989	2.59	41805	8 0 .		
16	87.29	1081	1.96	41833	9 0 .		
14	98.53	1211	1.78	41852	1 0 0		
14	102.38	1311	2.10	41852	1 1 2		
12	117.89	1497	1.90	41804	1 2 5		
10	139.29	1684	1.37	41756	1 4 0		
9.3	153.00	1845	1.27	41765	1 6 0		
7.0	204.75	2435	1.01	41630	2 1 2		
6.0	235.77	2789	0.91	41700	2 5 0		
9.1	156.45	1885	1.44	41656	S 0 8 4 1 1 6 0 _ M _ _ _ 2 . 2 A -	161	100L
8.1	176.60	2117	1.34	41656	1 8 0		
6.5	219.96	2649	1.03	41656	2 1 2		
5.7	248.29	2975	0.96	41656	2 5 0		
5.1	276.74	3332	0.82	41656	2 8 0		
14	103.53	1280	3.79	53722	S 0 9 2 1 1 0 0 _ M _ _ _ 2 . 2 A -	208	100L
13	106.17	1376	3.23	53731	1 1 2		
12	119.38	1539	2.92	53714	1 2 5		
10	146.23	1772	2.98	53696	1 4 0		
8.8	161.44	1950	2.78	53679	1 6 0		
6.4	222.08	2635	2.12	53625	2 1 2		
5.7	249.73	2939	1.90	53600	2 5 0		
8.9	159.68	1966	2.43	53383	S 0 9 4 1 1 6 0 _ M _ _ _ 2 . 2 A -	229	100L
8.0	177.41	2175	2.21	53383	1 8 0		
6.3	224.51	2763	1.73	53383	2 1 2		
5.7	249.43	3057	1.58	53383	2 5 0		
5.0	282.46	3475	1.38	53383	2 8 0		
4.5	313.81	3844	1.25	53383	3 1 5		
4.0	358.71	4411	1.08	53383	3 6 0		
3.5	406.64	4998	0.96	53383	4 0 0		
3.2	451.77	5530	0.87	53383	4 5 0		
2.9	484.97	5957	0.80	53383	5 0 0		
8.5	166.73	2067	3.85	87400	S 1 0 2 1 1 6 0 _ M _ _ _ 2 . 2 A -	305	100L
6.3	225.50	2755	3.04	87400	2 1 2		
5.9	242.27	2948	2.87	87400	2 5 0		
2.9	495.31	6132	1.38	87299	S 1 0 4 1 5 0 0 _ M _ _ _ 2 . 2 A -	347	100L
2.6	544.84	6742	1.26	87299	5 6 0		
2.3	626.07	7741	1.09	87299	6 3 0		
2.0	709.95	8763	0.97	87299	7 1 0		
1.8	783.06	9669	0.88	87299	8 0 0		

2.2 kW

6 POLE

111	8.59	159	0.94	5270	S 0 4 2 1 8 . 0 _ M _ _ _ 2 . 2 C -	45	112M
114	8.31	157	1.56	7440	S 0 5 2 1 8 . 0 _ M _ _ _ 2 . 2 C -	49	112M
81	11.66	218	1.27	7440	1 1 .		
74	12.85	239	1.20	7440	1 2 .		
65	14.59	271	1.11	7440	1 4 .		
59	16.09	270	1.29	7440	1 6 .		
51	18.53	340	0.95	7430	1 8 .		
45	21.05	383	0.88	7420	2 0 .		
42	22.56	370	1.00	7430	2 2 .		
38	24.86	406	0.94	7420	2 5 .		
34	28.24	457	0.85	7410	2 8 .		
115	8.23	162	2.69	11892	S 0 6 2 1 8 . 0 _ M _ _ _ 2 . 2 C -	65	112M
82	11.57	226	2.20	11857	1 1 .		
73	12.97	253	2.05	11821	1 2 .		
65	14.56	283	1.90	11785	1 4 .		
60	15.93	283	2.06	11821	1 6 .		
51	18.49	357	1.64	11750	1 8 .		
45	20.96	403	1.52	11714	2 0 .		
42	22.40	390	1.60	11750	2 2 .		
38	25.11	435	1.46	11714	2 5 .		
34	28.18	484	1.34	11697	2 8 .		
28	33.48	635	1.12	11496	3 2 .		
27	35.79	605	1.13	11547	3 6 .		
23	40.57	681	1.03	11482	4 0 .		
20	47.32	886	0.86	11350	4 5 .		
19	50.52	940	0.81	11300	5 0 .		
17	55.71	917	0.82	11300	5 6 .		

NOTE

Other output speeds are available using 2 and 8 pole motors. Please contact our Application Engineers

S SERIES SELECTION TABLE GEARED MOTORS

2.2 kW

6 POLE

N2 RPM	i	M2 Nm	Fm	N	Unit Designation	kg	
Output Speed	Ratio	Output Torque	Service Factor	Overhung Load	Column Entry 1 - 20 Spaces to be filled when entering order	Weight of Base Mount unit	Motor Size
120	7.90	160	3.84	24856	S 0 7 2 1 8 . 0 _ M _ _ _ 2 . 2 C - -	109	112M
87	10.94	221	3.84	26975	1 1 .		
77	12.29	248	3.61	27838	1 2 .		
70	13.52	272	3.41	28591	1 4 .		
60	15.80	305	2.61	28978	1 6 .		
54	17.66	353	2.89	28908	1 8 .		
47	20.07	398	2.66	28966	2 0 .		
43	21.89	419	2.05	29165	2 2 .		
39	24.59	468	1.88	29165	2 5 .		
35	27.03	513	1.75	29165	S 0 7 2 1 2 8 . _ M _ _ _ 2 . 2 C - -	109	112M
31	30.81	603	1.43	29092	3 2 .		
27	35.31	663	1.43	29144	3 6 .		
24	40.15	749	1.29	29116	4 0 .		
22	44.13	854	1.11	29048	4 5 .		
19	49.90	963	0.99	28998	5 0 .		
18	53.62	984	1.03	28991	5 6 .		
15	61.62	1133	0.92	28991	6 3 .		
14	69.00	1311	0.80	28921	7 1 .		
39	24.47	474	3.84	41597	S 0 8 2 1 2 5 . _ M _ _ _ 2 . 2 C - -	152	112M
35	27.22	524	3.54	41795	2 8 .		
30	31.78	626	3.56	41748	3 2 .		
27	35.20	670	2.91	41888	3 6 .		
24	39.51	748	2.66	41876	4 0 .		
22	43.64	855	2.87	41848	4 5 .		
19	49.26	960	2.64	41797	5 0 .		
17	54.60	1019	2.06	41865	5 6 .		
15	63.56	1177	1.83	41847	6 3 .		
14	69.64	1340	2.07	41757	7 1 .		
12	76.50	1468	1.93	41757	8 0 .		
11	87.29	1595	1.43	41799	9 0 .		
10	98.53	1793	1.30	41760	1 0 0		
9.3	102.38	1947	1.56	41760	1 1 2		
8.1	117.89	2223	1.31	41800	1 2 5		
6.8	139.29	2494	0.99	41700	1 4 0		
6.2	153.00	2732	0.92	41700	1 6 0		
6.1	156.45	2839	0.96	41656	S 0 8 4 1 1 6 0 _ M _ _ _ 2 . 2 C - -	175	112M
5.4	176.60	3189	0.89	41656	1 8 0		
14	69.91	1363	3.26	53714	S 0 9 2 1 7 1 . _ M _ _ _ 2 . 2 C - -	215	112M
12	77.18	1502	2.98	53692	8 0 .		
10	93.18	1703	3.08	53671	9 0 .		
9.2	103.53	1883	2.86	53649	1 0 0		
8.9	106.17	2045	2.25	53647	1 1 2		
8.0	119.38	2282	2.04	53616	1 2 5		
6.5	146.23	2611	2.14	53586	1 4 0		
5.9	161.44	2871	1.94	53555	1 6 0		
4.3	222.08	3876	1.44	53443	2 1 2		
3.8	249.73	4337	1.29	53398	2 5 0		
5.9	159.68	2956	1.62	53383	S 0 9 4 1 1 6 0 _ M _ _ _ 2 . 2 C - -	243	112M
5.4	177.41	3270	1.47	53383	1 8 0		
4.2	224.51	4153	1.15	53383	2 1 2		
3.8	249.43	4596	1.05	53383	2 5 0		
3.4	282.46	5221	0.92	53383	2 8 0		
3.0	313.81	5778	0.83	53383	3 1 5		
8.2	115.82	2240	3.53	87400	S 1 0 2 1 1 2 5 _ M _ _ _ 2 . 2 C - -	312	112M
6.6	144.71	2668	3.12	87376	1 4 0		
5.7	166.73	3055	2.79	87365	1 6 0		
4.2	225.50	4064	2.17	87347	2 1 2		
3.9	242.27	4347	2.03	87347	2 5 0		
1.9	495.31	9204	0.92	87299	S 1 0 4 1 5 0 0 _ M _ _ _ 2 . 2 C - -	361	112M
1.7	544.84	10117	0.84	87299	5 6 0		

NOTE

Other output speeds are available using 2 and 8 pole motors. Please contact our Application Engineers

S SERIES SELECTION TABLE GEARED MOTORS

3.0 kW
4 POLE

N2 RPM	i	M2 Nm	Fm	N	Unit Designation	kg	
Output Speed	Ratio	Output Torque	Service Factor	Overhung Load	Column Entry 1 - 20 Spaces to be filled when entering order	Weight of Base Mount unit	Motor Size
166	8.59	147	0.93	5280	S 0 4 2 1 8 . 0 _ M _ _ _ 3 . 0 A - -	37	100L
171	8.31	145	1.44	7440	S 0 5 2 1 8 . 0 _ M _ _ _ 3 . 0 A - -	41	100L
122	11.66	200	1.19	7440	1 1 .		
111	12.85	220	1.12	7440	1 2 .		
98	14.59	249	1.04	7432	1 4 .		
89	16.09	253	1.26	7440	1 6 .		
77	18.53	314	0.90	7440	1 8 .		
68	21.05	354	0.83	7430	2 0 .		
63	22.56	347	0.99	7430	2 2 .		
57	24.86	379	0.93	7430	2 5 .		
50	28.24	426	0.85	7420	2 8 .		
173	8.23	149	2.50	11894	S 0 6 2 1 8 . 0 _ M _ _ _ 3 . 0 A - -	53	100L
123	11.57	208	2.05	11858	1 1 .		
110	12.97	232	1.92	11858	1 2 .		
98	14.56	260	1.79	11802	1 4 .		
89	15.93	261	1.98	11851	1 6 .		
77	18.49	328	1.55	11752	1 8 .		
68	20.96	370	1.43	11752	2 0 .		
64	22.40	362	1.60	11752	2 2 .		
57	25.11	403	1.47	11752	2 5 .		
51	28.18	451	1.35	11715	2 8 .		
43	33.48	583	1.07	11544	3 2 .		
40	35.79	563	1.13	11615	3 6 .		
35	40.57	634	1.03	11600	S 0 6 2 1 4 0 . _ M _ _ _ 3 . 0 A - -	53	100L
30	47.32	815	0.85	11400	4 5 .		
130	10.94	201	3.64	24654	S 0 7 2 1 1 1 . _ M _ _ _ 3 . 0 A - -	95	100L
116	12.29	227	3.37	25318	1 2 .		
105	13.52	249	3.19	25990	1 4 .		
90	15.80	279	2.56	27218	1 6 .		
81	17.66	323	2.72	27800	1 8 .		
71	20.07	367	2.51	28732	2 0 .		
65	21.89	385	2.03	28898	2 2 .		
58	24.59	430	1.86	28943	2 5 .		
53	27.03	473	1.74	29018	2 8 .		
46	30.81	554	1.43	28530	3 2 .		
40	35.31	611	1.42	29151	3 6 .		
35	40.15	691	1.29	29151	4 0 .		
32	44.13	785	1.11	29051	4 5 .		
29	49.90	883	1.00	29051	5 0 .		
27	53.62	913	1.04	29057	5 6 .		
23	61.62	1042	0.93	28986	6 3 .		
58	24.47	434	3.80	38856	S 0 8 2 1 2 5 . _ M _ _ _ 3 . 0 A - -	145	100L
52	27.22	480	3.54	39518	2 8 .		
45	31.78	577	3.37	40736	3 2 .		
40	35.20	618	2.91	41500	3 6 .		
36	39.51	690	2.67	41563	4 0 .		
33	43.64	785	2.76	40657	4 5 .		
29	49.26	881	2.55	41512	5 0 .		
26	54.60	942	2.08	41884	5 6 .		
22	63.56	1087	1.85	41869	6 3 .		
20	69.64	1229	2.02	41794	7 1 .		
19	76.50	1349	1.90	41758	8 0 .		
16	87.29	1474	1.44	41801	9 0 .		
14	98.53	1652	1.31	41828	1 0 0		
14	102.38	1788	1.54	41828	1 1 2		
12	117.89	2042	1.40	41757	1 2 5		
10	139.29	2296	1.01	41686	1 4 0		
9.3	153.00	2517	0.93	41700	1 6 0		
9.1	156.45	2570	1.06	41656	S 0 8 4 1 1 6 0 _ M _ _ _ 3 . 0 A - -	161	100L
8.1	176.60	2887	0.99	41656	1 8 0		
20	69.91	1250	3.41	53723	S 0 9 2 1 7 1 . _ M _ _ _ 3 . 0 A - -	208	100L
18	77.18	1380	3.12	53704	8 0 .		
15	93.18	1578	2.98	53684	9 0 .		
14	103.53	1745	2.78	53665	1 0 0		
13	106.17	1877	2.37	53681	1 1 2		
12	119.38	2098	2.14	53651	1 2 5		
10	146.23	2417	2.19	53621	1 4 0		
8.8	161.44	2660	2.04	53592	1 6 0		
6.4	222.08	3593	1.55	53497	2 1 2		
5.7	249.73	4007	1.39	53454	2 5 0		
8.9	159.68	2681	1.78	53383	S 0 9 4 1 1 6 0 _ M _ _ _ 3 . 0 A - -	229	100L
8.0	177.41	2966	1.62	53383	1 8 0		
6.3	224.51	3769	1.27	53383	2 1 2		
5.7	249.43	4169	1.16	53383	2 5 0		
5.0	282.46	4739	1.01	53383	2 8 0		
4.5	313.81	5243	0.92	53383	3 1 5		

NOTE

Other output speeds are available using 2 and 8 pole motors. Please contact our Application Engineers

S SERIES SELECTION TABLE GEARED MOTORS

3.0 kW

4 POLE

3.0 kW

6 POLE

NOTE

Other output speeds are available using 2 and 8 pole motors. Please contact our Application Engineers

N2 RPM	i	M2 Nm	Fm	N	Unit Designation	kg				
Output Speed	Ratio	Output Torque	Service Factor	Overhung Load	Column Entry 1 - 20 Spaces to be filled when entering order	Weight of Base Mount unit	Motor Size			
12	115.82	2064	3.87	87400	S 1 0 2 1 1 2 5 _ M _ _ _ 3 . 0 A - -	305	100L			
10	144.71	2462	3.15	87381						
8.5	166.73	2818	2.82	87372						
6.3	225.50	3757	2.23	87369						
5.9	242.27	4021	2.11	87369						
2.9	495.31	8361	1.01	87299	S 1 0 4 1 5 0 0 _ M _ _ _ 3 . 0 A - -	347	100L			
2.6	544.84	9194	0.92	87299						
2.3	626.07	10557	0.80	87299						
116	8.23	221	1.99	11846	S 0 6 2 1 8 . 0 _ M _ _ _ 3 . 0 C - -	82	132S			
83	11.57	307	1.62	11794						
74	12.97	343	1.51	11743						
66	14.56	384	1.40	11692						
60	15.93	384	1.52	11743						
52	18.49	484	1.21	11641						
46	20.96	547	1.12	11589						
43	22.40	530	1.18	11641						
38	25.11	590	1.08	11589						
34	28.18	657	0.99	11565						
29	33.48	862	0.82	11320						
27	35.79	820	0.84	11392						
121	7.90	217	2.83	24578				S 0 7 2 1 8 . 0 _ M _ _ _ 3 . 0 C - -	126	132S
87	10.94	300	2.83	26605						
78	12.29	336	2.66	27425						
71	13.52	369	2.51	28125						
60	15.80	414	1.92	28725						
54	17.66	479	2.13	28575						
48	20.07	539	1.96	28700						
44	21.89	568	1.51	29125						
39	24.59	635	1.39	29125						
35	27.03	696	1.29	29125						
31	30.81	818	1.05	29046						
27	35.31	899	1.05	29080						
24	40.15	1016	0.95	29020						
22	44.13	1159	0.82	28982						
61	15.54	414	3.91	37968	S 0 8 2 1 1 6 . _ M _ _ _ 3 . 0 C - -	169	132S			
54	17.60	479	3.81	38900						
48	19.76	538	3.55	40105						
43	22.03	581	3.06	41142						
39	24.47	643	2.83	41252						
35	27.22	711	2.61	41675						
30	31.78	850	2.62	41575						
27	35.20	908	2.15	41875						
24	39.51	1015	1.96	41850						
22	43.64	1160	2.12	41826						
19	49.26	1302	1.95	41752						
17	54.60	1382	1.52	41825						
15	63.56	1596	1.35	41787						
14	69.64	1818	1.53	41694						
12	76.50	1991	1.43	41694						
11	87.29	2164	1.06	41755						
10	98.53	2433	0.96	41700						
9.3	102.38	2642	1.15	41700						
21	44.55	1195	3.55	53734	S 0 9 2 1 4 5 . _ M _ _ _ 3 . 0 C - -	232	132S			
19	49.49	1326	3.23	53712						
14	69.91	1849	2.40	53666						
12	77.18	2037	2.20	53633						
10	93.18	2310	2.27	53600						
9.2	103.53	2555	2.11	53566						
9.0	106.17	2774	1.66	53563						
8.0	119.38	3095	1.50	53515						
6.5	146.23	3542	1.58	53468						
5.9	161.44	3895	1.43	53421						
4.3	222.08	5258	1.06	53246						
3.8	249.73	5883	0.95	53176						
6.0	159.68	4010	1.19	53383				S 0 9 4 1 1 6 0 _ M _ _ _ 3 . 0 C - -	260	132S
5.4	177.41	4437	1.09	53383						
4.3	224.51	5634	0.85	53383						
10	91.32	2328	3.30	87384	S 1 0 2 1 9 0 . _ M _ _ _ 3 . 0 C - -	329	132S			
9.4	101.47	2575	3.04	87368						
8.9	107.80	2836	3.07	87400						
8.2	115.82	3038	2.60	87400						
6.6	144.71	3619	2.30	87350						
5.7	166.73	4144	2.06	87325						
4.2	225.50	5513	1.60	87287						
3.9	242.27	5897	1.50	87287						

S SERIES SELECTION TABLE GEARED MOTORS

3.0 kW
6 POLE

4.0 kW
4 POLE

NOTE
Other output speeds are available using 2 and 8 pole motors. Please contact our Application Engineers

N2 RPM	i	M2 Nm	Fm	N	Unit Designation	kg			
Output Speed	Ratio	Output Torque	Service Factor	Overhung Load	Column Entry 1 - 20 Spaces to be filled when entering order	Weight of Base Mount unit	Motor Size		
5.9	160.55	4062	2.09	87299	S 1 0 4 1 1 6 0 _ M _ _ _ 3 . 0 C - -	378	132S		
5.4	178.41	4494	1.84	87375	1 8 0				
4.3	222.38	5623	1.51	87299	2 1 2				
3.9	247.12	6221	1.33	87375	2 5 0				
3.5	274.67	6942	1.22	87299	2 8 0				
3.1	305.22	7680	1.08	87375	3 1 5				
2.7	358.77	9058	0.94	87299	3 6 0				
2.3	407.90	10293	0.82	87299	4 0 0				
173	8.31	192	1.09	7440	S 0 5 2 1 8 . 0 _ M _ _ _ 4 . 0 A - -	49	112M		
123	11.66	265	0.90	7440	1 1 .				
112	12.85	291	0.85	7440	1 2 .				
174	8.23	197	1.89	11851	S 0 6 2 1 8 . 0 _ M _ _ _ 4 . 0 A - -	65	112M		
124	11.57	275	1.55	11801	1 1 .				
111	12.97	308	1.45	11801	1 2 .				
99	14.56	344	1.35	11721	1 4 .				
90	15.93	346	1.49	11790	1 6 .				
78	18.49	435	1.17	11651	1 8 .				
68	20.96	491	1.08	11651	2 0 .				
64	22.40	480	1.20	11651	2 2 .				
57	25.11	534	1.11	11651	2 5 .				
51	28.18	597	1.02	11600	2 8 .				
43	33.48	772	0.81	11400	3 2 .				
40	35.79	746	0.85	11500	3 6 .				
182	7.90	193	3.19	22778	S 0 7 2 1 8 . 0 _ M _ _ _ 4 . 0 A - -			109	112M
131	10.94	267	2.75	24347	1 1 .				
117	12.29	301	2.55	24965	1 2 .				
106	13.52	329	2.41	25604	1 4 .				
91	15.80	370	1.93	26865	1 6 .				
81	17.66	428	2.05	27300	1 8 .				
71	20.07	485	1.90	28147	2 0 .				
66	21.89	509	1.53	28520	2 2 .				
58	24.59	570	1.41	28622	2 5 .				
53	27.03	626	1.31	28792	2 8 .				
47	30.81	734	1.08	28256	3 2 .				
41	35.31	810	1.08	29090	3 6 .				
36	40.15	915	0.98	29090	4 0 .				
33	44.13	1039	0.84	28990	4 5 .				
92	15.54	369	3.76	34793	S 0 8 2 1 1 6 . _ M _ _ _ 4 . 0 A - -	152	112M		
82	17.60	431	3.66	35596	1 8 .				
73	19.76	483	3.41	36798	2 0 .				
65	22.03	519	3.04	37796	2 2 .				
59	24.47	574	2.87	38426	2 5 .				
53	27.22	636	2.67	39040	2 8 .				
45	31.78	765	2.55	40031	3 2 .				
41	35.20	819	2.20	41000	3 6 .				
36	39.51	913	2.01	41143	4 0 .				
33	43.64	1040	2.09	40150	4 5 .				
29	49.26	1167	1.93	41353	5 0 .				
26	54.60	1247	1.57	41866	5 6 .				
23	63.56	1440	1.40	41832	6 3 .				
21	69.64	1628	1.53	41751	7 1 .				
19	76.50	1787	1.43	41701	8 0 .				
16	87.29	1951	1.09	41760	9 0 .				
15	98.53	2188	0.99	41800	1 0 0				
14	102.38	2368	1.17	41800	1 1 2				
12	117.89	2704	1.05	41700	1 2 5				
32	44.55	1071	3.76	53733	S 0 9 2 1 4 5 . _ M _ _ _ 4 . 0 A - -	215	112M		
29	49.49	1189	3.44	53716	5 0 .				
21	69.91	1655	2.57	53682	7 1 .				
19	77.18	1827	2.35	53653	8 0 .				
15	93.18	2089	2.25	53624	9 0 .				
14	103.53	2311	2.10	53594	1 0 0				
14	106.17	2485	1.79	53618	1 1 2				
12	119.38	2779	1.62	53573	1 2 5				
10	146.23	3200	1.65	53528	1 4 0				
8.9	161.44	3521	1.54	53482	1 6 0				
6.5	222.08	4758	1.17	53338	2 1 2				
5.7	249.73	5306	1.05	53272	2 5 0				
9.0	159.68	3550	1.35	53383	S 0 9 4 1 1 6 0 _ M _ _ _ 4 . 0 A - -	243	112M		
8.1	177.41	3927	1.23	53383	1 8 0				
6.4	224.51	4990	0.96	53383	2 1 2				
5.8	249.43	5519	0.87	53383	2 5 0				
16	91.32	2100	3.39	87400	S 1 0 2 1 9 0 . _ M _ _ _ 4 . 0 A - -	312	112M		
14	101.47	2322	3.12	87385	1 0 0				
13	107.80	2551	3.39	87400	1 1 2				
12	115.82	2733	2.92	87400	1 2 5				
10	144.71	3260	2.38	87359	1 4 0				
8.6	166.73	3732	2.13	87338	1 6 0				
6.4	225.50	4974	1.68	87332	2 1 2				
5.9	242.27	5324	1.59	87332	2 5 0				

S SERIES SELECTION TABLE GEARED MOTORS

4.0 kW
4 POLE

4.0 kW
6 POLE

N2 RPM	i	M2 Nm	Fm	N	Unit Designation	kg	
Output Speed	Ratio	Output Torque	Service Factor	Overhung Load	Column Entry <input type="text" value="1"/> - <input type="text" value="20"/> Spaces to be filled when entering order	Weight of Base Mount unit	Motor Size
8.9	160.55	3596	2.36	87299	S 1 0 4 1 1 6 0 _ M _ _ _ 4 . 0 A _ _	361	112M
8.0	178.41	3976	2.08	87375	1 8 0		
6.5	222.38	4979	1.70	87299	2 1 2		
5.8	247.12	5507	1.51	87375	2 5 0		
5.2	274.67	6149	1.38	87299	2 8 0		
4.7	305.22	6800	1.22	87375	3 1 5		
4.0	358.77	8027	1.06	87299	3 6 0		
3.5	407.90	9123	0.93	87299	4 0 0		
3.2	453.27	10090	0.82	87375	4 5 0		
117	8.23	293	1.5	11787	S 0 6 2 1 8 . 0 _ M _ _ _ 4 . 0 C _ _	86	132M
83	11.57	408	1.22	11716	1 1 .		
74	12.97	456	1.14	11646	1 2 .		
66	14.56	510	1.06	11575	1 4 .		
60	15.93	509	1.14	11646	1 6 .		
52	18.49	643	0.91	11504	1 8 .		
46	20.96	726	0.84	11433	2 0 .		
43	22.40	703	0.89	11504	2 2 .		
38	25.11	782	0.81	11433	2 5 .		
122	7.90	288	2.13	24231	S 0 7 2 1 8 . 0 _ M _ _ _ 4 . 0 C _ _	130	132M
88	10.94	398	2.13	26142	1 1 .		
78	12.29	446	2.01	26908	1 2 .		
71	13.52	489	1.89	27541	1 4 .		
61	15.80	550	1.45	28408	1 6 .		
54	17.66	635	1.61	28158	1 8 .		
48	20.07	716	1.48	28366	2 0 .		
44	21.89	754	1.14	29075	2 2 .		
39	24.59	843	1.04	29075	2 5 .		
36	27.03	923	0.97	29075	2 8 .		
87	11.01	405	3.83	33852	S 0 8 2 1 1 1 . _ M _ _ _ 4 . 0 C _ _	173	132M
78	12.24	447	3.60	34773	1 2 .		
71	13.61	494	3.38	35768	1 4 .		
62	15.54	549	2.95	37547	1 6 .		
55	17.60	636	2.88	38300	1 8 .		
49	19.76	714	2.67	39442	2 0 .		
44	22.03	771	2.31	40636	2 2 .		
39	24.47	853	2.13	40821	2 5 .		
35	27.22	944	1.97	41525	2 8 .		
30	31.78	1127	1.98	41358	3 2 .		
27	35.20	1205	1.62	41858	3 6 .		
24	39.51	1346	1.48	41816	4 0 .		
22	43.64	1539	1.60	41798	4 5 .		
19	49.26	1727	1.47	41696	5 0 .		
18	54.60	1834	1.14	41775	5 6 .		
15	63.56	2118	1.01	41712	6 3 .		
14	69.64	2412	1.15	41616	7 1 .		
13	76.50	2641	1.08	41616	8 0 .		
22	44.55	1585	2.67	53704	S 0 9 2 1 4 5 . _ M _ _ _ 4 . 0 C _ _	236	132M
19	49.49	1760	2.44	53673	5 0 .		
14	69.91	2453	1.81	53607	7 1 .		
12	77.18	2702	1.66	53559	8 0 .		
10	93.18	3064	1.71	53511	9 0 .		
9.3	103.53	3388	1.59	53462	1 0 0		
9.0	106.17	3680	1.25	53457	1 1 2		
8.0	119.38	4105	1.13	53389	1 2 5		
6.6	146.23	4698	1.19	53321	1 4 0		
5.9	161.44	5166	1.08	53252	1 6 0		
4.3	222.08	6975	0.80	53000	2 1 2		
6.0	159.68	5319	0.90	53383	S 0 9 4 1 1 6 0 _ M _ _ _ 4 . 0 C _ _	264	132M
5.4	177.41	5885	0.82	53383	1 8 0		
14	69.18	2448	3.53	87362	S 1 0 2 1 7 1 . _ M _ _ _ 4 . 0 C _ _	333	132M
12	79.71	2819	3.10	87400	8 0 .		
11	91.32	3088	2.49	87373	9 0 .		
9.5	101.47	3416	2.30	87347	1 0 0		
8.9	107.80	3762	2.31	87400	1 1 2		
8.3	115.82	4030	1.96	87400	1 2 5		
6.6	144.71	4801	1.74	87316	1 4 0		
5.8	166.73	5496	1.55	87275	1 6 0		
4.3	225.50	7312	1.21	87212	2 1 2		
4.0	242.27	7822	1.13	87212	2 5 0		
6.0	160.55	5388	1.57	87299	S 1 0 4 1 1 6 0 _ M _ _ _ 4 . 0 C _ _	382	132M
5.4	178.41	5960	1.39	87375	1 8 0		
4.3	222.38	7459	1.14	87299	2 1 2		
3.9	247.12	8252	1.00	87375	2 5 0		
3.5	274.67	9208	0.92	87299	2 8 0		
3.1	305.22	10187	0.81	87375	3 1 5		

NOTE
Other output speeds are available using 2 and 8 pole motors. Please contact our Application Engineers

S SERIES SELECTION TABLE GEARED MOTORS

5.5 kW
4 POLE

N2 RPM	i	M2 Nm	Fm	N	Unit Designation	kg	
Output Speed	Ratio	Output Torque	Service Factor	Overhung Load	Column Entry 1 - 20 Spaces to be filled when entering order	Weight of Base Mount unit	Motor Size
175	8.23	270	1.38	11786	S 0 6 2 1 8 . 0 _ M _ _ _ 5 . 5 A -	82	132S
124	11.57	377	1.13	11715	1 1 .		
111	12.97	422	1.06	11715	1 2 .		
99	14.56	472	0.99	11600	1 4 .		
90	15.93	474	1.09	11700	1 6 .		
78	18.49	596	0.85	11500	1 8 .		
64	22.40	658	0.88	11500	2 2 .		
57	25.11	732	0.81	11500	2 5 .		
182	7.90	265	2.33	22426	S 0 7 2 1 8 . 0 _ M _ _ _ 5 . 5 A -	126	132S
132	10.94	366	2.00	23887	1 1 .		
117	12.29	412	1.86	24437	1 2 .		
107	13.52	452	1.76	25025	1 4 .		
91	15.80	507	1.41	26337	1 6 .		
82	17.66	587	1.50	26550	1 8 .		
72	20.07	665	1.38	27269	2 0 .		
66	21.89	698	1.12	27954	2 2 .		
59	24.59	781	1.03	28141	2 5 .		
53	27.03	858	0.96	28452	2 8 .		
131	11.01	371	3.56	31175	S 0 8 2 1 1 1 . _ M _ _ _ 5 . 5 A -	169	132S
118	12.24	413	3.34	31897	1 2 .		
106	13.61	457	3.12	32868	1 4 .		
93	15.54	506	2.74	34371	1 6 .		
82	17.60	591	2.67	35010	1 8 .		
73	19.76	662	2.49	36130	2 0 .		
65	22.03	711	2.22	37210	2 2 .		
59	24.47	787	2.09	37782	2 5 .		
53	27.22	871	1.95	38325	2 8 .		
45	31.78	1048	1.86	38975	3 2 .		
41	35.20	1122	1.60	40250	3 6 .		
36	39.51	1251	1.47	40512	4 0 .		
33	43.64	1425	1.52	39389	4 5 .		
29	49.26	1599	1.41	41116	5 0 .		
26	54.60	1709	1.15	41837	5 6 .		
23	63.56	1973	1.02	41775	6 3 .		
21	69.64	2231	1.12	41686	7 1 .		
19	76.50	2448	1.05	41615	8 0 .		
32	44.55	1468	2.74	53698	S 0 9 2 1 4 5 . _ M _ _ _ 5 . 5 A -	232	132S
29	49.49	1629	2.51	53673	5 0 .		
21	69.91	2268	1.88	53622	7 1 .		
19	77.18	2504	1.72	53577	8 0 .		
15	93.18	2863	1.64	53533	9 0 .		
14	103.53	3167	1.53	53488	1 0 0		
14	106.17	3405	1.30	53525	1 1 2		
12	119.38	3808	1.18	53456	1 2 5		
10	146.23	4385	1.21	53387	1 4 0		
8.9	161.44	4825	1.12	53318	1 6 0		
6.5	222.08	6519	0.86	53100	2 1 2		
9.0	159.68	4865	0.98	53383	S 0 9 4 1 1 6 0 _ M _ _ _ 5 . 5 A -	260	132S
8.1	177.41	5381	0.90	53383	1 8 0		
21	69.18	2272	3.34	85716	S 1 0 2 1 7 1 . _ M _ _ _ 5 . 5 A -	329	132S
18	79.71	2606	2.94	86407	8 0 .		
16	91.32	2878	2.47	87400	9 0 .		
14	101.47	3182	2.28	87374	1 0 0		
13	107.80	3496	2.47	87400	1 1 2		
12	115.82	3745	2.13	87400	1 2 5		
10	144.71	4467	1.74	87325	1 4 0		
8.6	166.73	5114	1.56	87287	1 6 0		
6.4	225.50	6816	1.23	87275	2 1 2		
5.9	242.27	7295	1.16	87275	2 5 0		
9.0	160.55	4927	1.72	87299	S 1 0 4 1 1 6 0 _ M _ _ _ 5 . 5 A -	378	132S
8.1	178.41	5449	1.52	87375	1 8 0		
6.5	222.38	6823	1.24	87299	2 1 2		
5.8	247.12	7545	1.10	87375	2 5 0		
5.2	274.67	8425	1.01	87299	2 8 0		
4.7	305.22	9318	0.89	87375	3 1 5		

NOTE

Other output speeds are available using 2 and 8 pole motors. Please contact our Application Engineers

S SERIES SELECTION TABLE GEARED MOTORS

5.5 kW

6 POLE

N2 RPM	i	M2 Nm	Fm	N	Unit Designation	kg	
Output Speed	Ratio	Output Torque	Service Factor	Overhung Load	Column Entry 1 - 20 Spaces to be filled when entering order	Weight of Base Mount unit	Motor Size
117	8.23	403	1.09	11700	S 0 6 2 1 8 . 0 _ M _ _ _ 5 . 5 C - -	86	132M
83	11.57	561	0.89	11600	1 1 .		
74	12.97	627	0.83	11500	1 2 .		
60	15.93	700	0.83	11500	1 6 .		
122	7.90	396	1.55	23710	S 0 7 2 1 8 . 0 _ M _ _ _ 5 . 5 C - -	130	132M
88	10.94	547	1.55	25447	1 1 .		
78	12.29	613	1.46	26133	1 2 .		
71	13.52	673	1.38	26666	1 4 .		
61	15.80	756	1.05	27933	1 6 .		
54	17.66	873	1.17	27533	1 8 .		
48	20.07	984	1.08	27866	2 0 .		
44	21.89	1037	0.83	29000	2 2 .		
124	7.77	391	3.16	30947	S 0 8 2 1 8 . 0 _ M _ _ _ 5 . 5 C - -	173	132M
87	11.01	557	2.78	33284	1 1 .		
78	12.24	614	2.62	34157	1 2 .		
71	13.61	680	2.45	35089	1 4 .		
62	15.54	755	2.15	36915	1 6 .		
55	17.60	875	2.09	37400	1 8 .		
49	19.76	981	1.95	38447	2 0 .		
44	22.03	1060	1.68	39878	2 2 .		
39	24.47	1173	1.55	40173	2 5 .		
35	27.22	1298	1.43	41300	2 8 .		
30	31.78	1550	1.44	41033	3 2 .		
27	35.20	1657	1.18	41833	3 6 .		
24	39.51	1851	1.07	41766	4 0 .		
22	43.64	2117	1.16	41756	4 5 .		
19	49.26	2375	1.07	41612	5 0 .		
18	54.60	2521	0.83	41700	5 6 .		
14	69.64	3316	0.84	41500	7 1 .		
22	44.55	2179	1.95	53660	S 0 9 2 1 4 5 . _ M _ _ _ 5 . 5 C - -	236	132M
19	49.49	2420	1.77	53614	5 0 .		
14	69.91	3372	1.32	53518	7 1 .		
12	77.18	3716	1.21	53448	8 0 .		
10	93.18	4213	1.24	53377	9 0 .		
9.3	103.53	4659	1.15	53307	1 0 0 .		
9.0	106.17	5060	0.91	53300	1 1 2 .		
8.0	119.38	5645	0.82	53200	1 2 5 .		
6.6	146.23	6461	0.86	53100	1 4 0 .		
22	43.65	2160	3.76	85776	S 1 0 2 1 4 5 . _ M _ _ _ 5 . 5 C - -		
20	48.51	2395	3.47	86058	5 0 .		
14	69.18	3366	2.56	87340	7 1 .		
12	79.71	3876	2.25	87400	8 0 .		
11	91.32	4246	1.81	87357	9 0 .		
9.5	101.47	4697	1.67	87315	1 0 0 .		
8.9	107.80	5172	1.68	87400	1 1 2 .		
8.3	115.82	5542	1.43	87400	1 2 5 .		
6.6	144.71	6601	1.26	87266	1 4 0 .		
5.8	166.73	7558	1.13	87200	1 6 0 .		
4.3	225.50	10054	0.88	87100	2 1 2 .		
4.0	242.27	10756	0.82	87100	2 5 0 .		
6.0	160.55	7408	1.14	87299	S 1 0 4 1 1 6 0 _ M _ _ _ 5 . 5 C - -	382	132M
5.4	178.41	8196	1.01	87375	1 8 0 .		
4.3	222.38	10256	0.83	87299	2 1 2 .		
176	8.23	367	1.01	11700	S 0 6 2 1 8 . 0 _ M _ _ _ 7 . 5 A - -	86	132M
125	11.57	513	0.83	11600	1 1 .		
183	7.90	360	1.71	21957	S 0 7 2 1 8 . 0 _ M _ _ _ 7 . 5 A - -	130	132M
132	10.94	497	1.47	23273	1 1 .		
118	12.29	561	1.37	23732	1 2 .		
107	13.52	614	1.30	24252	1 4 .		
91	15.80	689	1.04	25632	1 6 .		
82	17.66	797	1.10	25550	1 8 .		
72	20.07	904	1.02	26100	2 0 .		
66	21.89	949	0.82	27200	2 2 .		
186	7.77	355	3.20	28647	S 0 8 2 1 8 . 0 _ M _ _ _ 7 . 5 A - -	173	132M
131	11.01	504	2.62	30675	1 1 .		
118	12.24	561	2.46	31350	1 2 .		
106	13.61	622	2.30	32243	1 4 .		
93	15.54	688	2.02	33809	1 6 .		
82	17.60	803	1.97	34229	1 8 .		
73	19.76	899	1.83	35239	2 0 .		
66	22.03	966	1.63	36429	2 2 .		
59	24.47	1070	1.54	36922	2 5 .		
53	27.22	1184	1.44	37370	2 8 .		
45	31.78	1424	1.37	37565	3 2 .		
41	35.20	1525	1.18	39250	3 6 .		
37	39.51	1701	1.08	39671	4 0 .		
33	43.64	1937	1.12	38375	4 5 .		
29	49.26	2173	1.04	40800	5 0 .		
26	54.60	2322	0.84	41800	5 6 .		
21	69.64	3032	0.82	41600	7 1 .		

7.5 kW

4 POLE

NOTE

Other output speeds are available using 2 and 8 pole motors. Please contact our Application Engineers

S SERIES SELECTION TABLE GEARED MOTORS

7.5 kW
4 POLE

7.5 kW
6 POLE

NOTE
Other output speeds are available using 2 and 8 pole motors. Please contact our Application Engineers

N2 RPM	i	M2 Nm	Fm	N	Unit Designation	kg	
Output Speed	Ratio	Output Torque	Service Factor	Overhung Load	Column Entry 1 - 20 Spaces to be filled when entering order	Weight of Base Mount unit	Motor Size
32	44.55	1995	2.02	53652	S 0 9 2 1 4 5 . _ M _ - _ _ 7 . 5 A - -	236	132M
29	49.49	2214	1.85	53616	5 0 .		
21	69.91	3082	1.38	53541	7 1 .		
19	77.18	3402	1.26	53476	8 0 .		
16	93.18	3891	1.21	53412	9 0 .		
14	103.53	4304	1.13	53347	S 0 9 2 1 1 0 0 _ M _ - _ _ 7 . 5 A - -	236	132M
14	106.17	4628	0.96	53400	1 1 2		
12	119.38	5174	0.87	53300	1 2 5		
10	146.23	5959	0.89	53200	1 4 0		
9.0	161.44	6557	0.83	53100	1 6 0		
33	43.65	1975	3.61	82939	S 1 0 2 1 4 5 . _ M _ - _ _ 7 . 5 A - -	333	132M
30	48.51	2188	3.32	83701	5 0 .		
21	69.18	3087	2.46	84696	7 1 .		
18	79.71	3541	2.17	85806	8 0 .		
16	91.32	3911	1.82	87400	9 0 .		
14	101.47	4324	1.67	87358	1 0 0		
13	107.80	4751	1.82	87400	1 1 2		
12	115.82	5089	1.57	87400	1 2 5		
10	144.71	6070	1.28	87279	1 4 0		
8.7	166.73	6949	1.15	87219	1 6 0		
6.4	225.50	9263	0.90	87200	2 1 2		
6.0	242.27	9913	0.85	87200	2 5 0		
9.0	160.55	6696	1.27	87299	S 1 0 4 1 1 6 0 _ M _ - _ _ 7 . 5 A -	-382	132M
8.1	178.41	7404	1.12	87375	1 8 0		
6.5	222.38	9272	0.91	87299	2 1 2		
5.8	247.12	10254	0.81	87375	2 5 0		
122	7.90	540	1.14	23015	S 0 7 2 1 8 . 0 _ M _ - _ _ 7 . 5 C - -	159	160M
88	10.94	746	1.14	24521	1 1 .		
78	12.29	836	1.07	25100	1 2 .		
71	13.52	918	1.01	25500	1 4 .		
54	17.66	1191	0.86	26700	1 8 .		
124	7.77	534	2.32	30421	S 0 8 2 1 8 . 0 _ M _ - _ _ 7 . 5 C - -	202	160M
87	11.01	759	2.04	32526	1 1 .		
78	12.24	838	1.92	33336	1 2 .		
71	13.61	927	1.80	34184	1 4 .		
62	15.54	1029	1.57	36073	1 6 .		
55	17.60	1193	1.53	36200	1 8 .		
49	19.76	1338	1.43	37121	2 0 .		
44	22.03	1446	1.23	38868	2 2 .		
39	24.47	1600	1.14	39310	2 5 .		
35	27.22	1770	1.05	41000	2 8 .		
30	31.78	2114	1.05	40600	3 2 .		
27	35.20	2260	0.86	41800	3 6 .		
22	43.64	2887	0.85	41700	4 5 .		
87	10.98	760	3.73	51500	S 0 9 2 1 1 1 . _ M _ - _ _ 7 . 5 C - -	265	160M
78	12.30	850	3.49	52800	1 2 .		
70	13.81	952	3.25	53800	1 4 .		
58	16.68	1108	2.73	53800	1 6 .		
54	17.79	1220	2.79	53800	1 8 .		
48	19.88	1357	2.60	53800	2 0 .		
42	22.96	1513	2.25	53800	2 2 .		
37	25.73	1685	2.11	53800	2 5 .		
33	28.89	1887	1.96	53800	2 8 .		
31	31.43	2119	1.92	53800	3 2 .		
26	37.22	2398	1.68	53800	3 6 .		
23	41.59	2679	1.56	53700	4 0 .		
22	44.55	2971	1.43	53602	4 5 .		
19	49.49	3300	1.30	53536	5 0 .		
17	57.66	3647	1.27	53600	5 6 .		
15	65.74	4129	1.16	53500	6 3 .		
14	69.91	4599	0.97	53400	7 1 .		
12	77.18	5067	0.88	53300	8 0 .		
10	93.18	5745	0.91	53200	9 0 .		
9.3	103.53	6354	0.85	53100	1 0 0		
41	23.23	1554	3.84	79500	S 1 0 2 1 2 2 . _ M _ - _ _ 7 . 5 C - -	362	160M
38	25.27	1682	3.61	81400	2 5 .		
33	28.70	1902	3.28	84200	2 8 .		
30	31.85	2167	3.40	85000	3 2 .		
26	37.38	2463	2.67	87400	3 6 .		
24	40.36	2642	2.52	87400	4 0 .		
22	43.65	2945	2.76	84964	4 5 .		
20	48.51	3267	2.55	85388	5 0 .		
16	58.85	3798	1.87	87400	5 6 .		
14	66.62	4303	1.68	87400	6 3 .		
14	69.18	4590	1.88	87311	7 1 .		
12	79.71	5286	1.65	87400	8 0 .		
11	91.32	5790	1.33	87336	9 0 .		

S SERIES SELECTION TABLE GEARED MOTORS

7.5 kW
6 POLE

11.0 kW
4 POLE

N2 RPM	i	M2 Nm	Fm	N	Unit Designation	kg	
Output Speed	Ratio	Output Torque	Service Factor	Overhung Load	Column Entry 1 - 20 Spaces to be filled when entering order	Weight of Base Mount unit	Motor Size
9.5	101.47	6405	1.22	87273	S 1 0 2 1 1 0 0 _ M _ _ _ 7 . 5 C _ _	362	160M
8.9	107.80	7054	1.23	87400	1 1 2		
8.3	115.82	7557	1.05	87400	1 2 5		
6.6	144.71	9002	0.93	87200	1 4 0		
5.8	166.73	10306	0.83	87100	1 6 0		
6.0	160.55	10103	0.84	87299	S 1 0 4 1 1 6 0 _ M _ _ _ 7 . 5 C _ _	411	160M
184	7.90	526	1.17	21137	S 0 7 2 1 8 . 0 _ M _ _ _ 1 1 . A _ _	159	160M
132	10.94	727	1.01	22200	1 1 .		
118	12.29	820	0.94	22500	1 2 .		
107	13.52	898	0.89	22900	1 4 .		
187	7.77	520	2.19	28018	S 0 8 2 1 8 . 0 _ M _ _ _ 1 1 . A _ _	202	160M
132	11.01	737	1.79	29800	1 1 .		
119	12.24	820	1.68	30393	1 2 .		
107	13.61	909	1.57	31150	1 4 .		
93	15.54	1005	1.38	32825	1 6 .		
82	17.60	1174	1.35	32862	1 8 .		
73	19.76	1315	1.25	33681	2 0 .		
66	22.03	1413	1.12	35062	2 2 .		
59	24.47	1564	1.05	35418	2 5 .		
53	27.22	1731	0.98	35700	2 8 .		
46	31.78	2082	0.94	35100	3 2 .		
41	35.20	2229	0.81	37500	3 6 .		
182	7.97	539	3.93	44500	S 0 9 2 1 8 . 0 _ M _ _ _ 1 1 . A _ _	265	160M
132	10.98	741	3.26	47600	1 1 .		
118	12.30	831	3.05	48700	1 2 .		
105	13.81	928	2.85	50100	1 4 .		
87	16.68	1075	2.40	53100	1 6 .		
81	17.79	1194	2.45	53300	1 8 .		
73	19.88	1326	2.29	53800	2 0 .		
63	22.96	1473	1.98	53800	2 2 .		
56	25.73	1652	1.85	53800	2 5 .		
50	28.89	1841	1.73	53800	2 8 .		
46	31.43	2078	1.73	53800	3 2 .		
39	37.22	2355	1.48	53800	3 6 .		
35	41.59	2634	1.38	53700	4 0 .		
33	44.55	2916	1.38	53572	4 5 .		
29	49.49	3236	1.26	53515	5 0 .		
25	57.66	3601	1.13	53600	5 6 .		
22	65.74	4091	1.04	53500	6 3 .		
21	69.91	4505	0.95	53400	7 1 .		
19	77.18	4973	0.86	53300	8 0 .		
16	93.18	5687	0.83	53200	9 0 .		
62	23.23	1520	3.55	73000	S 1 0 2 1 2 2 . _ M _ _ _ 1 1 . A _ _	362	160M
57	25.27	1651	3.35	74000	2 5 .		
51	28.70	1869	3.05	75400	2 8 .		
46	31.85	2126	3.01	75100	3 2 .		
39	37.38	2424	2.50	79400	3 6 .		
36	40.36	2601	2.36	81000	4 0 .		
33	43.65	2887	2.47	80522	4 5 .		
30	48.51	3198	2.27	81258	5 0 .		
25	58.85	3753	1.76	87400	5 6 .		
22	66.62	4231	1.60	87400	6 3 .		
21	69.18	4512	1.68	82911	7 1 .		
18	79.71	5176	1.48	84754	8 0 .		
16	91.32	5716	1.25	87400	9 0 .		
14	101.47	6320	1.15	87331	1 0 0		
13	107.80	6945	1.25	87400	1 1 2		
13	115.82	7438	1.07	87400	1 2 5		
10	144.71	8873	0.87	87200	1 4 0		
9.0	160.55	9787	0.87	87299	S 1 0 4 1 1 6 0 _ M _ _ _ 1 1 . A _ _	411	160M

NOTE

Other output speeds are available using 2 and 8 pole motors. Please contact our Application Engineers

S SERIES SELECTION TABLE GEARED MOTORS

11.0 kW
6 POLE

N2 RPM	i	M2 Nm	Fm	N	Unit Designation	kg	
Output Speed	Ratio	Output Torque	Service Factor	Overhung Load	Column Entry 1 - 20 Spaces to be filled when entering order	Weight of Base Mount unit	Motor Size
124	7.77	779	1.59	29500	S 0 8 2 1 8 . 0 _ M _ _ _ 1 1 . C -	216	160L
88	11.01	1108	1.40	31200	1 1 .		
79	12.24	1223	1.32	31900	1 2 .		
71	13.61	1353	1.23	32600	S 0 8 2 1 1 4 . _ M _ _ _ 1 1 . C -	216	160L
62	15.54	1502	1.08	34600	1 6 .		
55	17.60	1741	1.05	34100	1 8 .		
49	19.76	1953	0.98	34800	2 0 .		
44	22.03	2110	0.84	37100	2 2 .		
121	7.97	807	3.11	47360	S 0 9 2 1 8 . 0 _ M _ _ _ 1 1 . C -	279	160L
88	10.98	1109	2.56	50348	1 1 .		
78	12.30	1240	2.39	51508	1 2 .		
70	13.81	1390	2.23	52446	1 4 .		
58	16.68	1617	1.87	53510	1 6 .		
54	17.79	1780	1.91	52931	1 8 .		
49	19.88	1980	1.78	53124	2 0 .		
42	22.96	2208	1.54	53703	2 2 .		
37	25.73	2458	1.44	53704	2 5 .		
33	28.89	2754	1.34	53672	2 8 .		
31	31.43	3092	1.32	53640	3 2 .		
26	37.22	3500	1.15	53613	3 6 .		
23	41.59	3909	1.07	53513	4 0 .		
22	44.55	4336	0.98	53500	4 5 .		
19	49.49	4814	0.89	53400	5 0 .		
17	57.66	5321	0.87	53300	5 6 .		
70	13.72	1391	3.94	67833	S 1 0 2 1 1 4 . _ M _ _ _ 1 1 . C -	376	160L
58	16.63	1635	3.38	71873	1 6 .		
54	17.87	1802	3.34	72391	1 8 .		
50	19.29	1944	3.19	74166	2 0 .		
42	23.23	2268	2.63	78084	2 2 .		
38	25.27	2455	2.48	79860	2 5 .		
34	28.70	2775	2.25	82457	2 8 .		
30	31.85	3162	2.33	82340	3 2 .		
26	37.38	3594	1.83	85855	3 6 .		
24	40.36	3856	1.73	86144	4 0 .		
22	43.65	4297	1.89	83544	4 5 .		
20	48.51	4766	1.75	84214	5 0 .		
16	58.85	5541	1.28	87336	5 6 .		
14	66.62	6279	1.15	87353	6 3 .		
14	69.18	6697	1.29	87259	7 1 .		
12	79.71	7713	1.13	87400	8 0 .		
11	91.32	8448	0.91	87300	9 0 .		
10	101.47	9345	0.84	87200	1 0 0		
184	7.90	716	0.86	20200	S 0 7 2 1 8 . 0 _ M _ _ _ 1 5 . A - -	173	160L
187	7.77	707	1.61	27300	S 0 8 2 1 8 . 0 _ M _ _ _ 1 5 . A - -	216	160L
132	11.01	1001	1.32	28800	1 1 .		
119	12.24	1115	1.24	29300	1 2 .		
107	13.61	1235	1.16	29900	1 4 .		
94	15.54	1366	1.02	31700	1 6 .		
83	17.60	1595	0.99	31300	1 8 .		
74	19.76	1787	0.92	31900	2 0 .		
66	22.03	1920	0.82	33500	2 2 .		
182	7.97	733	2.89	43852	S 0 9 2 1 8 . 0 _ M _ _ _ 1 5 . A - -	279	160L
133	10.98	1007	2.4	46717	1 1 .		
118	12.30	1130	2.25	47715	1 2 .		
105	13.81	1261	2.1	49007	1 4 .		
87	16.68	1460	1.77	52131	1 6 .		
82	17.79	1622	1.8	51889	1 8 .		
73	19.88	1803	1.69	52636	2 0 .		
63	22.96	2002	1.46	53727	2 2 .		
57	25.73	2245	1.36	53727	2 5 .		
50	28.89	2501	1.27	53727	2 8 .		
46	31.43	2824	1.27	53586	3 2 .		
39	37.22	3200	1.09	53640	3 6 .		
35	41.59	3579	1.02	53540	4 0 .		
33	44.55	3963	1.02	53480	4 5 .		
29	49.49	4398	0.93	53400	5 0 .		
25	57.66	4894	0.83	53400	5 6 .		
120	12.08	1116	3.99	60823	S 1 0 2 1 1 2 . _ M _ _ _ 1 5 . A - -	376	160L
106	13.72	1265	3.7	62817	1 4 .		
87	16.63	1482	3.19	66523	1 6 .		
81	17.87	1640	3.16	67047	1 8 .		
75	19.29	1766	3.02	68664	2 0 .		
63	23.23	2065	2.61	71917	2 2 .		
58	25.27	2244	2.47	72823	2 5 .		
51	28.70	2540	2.25	74061	2 8 .		
46	31.85	2890	2.21	73069	3 2 .		

NOTE

Other output speeds are available using 2 and 8 pole motors. Please contact our Application Engineers

S SERIES SELECTION TABLE GEARED MOTORS

15.0 kW
4 POLE

15.0 kW
6 POLE

18.5 kW
4 POLE

N2 RPM	i	M2 Nm	Fm	N	Unit Designation	kg			
Output Speed	Ratio	Output Torque	Service Factor	Overhung Load	Column Entry 1 - 20 Spaces to be filled when entering order	Weight of Base Mount unit	Motor Size		
39	37.38	3294	1.84	77673	S 1 0 2 1 3 6 . _ M _ - _ _ 1 5 . A - -	376	160L		
36	40.36	3535	1.74	79147	4 0 .				
33	43.65	3923	1.82	77759	4 5 .				
30	48.51	4347	1.67	78467	5 0 .				
25	58.85	5100	1.30	85327	5 6 .				
22	66.62	5750	1.18	85945	6 3 .				
21	69.18	6132	1.24	80870	7 1 .				
18	79.71	7034	1.09	83552	8 0 .				
16	91.32	7768	0.92	87400	9 0 .				
14	101.47	8589	0.84	87300	1 0 0				
122	7.97	1095	2.29	46400	S 0 9 2 1 8 . 0 _ M _ - _ _ 1 5 . C - -			365	180L
88	10.98	1505	1.89	49033	1 1 .				
79	12.30	1682	1.76	50033	1 2 .				
70	13.81	1886	1.64	50900	1 4 .				
58	16.68	2194	1.38	53179	1 6 .				
55	17.79	2415	1.41	51937	1 8 .				
49	19.88	2687	1.31	52351	2 0 .				
42	22.96	2995	1.14	53593	2 2 .				
38	25.73	3335	1.06	53595	2 5 .				
34	28.89	3736	0.99	53527	2 8 .				
31	31.43	4195	0.97	53459	3 2 .				
26	37.22	4748	0.85	53400	3 6 .				
122	7.95	1100	3.49	59266	S 1 0 2 1 8 . 0 _ M _ - _ _ 1 5 . C - -	462	180L		
87	11.11	1533	3.30	63366	1 1 .				
80	12.08	1666	3.13	64500	1 2 .				
71	13.72	1887	2.90	66500	1 4 .				
58	16.63	2218	2.49	70700	1 6 .				
54	17.87	2445	2.47	70666	1 8 .				
50	19.29	2637	2.35	72300	2 0 .				
42	23.23	3077	1.94	76466	2 2 .				
38	25.27	3330	1.83	78100	2 5 .				
34	28.70	3765	1.66	80466	2 8 .				
30	31.85	4290	1.72	79300	3 2 .				
26	37.38	4876	1.35	84089	3 6 .				
24	40.36	5231	1.27	84710	4 0 .				
22	43.65	5830	1.39	81920	4 5 .				
20	48.51	6466	1.29	82873	5 0 .				
16	58.85	7518	0.94	87263	5 6 .				
15	66.62	8518	0.85	87300	6 3 .				
14	69.18	9086	0.95	87200	7 1 .				
184	7.97	895	2.37	43286	S 0 9 2 1 8 . 0 _ M _ - _ _ 1 8 . A - -	351	180M		
134	10.98	1230	1.97	45945	1 1 .				
119	12.30	1379	1.84	46853	1 2 .				
106	13.81	1540	1.72	48051	1 4 .				
88	16.68	1783	1.45	51284	1 6 .				
83	17.79	1980	1.47	50655	1 8 .				
74	19.88	2201	1.38	51618	2 0 .				
64	22.96	2444	1.19	53663	2 2 .				
57	25.73	2741	1.11	53663	2 5 .				
51	28.89	3054	1.04	53663	2 8 .				
47	31.43	3447	1.04	53400	3 2 .				
39	37.22	3907	0.89	53500	3 6 .				
35	41.59	4369	0.83	53400	4 0 .				
33	44.55	4838	0.83	53400	4 5 .				
132	11.11	1251	3.44	59054	S 1 0 2 1 1 1 . _ M _ - _ _ 1 8 . A - -			448	180M
122	12.08	1362	3.27	60144	1 2 .				
107	13.72	1544	3.03	62045	1 4 .				
88	16.63	1809	2.61	65844	1 6 .				
82	17.87	2002	2.59	66038	1 8 .				
76	19.29	2156	2.47	67583	2 0 .				
63	23.23	2522	2.14	70970	2 2 .				
58	25.27	2739	2.02	71794	2 5 .				
51	28.70	3101	1.84	72890	2 8 .				
46	31.85	3528	1.81	71292	3 2 .				
39	37.38	4021	1.51	76163	3 6 .				
36	40.36	4316	1.42	77526	4 0 .				

NOTE

Other output speeds are available using 2 and 8 pole motors. Please contact our Application Engineers

S SERIES SELECTION TABLE GEARED MOTORS

18.5 kW
4 POLE

18.5 kW
6 POLE

22.0 kW
4 POLE

22.0 kW
6 POLE

NOTE

Other output speeds are available using 2 and 8 pole motors. Please contact our Application Engineers

N2 RPM	i	M2 Nm	Fm	N	Unit Designation	kg			
Output Speed	Ratio	Output Torque	Service Factor	Overhung Load	Column Entry 1 - 20 Spaces to be filled when entering order	Weight of Base Mount unit	Motor Size		
34	43.65	4790	1.49	75342	S 1 0 2 1 4 5 . _ M _ _ _ 1 8 . A _ _	448	180M		
30	48.51	5306	1.37	76025	5 0 .				
25	58.85	6226	1.06	83513	5 6 .				
22	66.62	7019	0.96	84672	6 3 .				
21	69.18	7486	1.01	79085	7 1 .				
18	79.71	8586	0.89	82500	8 0 .				
122	7.97	1344	1.87	45560	S 0 9 2 1 8 . 0 _ M _ _ _ 1 8 . C _ _	423	200L		
89	10.98	1847	1.54	47882	1 1 .				
79	12.30	2064	1.44	48742	1 2 .				
71	13.81	2314	1.34	49546	1 4 .				
58	16.68	2692	1.13	52889	1 6 .				
55	17.79	2963	1.15	51068	1 8 .				
49	19.88	3297	1.07	51675	2 0 .				
42	22.96	3675	0.93	53496	2 2 .				
38	25.73	4092	0.87	53500	2 5 .				
34	28.89	4584	0.81	53400	2 8 .				
123	7.95	1350	2.84	58597	S 1 0 2 1 8 . 0 _ M _ _ _ 1 8 . C _ _			522	200L
88	11.11	1881	2.69	62417	1 1 .				
81	12.08	2044	2.55	63473	1 2 .				
71	13.72	2316	2.37	65333	1 4 .				
59	16.63	2722	2.03	69673	1 6 .				
55	17.87	3001	2.01	69157	1 8 .				
51	19.29	3235	1.92	70666	2 0 .				
42	23.23	3775	1.58	75051	2 2 .				
39	25.27	4086	1.49	76560	2 5 .				
34	28.70	4620	1.35	78724	2 8 .				
31	31.85	5264	1.40	76640	3 2 .				
26	37.38	5983	1.10	82544	3 6 .				
24	40.36	6418	1.04	83455	4 0 .				
184	7.97	1064	1.99	42720	S 0 9 2 1 8 . 0 _ M _ _ _ 2 2 . A _ _	365	180L		
134	10.98	1462	1.65	45173	1 1 .				
119	12.30	1640	1.55	45992	1 2 .				
106	13.81	1831	1.45	47096	1 4 .				
88	16.68	2120	1.22	50436	1 6 .				
83	17.79	2355	1.24	49421	1 8 .				
74	19.88	2617	1.16	50600	2 0 .				
64	22.96	2906	1.00	53600	2 2 .				
57	25.73	3260	0.94	53600	2 5 .				
51	28.89	3632	0.88	53600	2 8 .				
185	7.95	1066	3.50	54676	S 1 0 2 1 8 . 0 _ M _ _ _ 2 2 . A _ _			462	180L
132	11.11	1488	2.89	58426	1 1 .				
122	12.08	1620	2.75	59464	1 2 .				
107	13.72	1836	2.55	61273	1 4 .				
88	16.63	2151	2.20	65164	1 6 .				
82	17.87	2381	2.18	65029	1 8 .				
76	19.29	2564	2.08	66502	2 0 .				
63	23.23	2999	1.80	70023	2 2 .				
58	25.27	3258	1.70	70764	2 5 .				
51	28.70	3687	1.55	71719	2 8 .				
46	31.85	4195	1.53	69515	3 2 .				
39	37.38	4782	1.27	74652	3 6 .				
36	40.36	5133	1.20	75905	4 0 .				
34	43.65	5696	1.25	72925	4 5 .				
30	48.51	6310	1.15	73582	5 0 .				
25	58.85	7405	0.89	81700	5 6 .				
22	66.62	8347	0.81	83400	6 3 .				
21	69.18	8903	0.85	77300	7 1 .				
122	7.97	1599	1.57	44720	S 0 9 2 1 8 . 0 _ M _ _ _ 2 2 . C _ _	423	200L		
89	10.98	2197	1.29	46731	1 1 .				
79	12.30	2455	1.21	47451	1 2 .				
71	13.81	2752	1.13	48193	1 4 .				
58	16.68	3201	0.95	52600	1 6 .				
55	17.79	3523	0.96	50200	1 8 .				
49	19.88	3921	0.90	51000	2 0 .				
123	7.95	1605	2.39	57928	S 1 0 2 1 8 . 0 _ M _ _ _ 2 2 . C _ _			522	200L
88	11.11	2236	2.26	61468	1 1 .				
81	12.08	2431	2.15	62446	1 2 .				
71	13.72	2754	1.99	64166	1 4 .				
59	16.63	3237	1.71	68646	1 6 .				
55	17.87	3568	1.69	67648	1 8 .				
51	19.29	3848	1.61	69033	2 0 .				
42	23.23	4490	1.33	73635	2 2 .				
39	25.27	4859	1.25	75020	2 5 .				
34	28.70	5494	1.14	76982	2 8 .				
31	31.85	6260	1.18	73980	3 2 .				
26	37.38	7115	0.92	81000	3 6 .				
24	40.36	7633	0.87	82200	4 0 .				

S SERIES SELECTION TABLE GEARED MOTORS

30.0 kW
4 POLE

30.0 kW
6 POLE

37.0 kW
4 POLE

45.0 kW
4 POLE

N2 RPM	i	M2 Nm	Fm	N	Unit Designation	kg	
Output Speed	Ratio	Output Torque	Service Factor	Overhung Load	Column Entry 1 - 20 Spaces to be filled when entering order	Weight of Base Mount unit	Motor Size
184	7.97	1452	1.46	41426	S 0 9 2 1 8 . 0 _ M _ - _ _ 3 0 . A -	423	200L
134	10.98	1994	1.21	43408	1 1 .		
119	12.30	2237	1.14	44023	1 2 .		
106	13.81	2497	1.06	44911	1 4 .		
88	16.68	2891	0.89	48500	1 6 .		
83	17.79	3212	0.91	46600	1 8 .		
185	7.95	1454	2.56	53641	S 1 0 2 1 8 . 0 _ M _ - _ _ 3 0 . A -	522	200L
132	11.11	2029	2.12	56991	1 1 .		
122	12.08	2209	2.01	57911	1 2 .		
107	13.72	2504	1.87	59508	1 4 .		
88	16.63	2934	1.61	63611	1 6 .		
82	17.87	3247	1.60	62723	1 8 .		
76	19.29	3497	1.52	64032	2 0 .		
63	23.23	4089	1.32	67858	2 2 .		
58	25.27	4442	1.25	68411	2 5 .		
51	28.70	5028	1.14	69042	2 8 .		
46	31.85	5721	1.12	65453	3 2 .		
39	37.38	6520	0.93	71200	3 6 .		
36	40.36	6999	0.88	72200	4 0 .		
123	7.97	2169	1.16	42800	S 0 9 2 1 8 . 0 _ M _ - _ _ 3 0 . C -	513	225M
89	10.98	2980	0.95	44100	1 1 .		
80	12.30	3331	0.89	44500	1 2 .		
71	13.81	3733	0.83	45100	1 4 .		
123	7.95	2178	1.76	56400	S 1 0 2 1 8 . 0 _ M _ - _ _ 3 0 . C -	612	225M
88	11.11	3034	1.67	59300	1 1 .		
81	12.08	3299	1.58	60100	1 2 .		
71	13.72	3736	1.47	61500	1 4 .		
59	16.63	4392	1.26	66300	1 6 .		
55	17.87	4841	1.25	64200	1 8 .		
51	19.29	5220	1.19	65300	2 0 .		
42	23.23	6091	0.98	70400	2 2 .		
39	25.27	6593	0.92	71500	2 5 .		
34	28.70	7454	0.84	73000	2 8 .		
31	31.85	8493	0.87	67900	3 2 .		
185	7.97	1784	1.19	40294	S 0 9 2 1 8 . 0 _ M _ - _ _ 3 7 . A -	478	225S
134	10.98	2451	0.99	41864	1 1 .		
120	12.30	2749	0.92	42300	1 2 .		
107	13.81	3069	0.86	43000	1 4 .		
186	7.95	1787	2.09	52735	S 1 0 2 1 8 . 0 _ M _ - _ _ 3 7 . A -	577	225S
133	11.11	2494	1.72	55735	1 1 .		
122	12.08	2715	1.64	56552	1 2 .		
108	13.72	3078	1.52	57964	1 4 .		
89	16.63	3606	1.31	62252	1 6 .		
83	17.87	3991	1.30	60705	1 8 .		
76	19.29	4298	1.24	61870	2 0 .		
63	23.23	5026	1.07	65964	2 2 .		
58	25.27	5460	1.01	66352	2 5 .		
51	28.70	6181	0.92	66700	2 8 .		
46	31.85	7032	0.91	61900	3 2 .		
185	7.97	2170	0.98	39000	S 0 9 2 1 8 . 0 _ M _ - _ _ 4 5 . A -	513	225M
134	10.98	2982	0.81	40100	1 1 .		
186	7.95	2173	1.72	51700	S 1 0 2 1 8 . 0 _ M _ - _ _ 4 5 . A -	612	225M
133	11.11	3033	1.42	54300	1 1 .		
122	12.08	3302	1.35	55000	1 2 .		
108	13.72	3743	1.25	56200	1 4 .		
89	16.63	4386	1.08	60700	1 6 .		
83	17.87	4854	1.07	58400	1 8 .		
76	19.29	5228	1.02	59400	2 0 .		
63	23.23	6113	0.88	63800	2 2 .		
58	25.27	6641	0.83	64000	2 5 .		

NOTE

Other output speeds are available using 2 and 8 pole motors. Please contact our Application Engineers

S SERIES

DIMENSIONS

DOUBLE REDUCTION

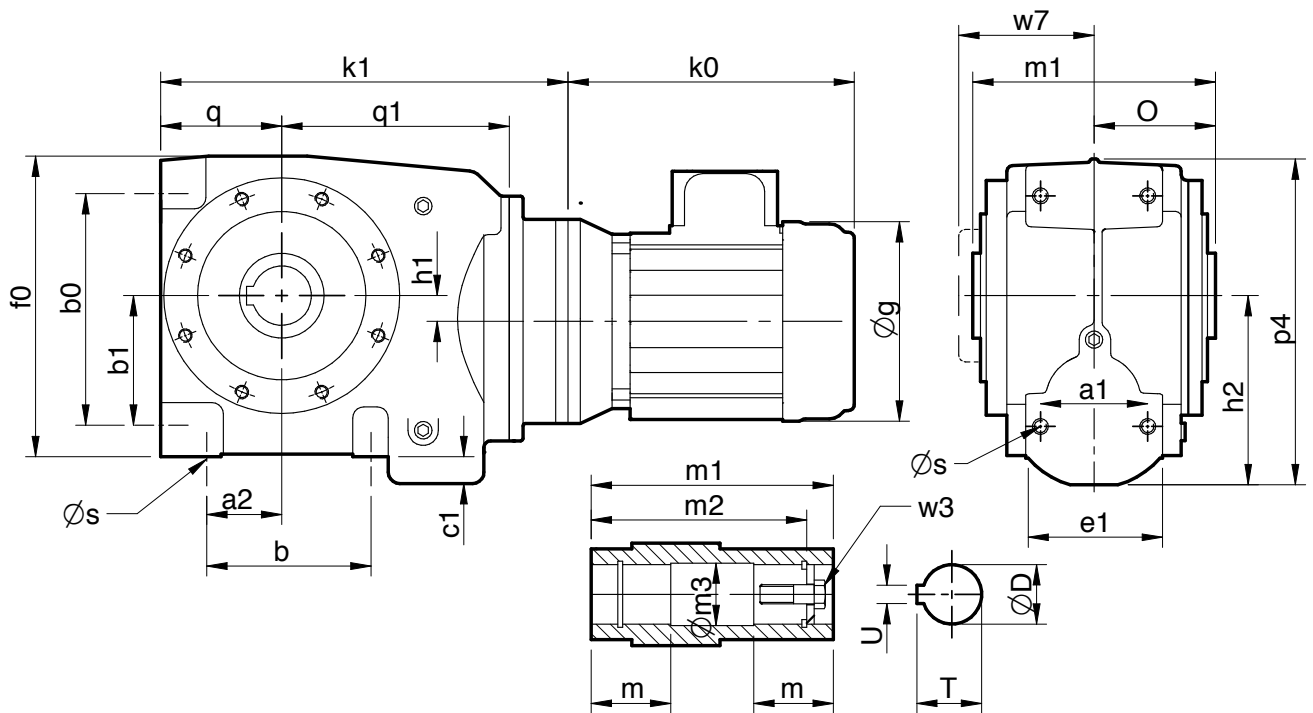

Size	a1	a2	b	b0	b1	c1	e1	f0	h1	h2	o	p4	q	q1
S0321	54	35	63	80	40	9	70	139	5.3	79.5	62	148	54	109
S0421	56	35	80	118	65	7	80	158	15	93	65	168	64	119
S0521	68	45	100	142	77	16	86	177	13	112	70	200	68	134
S0621	80	56	122	172	96	20	102	218	17	139.5	90	243	90	169

Size	s	w7	D	m	m1	m2	m3	T	U	w3
S0321	M8 x 1.25 x 15	70	20	52	124	104	20.2	22.9	6	M6 x 1.0 x 40
S0421	M10 x 1.5 x 20	74.5	30	54	130	122	30.2	33.5	8	M10 x 1.5 x 50
S0521	M10 x 1.5 x 18	79	35	56	140	127	35.3	38.5	10	M12 x 1.75 x 55
S0621	M12 x 1.75 x 20	101	45	70	180	156	45.3	49	14	M16 x 2.0 x 70

Size	S0321						S0421						S0521						S0621					
	k0	g	k1	k1	k1	k1	k0	g	k1	k1	k1	k1	k0	g	k1	k1	k1	k1	k0	g	k1	k1	k1	k1
63	195	125	197	217	236	271	195	125	197	217	236	271	195	125	197	217	236	271	195	125	197	217	236	271
71	220	140	201	221	240	277	220	140	201	221	240	277	220	140	201	221	240	277	220	140	201	221	240	277
80	240	160	214	234	253	295	240	160	214	234	253	295	240	160	214	234	253	295	240	160	214	234	253	295
90S	260	180	224	244	263	305	260	180	224	244	263	305	260	180	224	244	263	305	260	180	224	244	263	305
90L	280	180	224	244	263	305	280	180	224	244	263	305	280	180	224	244	263	305	280	180	224	244	263	305
100L	310	200	232	252	271	332	310	200	232	252	271	332	310	200	232	252	271	332	310	200	232	252	271	332
112M	330	225	232	252	271	332	330	225	232	252	271	332	330	225	232	252	271	332	330	225	232	252	271	332
132S	380	260	-	-	-	332	380	260	-	-	-	332	380	260	-	-	-	332	380	260	-	-	-	332
132M	420	260	-	-	-	332	420	260	-	-	-	332	420	260	-	-	-	332	420	260	-	-	-	332

S SERIES DIMENSIONS DOUBLE REDUCTION

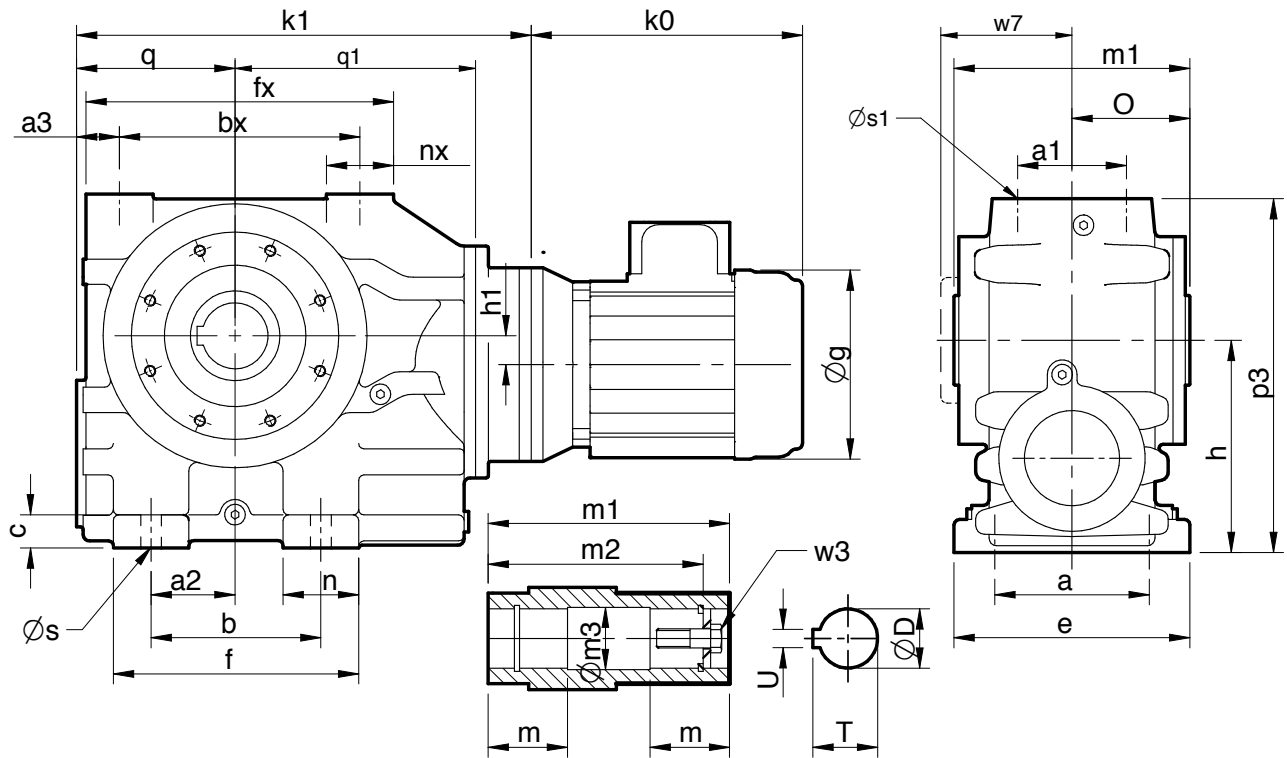

Size	a	a1	a2	a3	b	bx	c	e	f	fx	h	h1	n	nx	o	p3	q	q1
S0721	150	100	75	35.5	135	215	28	185	202	280	180	26	67	63	109	302	143	220
S0821	200	120	92	43	180	250	35	250	260	326	225	28	80	71	125	375	168	255
S0921	250	135	115	50	235	290	40	305	320	380	280	40	85	85	150	457	195	300
S1021	300	150	170	62.5	310	345	45	360	420	460	335	65	110	107	175	565	235	355

Size	s	s1	w7	D	m	m1	m2	m3	T	U	w3
S0721	18	M20 x 2.5 x 34	125	60	79	218	188	60.5	64.6	18	M20 x 2.5, 80
S0821	22	M20 x 2.5 x 34	143	70	90	250	220	70.5	75.1	20	M20 x 2.5, 80
S0921	26	M24 x 3.0 x 45	169	90	107.5	300	265	90.5	95.6	25	M24 x 3.0 x 110
S1021	26	M24 x 3.0 x 45	198	100	132.5	350	313	100.5	106.6	28	M24 x 3.0 x 110

Size			S0721	S0821	S0921	S1021
	k0	g	k1	k1	k1	k1
80	240	160	400	505	553	-
90S	260	180	410	505	553	-
90L	280	180	410	505	553	-
100L	310	200	422	511	559	637
112M	330	225	422	511	559	637
132S	380	260	444	511	559	637
132M	420	260	444	511	559	637
160M	480	320	452	541	594	672
160L	530	320	452	541	594	672
180M	560	360	-	-	594	672
180L	595	360	-	-	594	672
200L	660	400	-	-	594	672
225S	680	450	-	-	621	699
225M	725	450	-	-	621	699

S SERIES

DIMENSIONS

TRIPLE REDUCTION

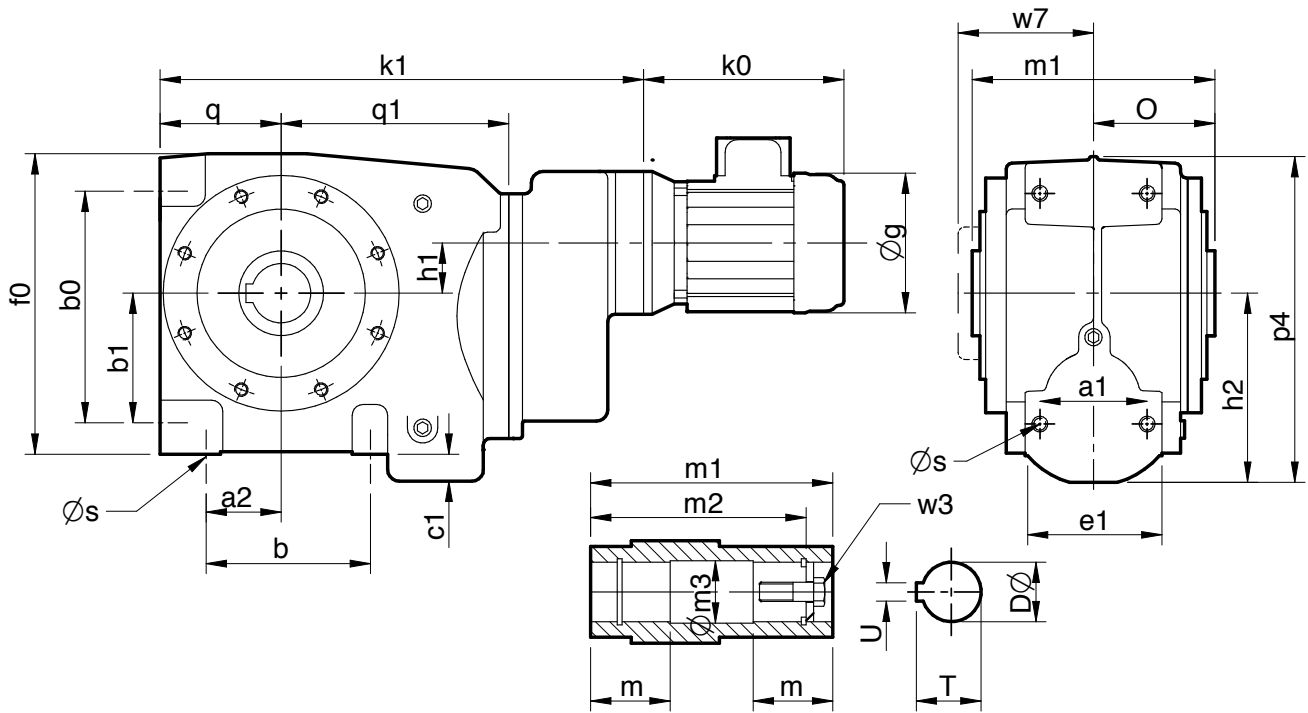

Size	a1	a2	b	b0	b1	c1	e1	f0	h1	h2	o	p4	q	q1
S0331	54	35	63	80	40	9	70	139	30.75	79.5	62	148	54	109
S0431	56	35	80	118	65	7	80	158	21.2	93	65	168	64	119
S0531	68	46	100	142	77	16	86	177	23	112	70	200	68	134
S0631	80	56	122	172	96	20	102	218	30	139.5	90	243	90	169

Size	s	w7	D	m	m1	m2	m3	T	U	w3
S0331	M8 x 1.25 x 15	70	20	52	124	104	20.2	22.9	6	M6 x 1.0 x 40
S0431	M10 x 1.5 x 18	74.5	30	54	130	122	30.2	33.5	8	M10 x 1.5 x 50
S0531	M10 x 1.5 x 18	79	35	56	140	127	35.3	38.5	10	M12 x 1.75 x 55
S0631	M12 x 1.75 x 20	101	45	70	180	156	45.3	49	14	M16 x 2.0 x 70

Size			S0331	S0431	S0531	S0631
	k0	g	k1	k1	k1	k1
63	195	125	253	273	292	359
71	220	140	257	277	296	363
80	240	160	270	290	309	376
90S	260	180	280	300	319	386
90L	280	180	280	300	319	386
100L	310	200	288	308	327	394
112M	330	225	288	308	327	394

S SERIES

DIMENSIONS

TRIPLE REDUCTION

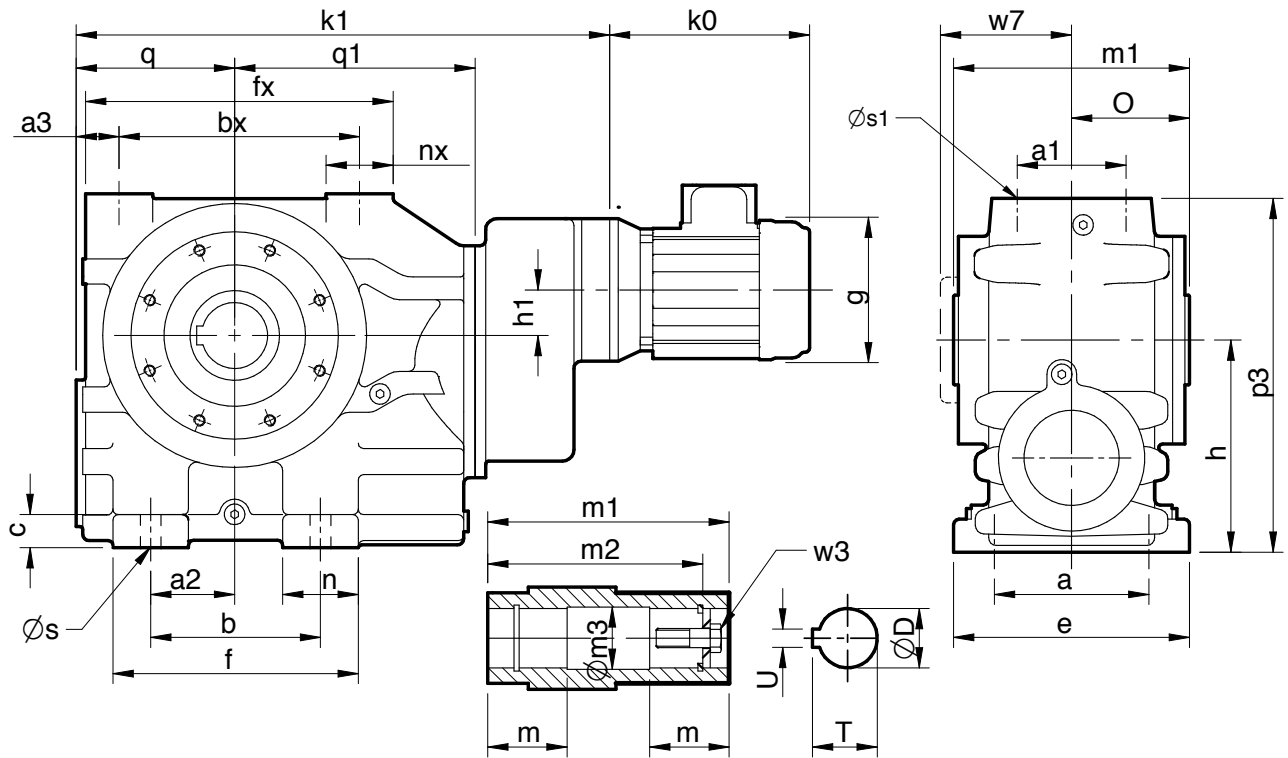

Size	a	a1	a2	a3	b	bx	c	e	f	fx	h	h1	n	nx	o	p3	q	q1
S0731	150	100	75	35.5	135	215	28	185	202	280	180	34	67	63	109	302	143	220

Size	s	s1	w7	D	m	m1	m2	m3	T	U	w3
S0731	18	M20 x 2.5 x 34	125	60	79	218	188	60.5	64.6	18	M20 x 2.5 x 80

Size	S0721		
	k0	g	k1
63	195	125	461
71	220	140	467
80	240	160	485
90S	260	180	495
90L	280	180	495
100L	310	200	522
112M	330	225	522
132S	380	260	522
132M	420	260	522

S SERIES

DIMENSIONS

QUADRUPLE REDUCTION

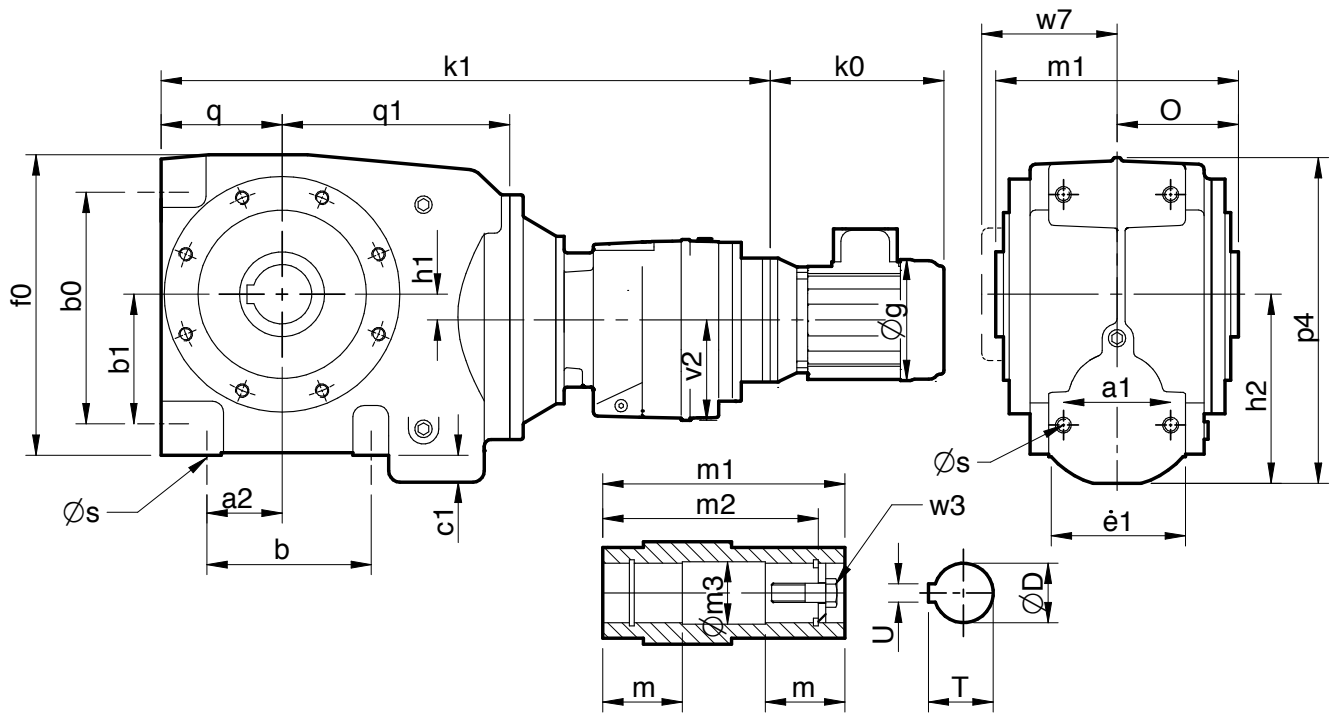

Size	a1	a2	b	b0	b1	c1	e1	f0	h1	h2	o	p4	q	q1
S0341	54	35	63	80	40	9	70	139	5.3	79.5	62	148	54	109
S0441	56	35	80	118	65	7	80	158	15	93	65	168	64	119
S0541	68	45	100	142	77	16	86	177	13	112	70	200	68	134
S0641	80	56	122	172	96	20	102	218	17	139.5	90	243	90	169

Size	s	v2	w7	D	m	m1	m2	m3	T	U	w3
S0341	M8 x 1.25 x 15	76	70	20	52	124	104	20.2	22.9	6	M6 x 1.0 x 40
S0441	M10 x 1.5 x 20	76	74.5	30	54	130	122	30.2	33.5	8	M10 x 1.5 x 50
S0541	M10 x 1.5 x 18	76	79	35	56	140	127	35.3	38.5	10	M12 x 1.75 x 55
S0641	M12 x 1.75 x 20	91	101	45	70	180	156	45.3	49	14	M16 x 2.0 x 70

Size	S0341 S0441 S0541 S0641					
	k0	g	k1	k1	k1	k1
63	195	125	383	403	422	495
71	220	140	387	407	426	499
80	240	160	400	420	439	512
90S	260	180	410	430	449	522
90L	280	180	410	430	449	522
100L	310	200	418	438	457	530
112M	330	225	418	438	457	530

S SERIES DIMENSIONS QUADRUPLE REDUCTION

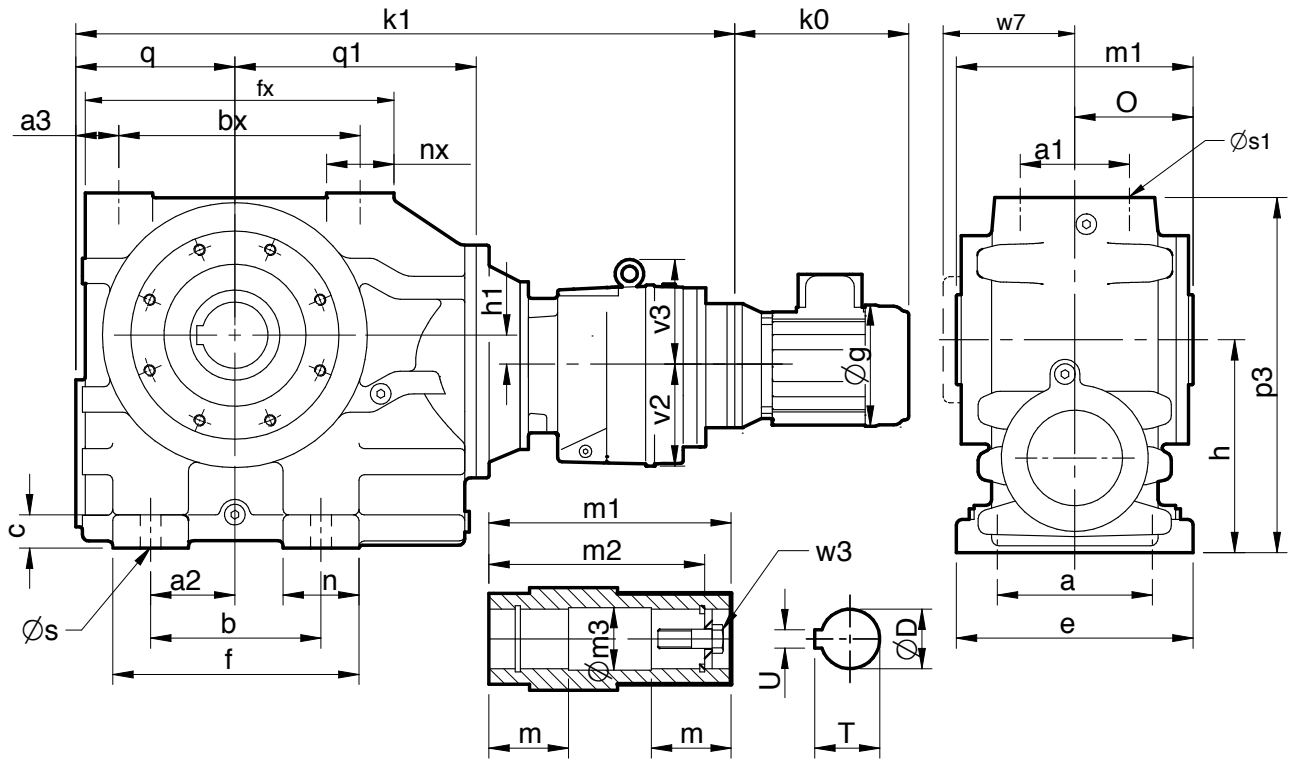

Size	a	a1	a2	a3	b	bx	c	e	f	fx	h	h1	n	nx	o	p3	q	q1
S0741	150	100	75	35.5	135	215	28	185	202	280	180	26	67	63	109	302	143	220
S0841	200	120	92	43	180	250	35	250	260	326	225	28	80	71	125	375	168	255
S0941	250	135	115	50	235	290	40	305	320	380	280	40	85	85	150	457	195	300
S1041	300	150	170	62.5	310	345	45	360	420	460	335	65	110	107	175	565	235	355

Size	s	s1	v2	v3	w7	D	m	m1	m2	m3	T	U	w3
S0741	18	M20 x 2.5 x 34	91	-	125	60	79	218	188	60.5	64.6	18	M20 x 2.5 x 80
S0841	22	M20 x 2.5 x 34	115	-	143	70	90	250	220	70.5	75.1	20	M20 x 2.5 x 80
S0941	26	M24 x 3.0 x 45	115	-	169	90	107.5	300	265	90.5	95.6	25	M24 x 3.0 x 110
S1041	26	M24 x 3.0 x 45	140	155	198	100	132.5	350	313	100.5	106.6	28	M24 x 3.0 x 110

Size	S0741		S0841	S0941	S1041
	k0	g	k1	k1	k1
63	195	125	600	680	763
71	220	140	604	686	769
80	240	160	617	704	787
90S	260	180	627	714	797
90L	280	180	627	714	797
100L	310	200	635	741	824
112M	330	225	635	741	824
132S	380	260	-	741	824
132M	420	260	-	741	824
160M	480	320	-	-	971
160L	530	320	-	-	971

S SERIES

DIMENSIONS

UNITS WITH COMPACT MOTOR

Double Reduction Units

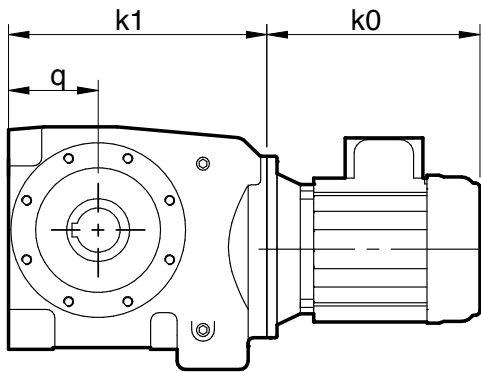

S0321 - S0621

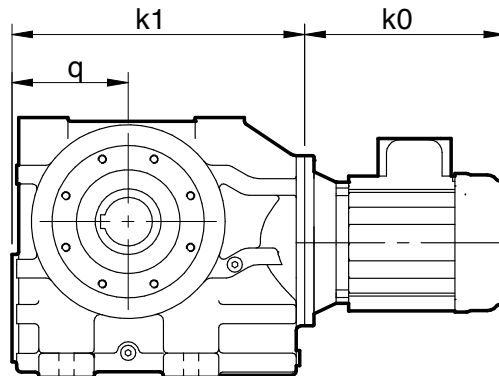

S0721 - S0821

Size	S0321				S0421			S0521			S0621			S0721			S0821			
	g	k1	k0	q	k1	k0	q	k1	k0	q	k1	k0	q	k1	k0	q	k1	k0	q	
0.25 kW	140	163	230	54	183	230	64	202	230	68	-	-	-	-	-	-	-	-	-	-
0.37 kW	140	163	230	54	183	230	64	202	230	68	-	-	-	-	-	-	-	-	-	-
0.55 kW	158	163	280	54	183	280	64	202	280	68	259	265	90	-	-	-	-	-	-	-
0.75 kW	158	163	300	54	183	300	64	202	300	68	259	285	90	-	-	-	-	-	-	-
1.1 kW	180	163	330	54	183	330	64	202	330	68	259	315	90	363	300	143	-	-	-	-
1.5 kW	180	163	365	54	183	365	64	202	365	68	259	350	90	363	335	143	-	-	-	-
2.2 kW	198	-	-	-	-	-	-	-	-	-	259	355	90	363	340	143	423	335	168	-
3.0 kW	198	-	-	-	-	-	-	-	-	-	259	365	90	363	350	143	423	350	168	-
4.0 kW	222	-	-	-	-	-	-	-	-	-	259	424	90	363	410	143	423	400	168	-
5.5 kW	262	-	-	-	-	-	-	-	-	-	259	495	90	363	480	143	423	475	168	-
7.5 kW	262	-	-	-	-	-	-	-	-	-	-	-	-	363	480	143	423	475	168	-

Triple Reduction Units

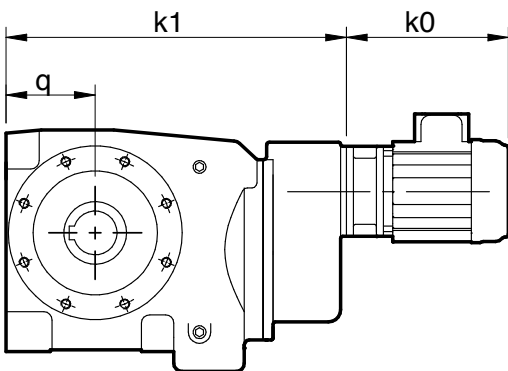

S0331 - S0631

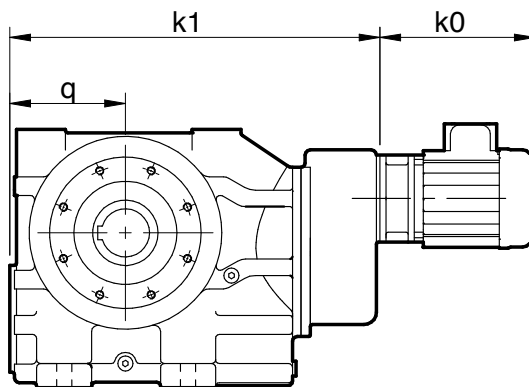

S0731 - S0831

Size	S0331				S0431			S0531			S0631			S0731		
	g	k1	k0	q	k1	k0	q	k1	k0	q	k1	k0	q	k1	k0	q
0.25 kW	140	219	230	54	239	230	64	258	230	68	325	230	90	-	-	-
0.37 kW	140	219	230	54	239	230	64	258	230	68	325	230	90	-	-	-
0.55 kW	160	219	280	54	239	280	64	258	280	68	325	280	90	449	265	143
0.75 kW	160	219	300	54	239	300	64	258	300	68	325	300	90	449	285	143
1.1 kW	180	210	330	54	239	330	64	258	330	68	325	330	90	449	315	143
1.5 kW	180	219	365	54	239	365	64	258	365	68	325	365	90	449	350	143
2.2 kW	200	-	-	-	-	-	-	-	-	-	-	-	-	449	355	143
3.0 kW	200	-	-	-	-	-	-	-	-	-	-	-	-	449	365	143
4.0 kW	225	-	-	-	-	-	-	-	-	-	-	-	-	449	424	143
5.5 kW	260	-	-	-	-	-	-	-	-	-	-	-	-	449	495	143

S SERIES DIMENSIONS UNITS WITH COMPACT MOTOR

Quadruple Reduction Units

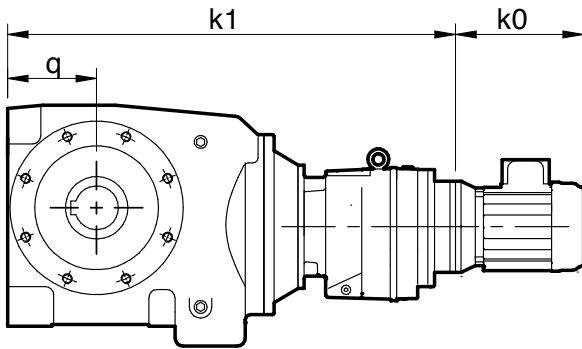

S0341 - S0641

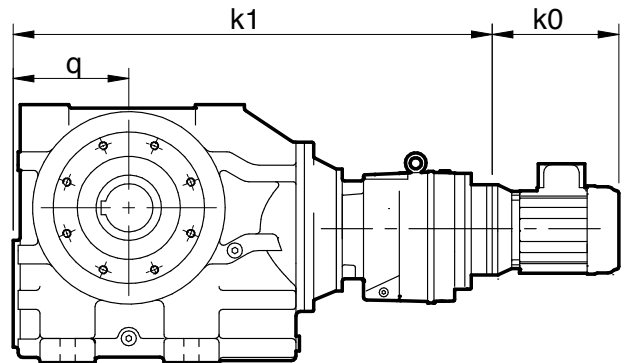

S0741 - S0841

Size	S0341				S0441			S0541			S0641			S0741		
	g	k1	k0	q	k1	k0	q	k1	k0	q	k1	k0	q	k1	k0	q
0.25 kW	140	349	230	54	369	230	64	388	230	68	461	230	90	566	230	143
0.37 kW	140	349	230	54	369	230	64	388	230	68	461	230	90	566	230	143
0.55 kW	160	349	280	54	369	280	64	388	280	68	461	280	90	566	280	143
0.75 kW	160	349	300	54	369	300	64	388	300	68	461	300	90	566	300	143

Size	S0841				S0941			S1041		
	g	k1	k0	q	k1	k0	q	k1	k0	q
0.55 kW	160	668	265	168	751	265	195	-	-	-
0.75 kW	160	668	285	168	751	285	195	-	-	-
1.1 kW	180	668	315	168	751	315	195	882	300	235
1.5 kW	180	668	350	168	751	350	195	882	335	235
2.2 kW	200	668	355	168	751	355	195	882	340	235
3.0 kW	200	668	365	168	751	365	195	882	350	235
4.0 kW	225	668	424	168	751	424	195	882	410	235
5.5 kW	260	668	495	168	751	495	195	882	480	235
7.5 kW	-	-	-	-	-	-	-	882	480	235

S SERIES

GEAR UNIT OPTIONS

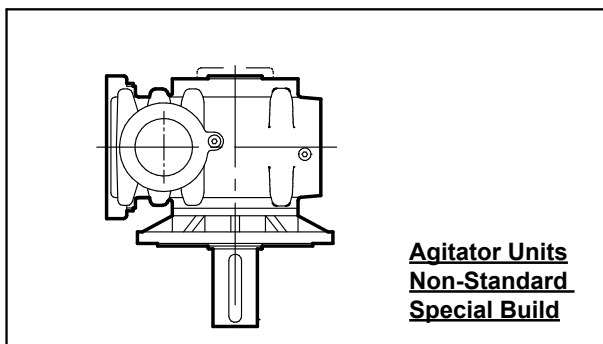
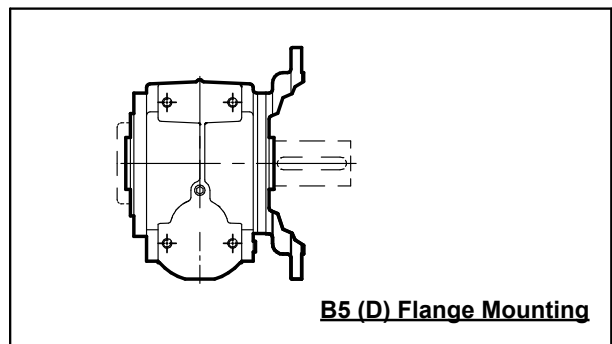
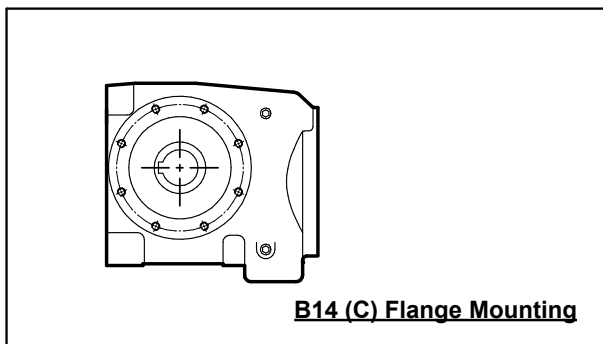
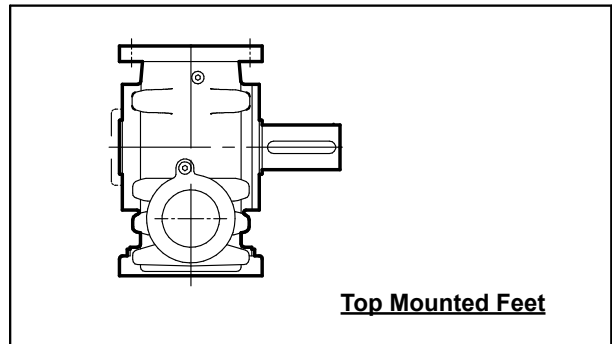
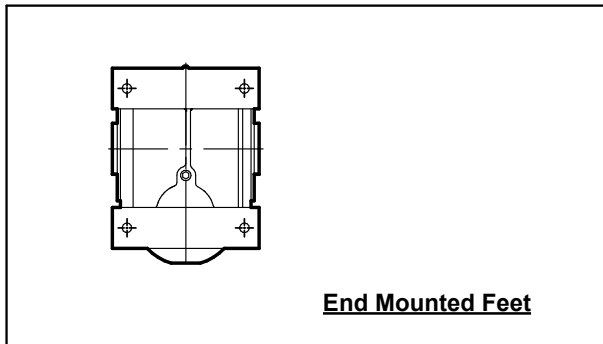
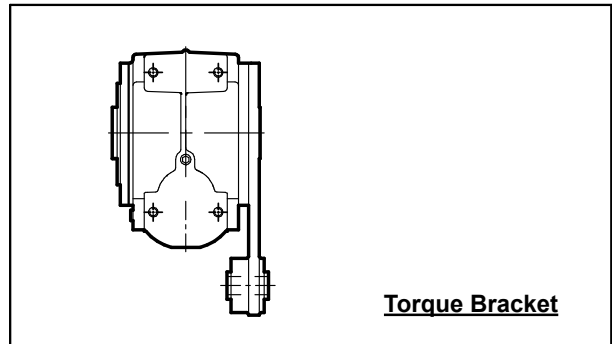
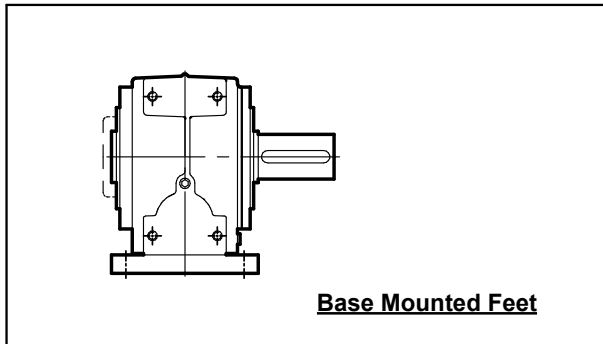
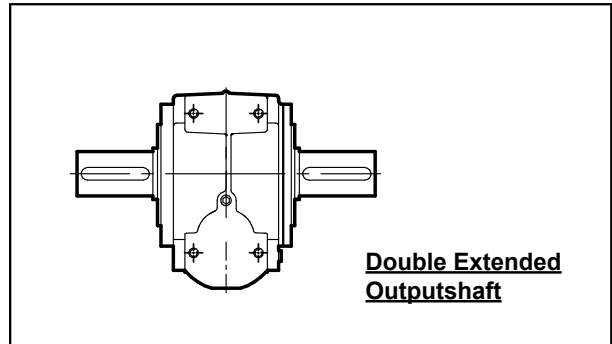
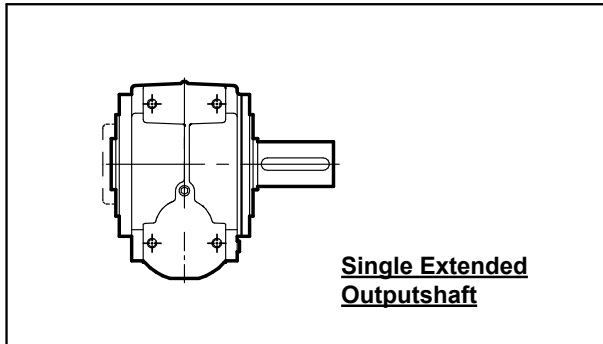

S SERIES

MOTORISED BACKSTOP MODULE

Motorised backstop modules can be fitted between the gear unit and motor. The backstop device incorporates high quality centrifugal lift off sprags which are wear free above the lift off speed (n min). To ensure correct operation motor speed must exceed lift off speed.

Suitable for ambient temperature -40°C to + 50°C

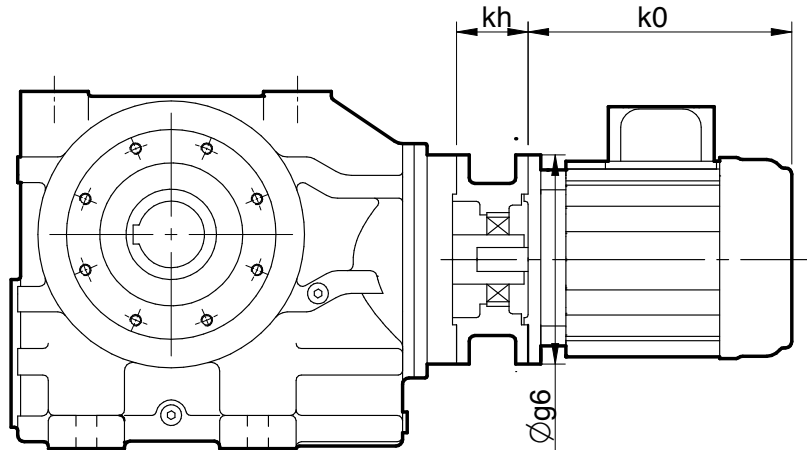

Warning

Removal of motor or backstop will release the drive. Ensure all driven machinery is secure prior to any maintenance work

IEC B5 FLANGE

Motor Frame Size	Lift off Speed ('n' min) (rev/min)	Rated Locking Torque ('T max') (at motor) (Nm)	øg6	kh
100	670	170	250	70
112	670	170	250	70
132	620	940	300	95
160	620	940	350	130
180	620	940	350	130
200	550	1260	400	130

NEMA C FLANGE

Motor Frame Size	Lift off Speed ('n' min) (rev/min)	Rated Locking Torque ('T max') (at motor) (Nm)	øg6	kh
182TC / 184TC	670	300	228	95.25
213TC / 215TC	670	300	228	95.25
254TC / 256TC	620	940	228	120.65
284TC / 286TC	620	940	280	136.50
324TC / 326TC	550	1260	330	152.40

When a backstop module is fitted dimension kh should be added to the overall length of the geared motor assembly.

Rotation of outputshaft must be specified when ordering as viewed from the outputshaft end (as shown in the diagram)

- | | | | | |
|--------|-------|-------------------|-------|-------------------|
| CW | - | Free Rotation | - | Clockwise |
| | | Locked | | Anticlockwise |
|
AC |
- |
Free Rotation |
- |
Anticlockwise |
| | | Locked | | Clockwise |

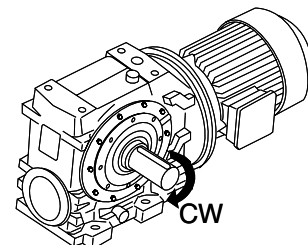

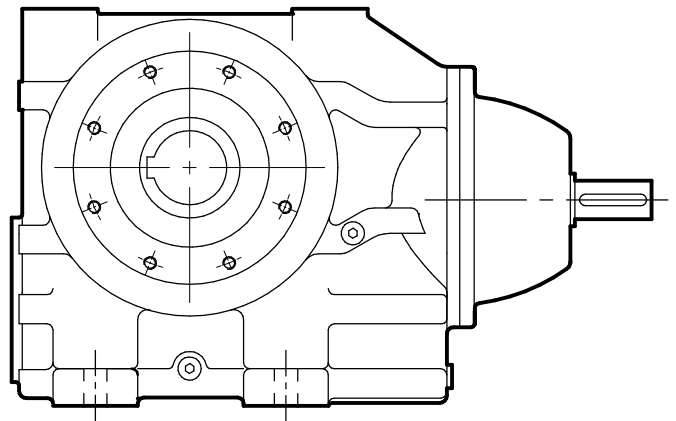
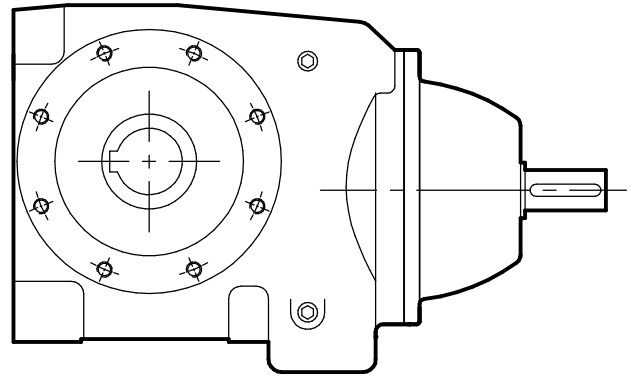

REDUCER

S SERIES

S SERIES OVERHUNG & AXIAL LOADS (NEWTONS) ON SHAFTS

Maximum permissible overhung loads

When a sprocket, gear etc. is mounted on the shaft a calculation, as below, must be made to determine the overhung load on the shaft, and the results compared to the maximum permissible overhung loads tabulated. Overhung loads can be reduced by increasing the diameter of the sprocket, gear, etc. If the maximum permissible overhung load is exceeded, the sprocket, gear, etc. should be mounted on a separate shaft, flexibly coupled and supported in its own bearings, or the gear unit shaft should be extended to run in an outboard bearing. Alternatively, a larger gear is often a less expensive solution.

Permissible overhung loads vary according to the direction of rotation. The values tabulated are for the most unfavourable direction with the unit transmitting full rated power and the load P applied midway along the shaft extension. Hence they can sometimes be increased for a more favourable direction of rotation, or if the power transmitted is less than the rated capacity of the gear unit, or if the load is applied nearer to the gear unit case. Refer to our Application Engineers for further details. In any event, the sprocket, gear etc. should be positioned as close as possible to the gear unit case in order to reduce bearing loads and shaft stresses, and to prolong life. All units will accept 100% momentary overload on stated capacities.

Overhung load (Newtons)

$$P = \frac{kW \times 9,500,000 \times K}{N \times R}$$

where

- P = equivalent overhung load (Newtons)
 kW = power transmitted by the shaft (kilowatts)
 N = speed of shaft (rpm)
 R = pitch radius of sprocket, etc. (mm)
 K = factor

1 Newton = 0.10197kG (0.2248 lbs)

Overhung load

K (factor)

Chain sprocket*	1.00
Spur or helical pinion	1.25
Vee belt sheave	1.50
Flat belt pulley	2.00

* If multistrand chain drives are equally loaded and the outer strand is further than dimension A output or B input, refer to our Application Engineers.

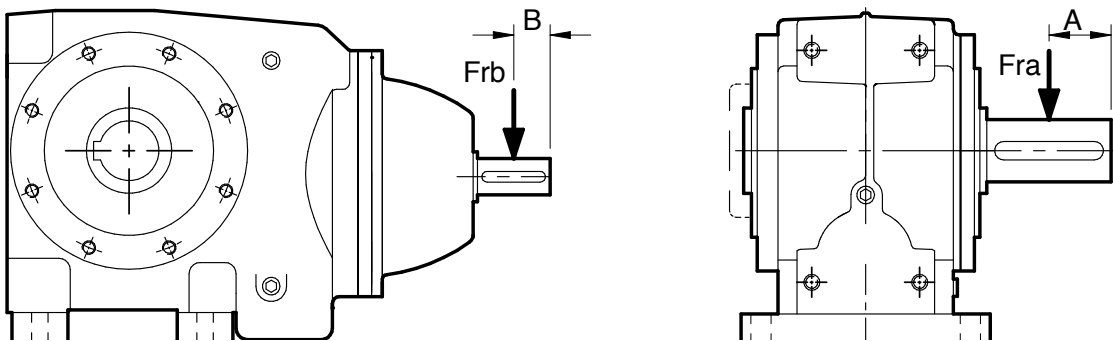

Distance midway along the shaft extension

Size of unit	No. of Reductions	Dimension A (mm)	Dimension B (mm)
S03	2 - 3	17.5	20
S04	2 - 3	23	20
S05	2 - 3	30	20
S06	2 - 5	31.5	20
S07	2	38	25
S07	3 - 5	38	20
S08	2	60	30
S08	4 - 5	60	20
S09	2	67.5	40
S09	4 - 5	67.5	20
S10	2	85	55
S10	4	85	25
S10	5	85	20

Inputshaft Overhung Loads. Frb (Kn) 1450 rpm - Two Three and Four Stage Units

	S03	S04	S05	S06	S07	S08	S09	S10
2 Stage	1.50	1.50	1.25	1.05	2.1	3.1	3.5	4.5
4 Stage	1.50	1.50	1.50	1.50	1.50	1.50	1.50	1.80

For output overhung load Fra consult ratings tables.

Axial Thrust Capacities (Newtons) No check or calculation is required for axial loads (FA) towards or away from the unit up to 50% of the permissible overhung load. If the axial thrust considerably exceeds these values or if there is a combination of axial thrust loads and overhung loads please contact our Application Engineers.

S SERIES

DIMENSIONS

DOUBLE REDUCTION

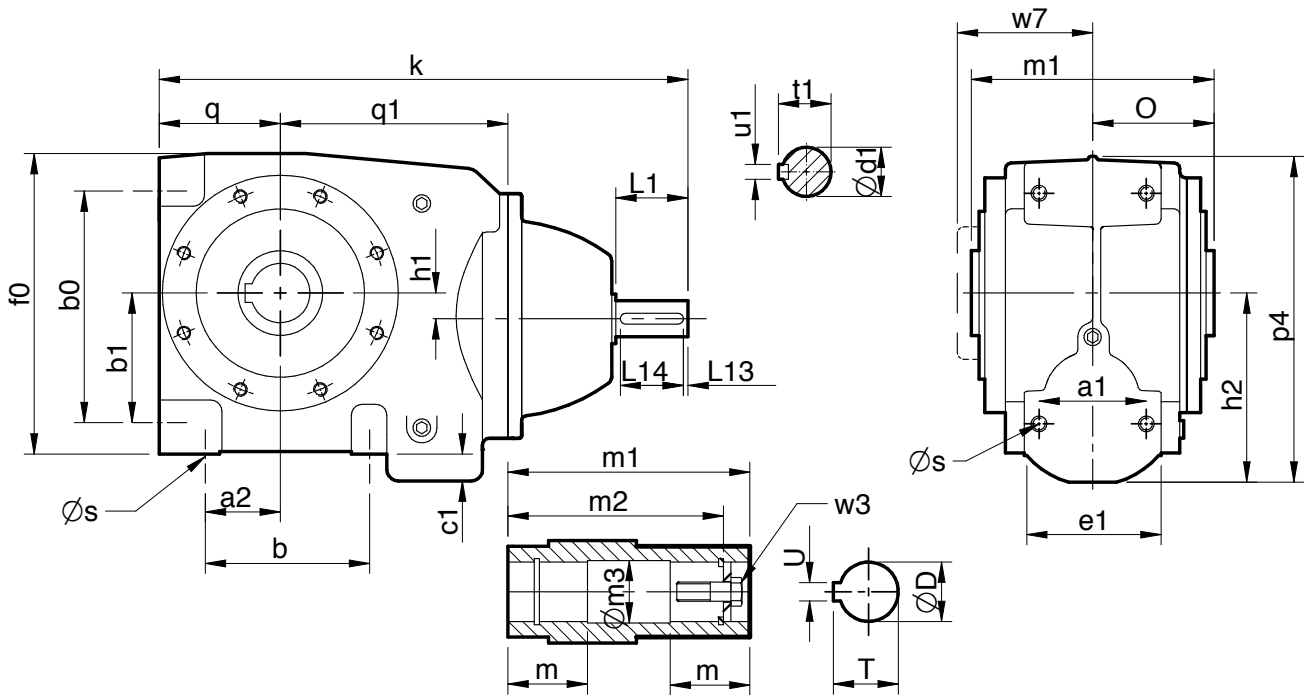

Size	a1	a2	b	b0	b1	c1	e1	f0	h1	h2	o
S0321	54	35	63	80	40	9	70	139	5.3	79.5	62
S0421	56	35	80	118	65	7	80	158	15	93	65
S0521	68	45	100	142	77	16	86	177	13	112	70
S0621	80	56	122	172	96	20	102	218	17	139.5	90

Size	p4	q	q1	s	w7	k
S0321	148	54	109	M8 x1.25 x 15	70	274
S0421	168	64	119	M10 x1.5 x 20	74.5	294
S0521	200	68	134	M10 x1.5 x 18	79	313
S0621	243	90	169	M12 x1.75 x 20	101	370

Size	d1	L1	L13	L14	t1	u1	D	m	m1	m2	m3	T	U	w3
S0321	16 k6	40	4	32	18	5	20	52	124	104	20.2	22.9	6	M6x1.0 x 40
S0421	16 k6	40	4	32	18	5	30	54	130	122	30.2	33.5	8	M10x1.5 x 50
S0521	16 k6	40	4	32	18	5	35	56	140	127	35.3	38.5	10	M12x1.75 x 55
S0621	19 k6	40	4	32	21.5	6	45	70	180	156	45.3	49	14	M16x2.0 x 70

S SERIES

DIMENSIONS

DOUBLE REDUCTION

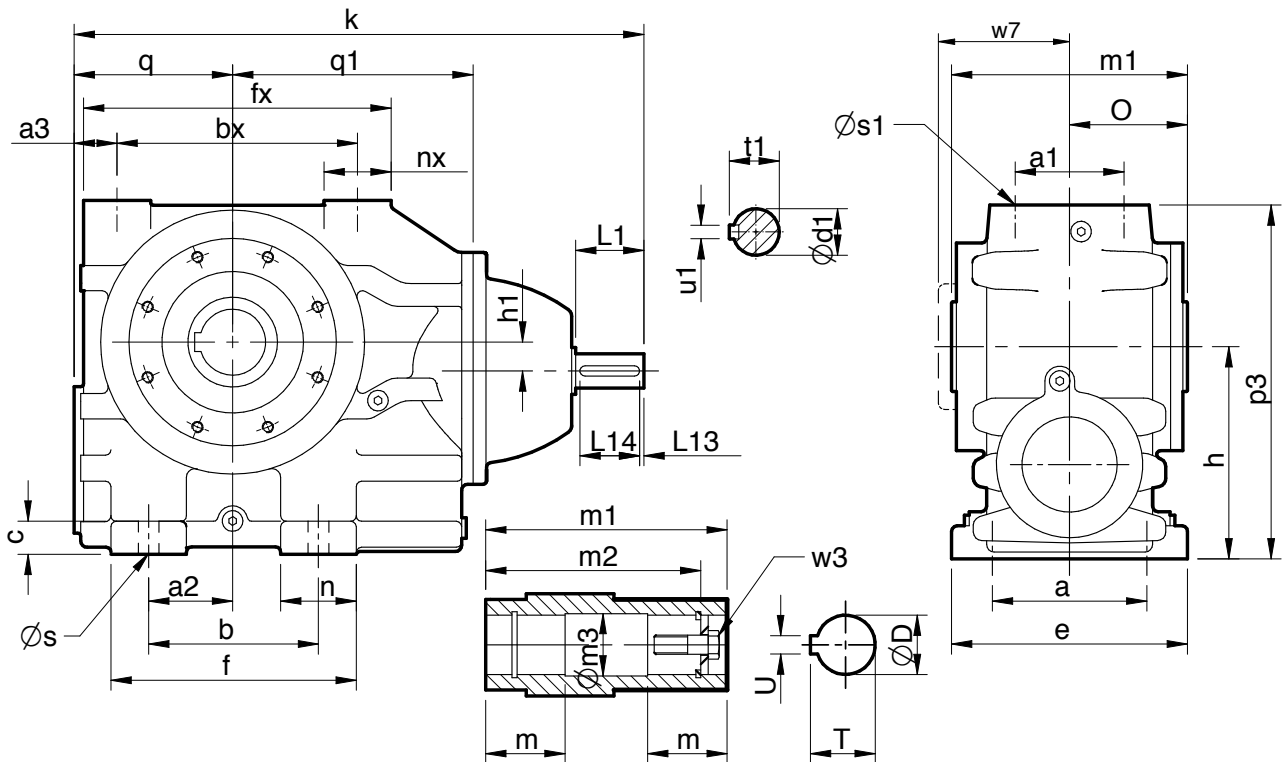

Size	a	a1	a	a3	b2	bx	c	e	f	fx	h	h1	n	nx	o
S0721	150	100	75	35,5	135	215	28	185	202	280	180	26	67	63	109
S0821	200	120	92	43	180	250	35	250	260	326	225	28	80	71	125
S0921	250	135	115	50	235	290	40	305	320	380	280	40	85	85	150
S1021	300	150	170	62,5	310	345	45	360	420	460	335	65	110	107	175

Size	p4	q	q1	s	s1	w7	k
S0721	302	143	220	18	M20 x 2,5 x 34	125	478
S0821	375	168	255	22	M20 x 2,5 x 34	143	583
S0921	457	195	300	26	M24 x 3,0 x 45	169	690
S1021	565	235	355	26	M24 x 3,0 x 45	198	823

Size	d1	L1	L13	L14	t1	u1	D	m	m1	m2	m3	T	U	w3
S0721	24 k6	50	5	40	27	8	60	79	218	188	60,5	64,6	18	M20 x 2,5 x 80
S0821	28 k6	60	5	50	31	8	70	90	250	220	70,5	75,1	20	M20 x 2,5 x 80
S0921	38 k6	80	5	70	41	10	90	107,5	300	265	90,5	95,6	25	M24 x 3,0 x 110
S1021	42 k6	110	10	70	45	12	100	132,5	350	313	100,5	106,6	28	M24 x 3,0 x 110

S SERIES

DIMENSIONS

TRIPLE REDUCTION

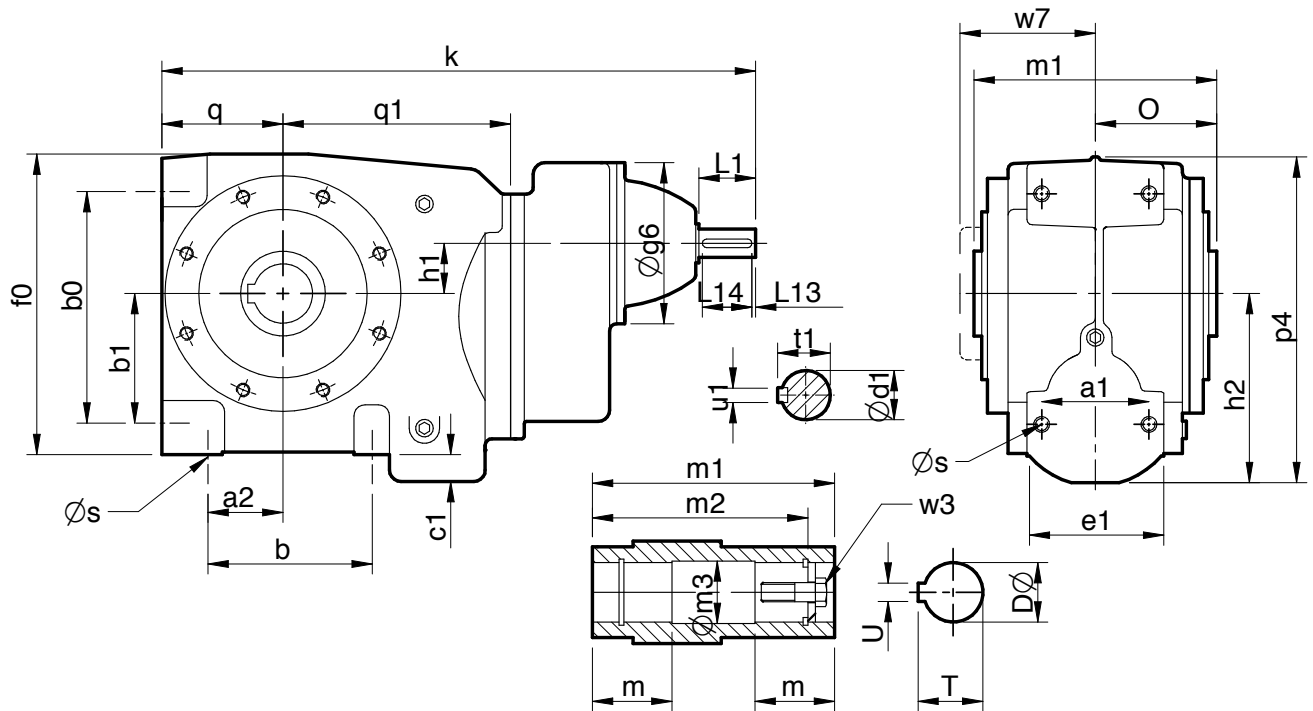

Size	a1	a2	b	b0	b1	c1	e1	f0	h1	h2	k	o
S0331	54	35	63	80	40	9	70	139	30.75	79.5	330	62
S0431	56	35	80	118	65	7	80	158	21.2	93	350	65
S0531	68	46	100	14	277	16	86	177	23	11	369	70
S0631	80	56	122	172	96	20	102	218	30	139.5	436	90

Size	p4	q	q1	s	w7
S0331	148	54	109	M8 x 1.25 x 15	70
S0431	168	64	119	M10 x 1.5 x 18	74.5
S0531	200	68	134	M10 x 1.5 x 18	79
S0631	243	90	169	M12 x 1.75 x 20	101

Size	d1	L1	L13	L14	t1	u1	D	m	m1	m2	m3	T	U	w3
S0321	16 k6	40	4	32	18	5	20	52	124	104	20.2	22.9	6	M6 x 1.0 x 40
S0421	16 k6	40	4	32	18	5	30	54	130	122	30.2	33.5	8	M10 x 1.5 x 50
S0521	16 k6	40	4	32	18	5	35	56	140	127	35.3	38.5	10	M12 x 1.75 x 55
S0621	19 k6	40	4	32	21.5	6	45	70	180	156	45.3	49	14	M16 x 2.0 x 70

S SERIES

DIMENSIONS

TRIPLE REDUCTION

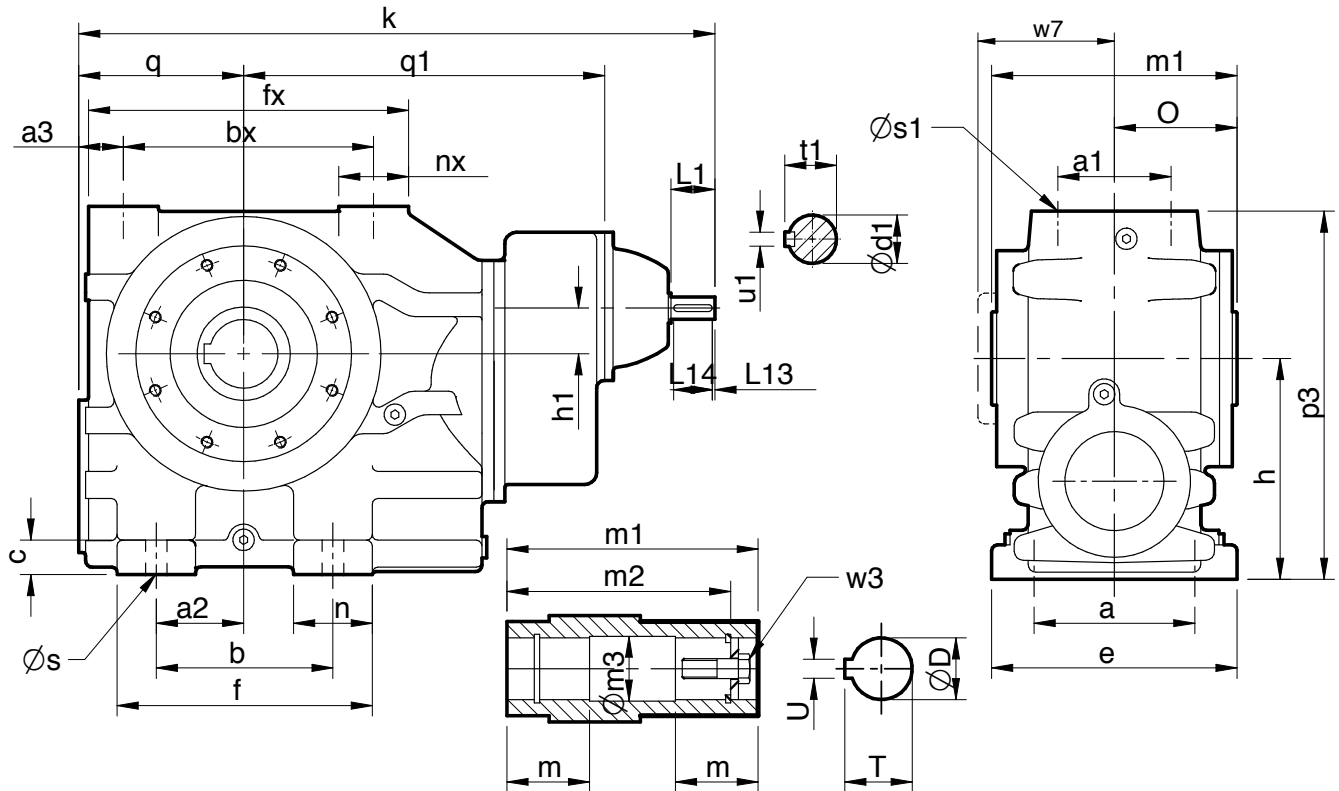

Size	a	a1	a2	a3	b	bx	c	e	f	fx	h	h1	k	n	nx	o	p3	q	q1
S0731	150	100	75	35.5	135	215	28	185	202	280	180	34	560	67	63	109	302	143	220

Size	p3	q	q1	s	s1	w7	g6
S0731	302	143	220	18	M20 x 2.5 x34	125	212

Size	d1	L1	L13	L14	t	u1	D	m	m1	m2	m3	T	U	w3
S0731	24 k6	50	5	40	27	8	60	79	218	188	60.5	64.6	18	M20 x 2.5 x 80

S SERIES

DIMENSIONS

QUADRUPLE REDUCTION

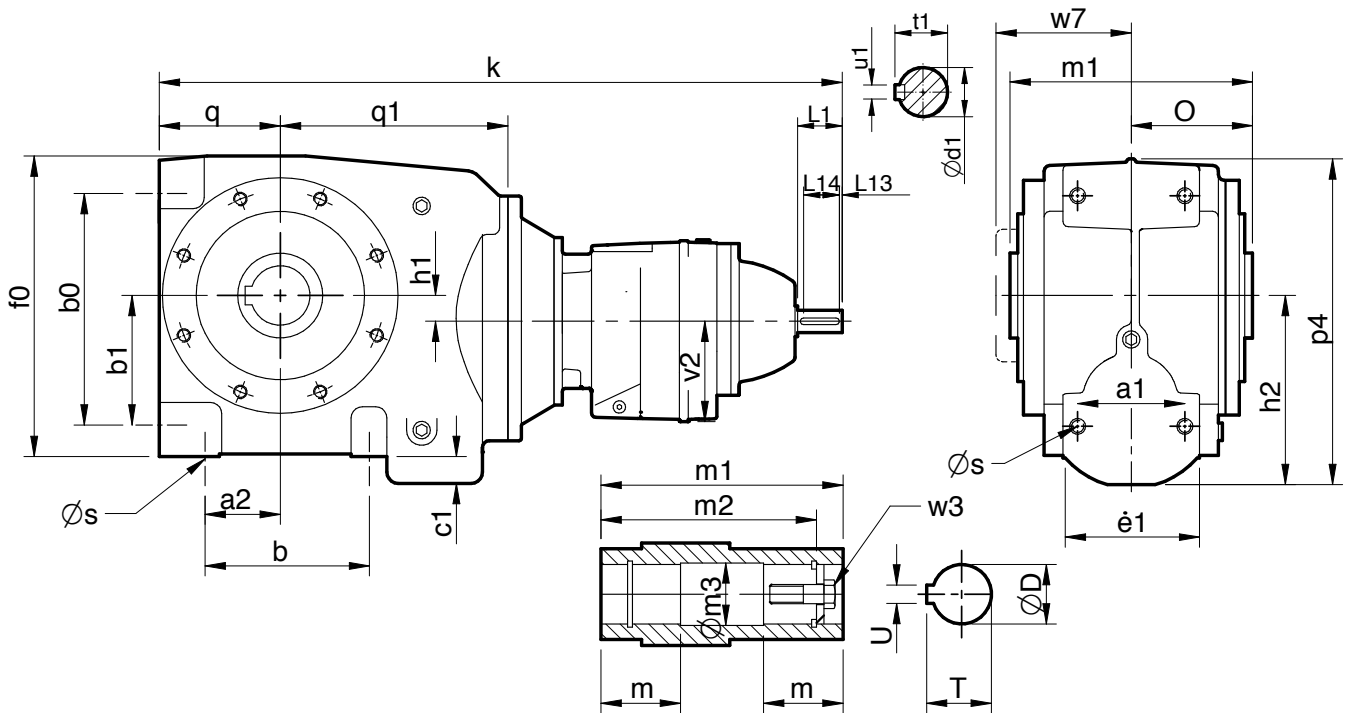

Size	a1	a2	b	b0	b1	c1	e1	f0	h1	h2	o
S0341	54	35	63	80	40	9	70	139	5.3	79.5	62
S0441	56	35	80	118	65	7	80	158	15	93	65
S0541	68	45	100	142	77	16	86	177	13	112	70
S0641	80	56	122	172	96	20	102	218	17	139.5	90

Size	p4	q	q1	s	v2	w7	k
S0341	148	54	109	M8 x1.25 x 15	76	70	460
S0441	168	64	119	M10 x1.5 x 20	76	74.5	480
S0541	200	68	134	M10 x1.5 x 18	76	79	499
S0641	243	90	169	M12 x1.75 x 20	91	101	572

Size	d1	L1	L13	L14	t1	u1	D	m	m1	m2	m3	T	U	w3
S0341	16 k6	40	4	32	18	5	20	52	124	104	20.2	22.9	6	M6 x1.0 x 40
S0441	16 k6	40	4	32	18	5	30	54	130	122	30.2	33.5	8	M10 x1.5 x 50
S0541	16 k6	40	4	32	18	5	35	56	140	127	35.3	38.5	10	M12 x1.75 x 55
S0641	16 k6	40	4	32	18	5	45	70	180	156	45.3	49	14	M16 x2.0 x 70

S SERIES

DIMENSIONS

QUADRUPLE REDUCTION

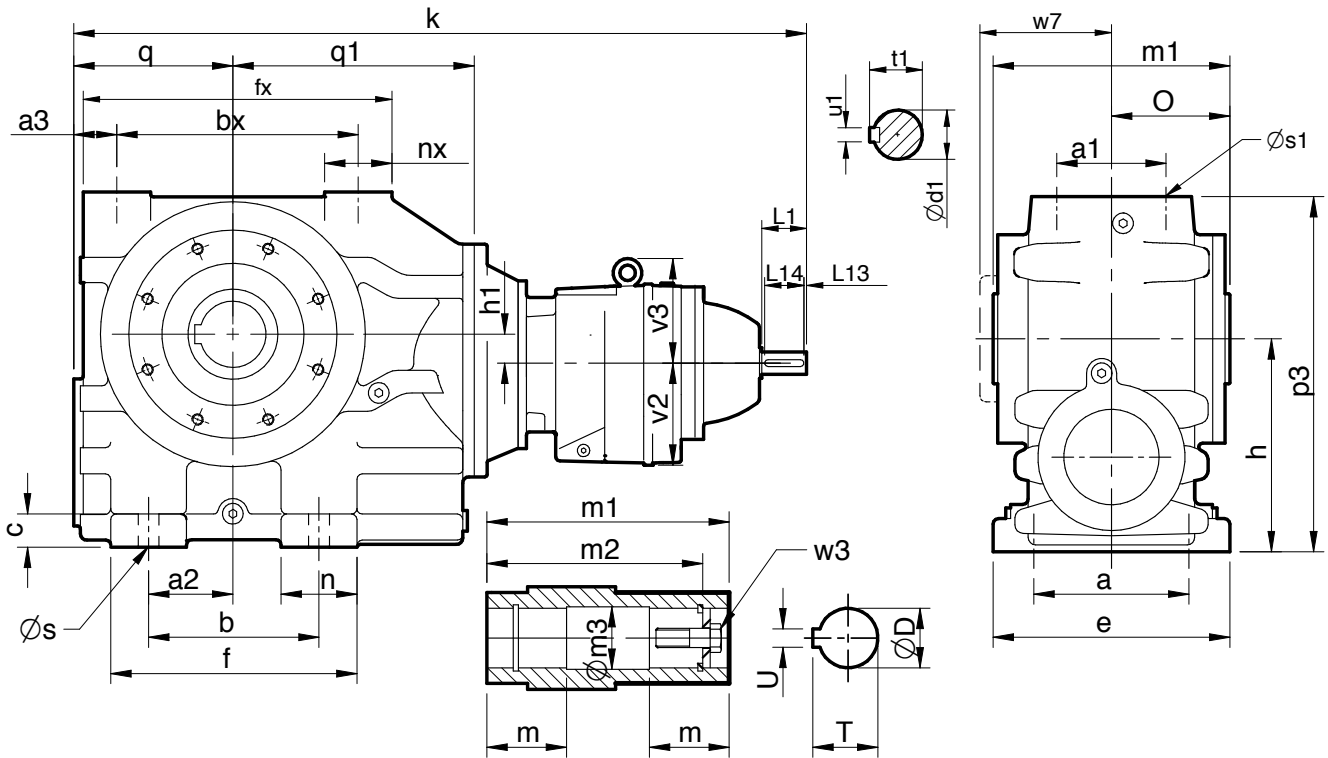

Size	a	a1	a2	a3	b	bx	c	e	f	fx	h	h1	n	nx	o
S0741	150	100	75	35.5	135	215	28	185	202	280	180	26	67	63	109
S0841	200	120	92	43	180	250	35	250	260	326	225	28	80	71	125
S0941	250	135	115	50	235	290	40	305	320	380	280	40	85	85	150
S1041	300	150	170	62.5	310	345	45	360	420	460	335	65	110	107	175

Size	p3	q	q1	s	s1	v2	v3	w7	k
S0741	302	143	220	18	M20 x 2.5 x 34	91	-	125	677
S0841	375	168	255	22	M20 x 2.5 x 34	115	-	143	779
S0941	457	195	300	26	M24 x 3.0 x 45	115	-	169	862
S1041	565	235	355	26	M24 x 3.0 x 45	140	155	198	997

Size	d1	L1	L13	L14	t1	u1	D	m	m1	m2	m3	T	U	w3
S0741	16 k6	40	4	32	18	5	60	79	218	188	60.5	64.6	18	M20 x 2.5 x 80
S0841	19 k6	40	4	32	21.5	6	70	90	250	220	70.5	75.1	20	M20 x 2.5 x 80
S0941	19 k6	40	4	32	21.5	6	90	107.5	300	265	90.5	95.6	25	M24 x 3.0 x 110
S1041	24 k6	50	5	40	27	8	100	132.5	350	313	100.5	106.6	28	M24 x 3.0 x 110

S SERIES

DIMENSIONS - FEET

S 0 2 B R

STANDARD UNIT WITH BASE MOUNTED FEET

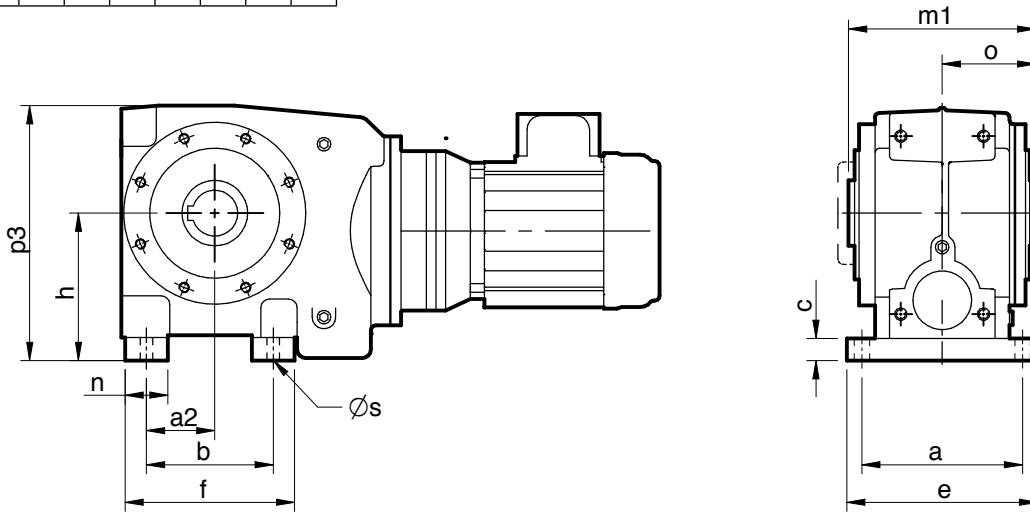

S 0 2 E R

STANDARD UNIT WITH END MOUNTED FEET

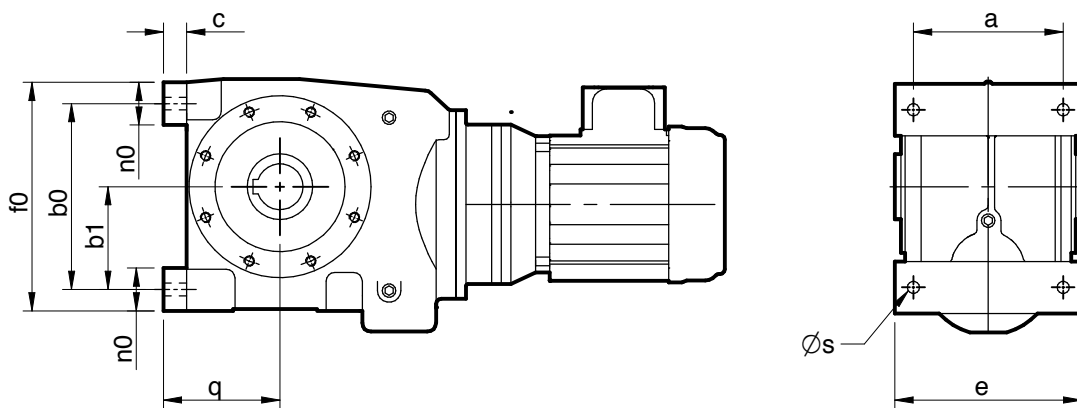

Size	a	b	b0	b1	c	e	f	f0	h	n	n0	p3	q	q2	s
S03	90	63	80	40	9	110	88	105	80	25	25	148	63	35	9
S04	100	80	118	65	14	124	115	153	100	35	35	175	78	35	11
S05	110	100	142	77	16	136	140	182	112	40	40	200	84	45	11
S06	130	130	180	100	20	160	172	222	140	50	50	243	110	60	14

S SERIES

DIMENSIONS - FEET

S

--	--	--	--	--	--	--	--	--	--	--	--

E R STANDARD UNIT WITH END MOUNTED FEET

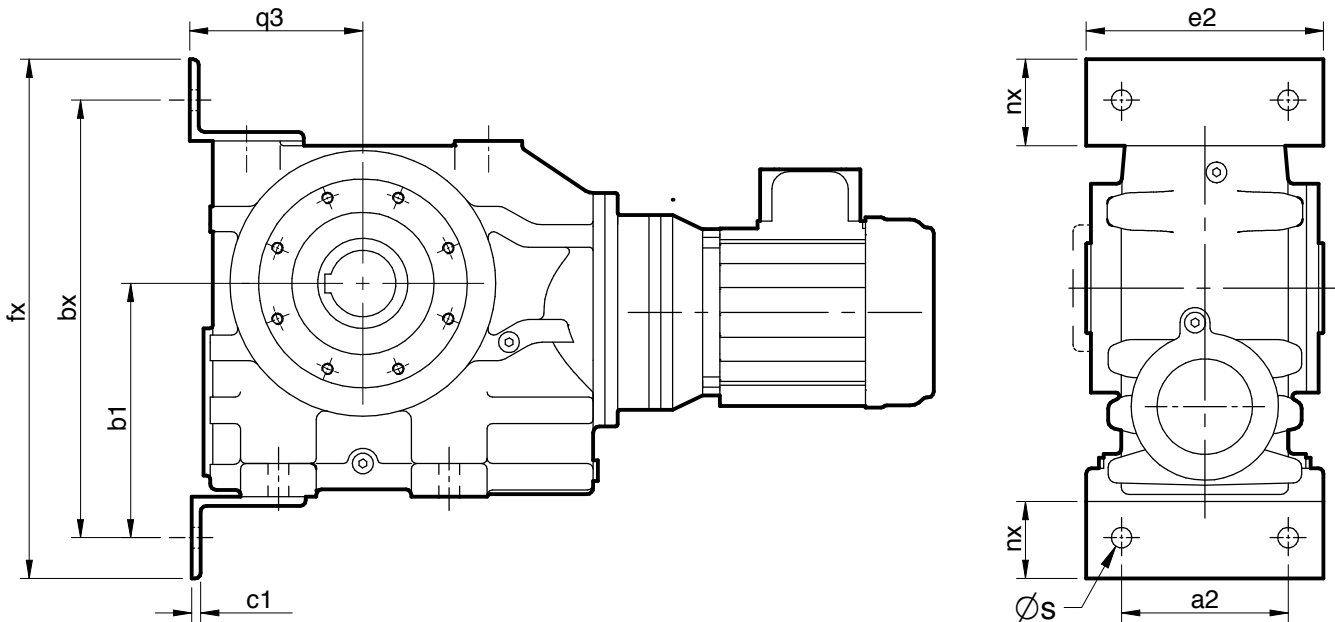

Size	a2	bx	b1	c1	e2	fx	nx	q3	s
S07	170	392	225	12	220	452	75	162	22
S08	200	465	270	12	250	525	75	187	22
S09	250	557	330	15	305	637	90	220	26
S10	300	665	385	15	360	745	90	260	26

S

--	--	--	--	--	--	--	--	--	--	--	--

R R STANDARD UNIT WITH TOP MOUNTED FEET

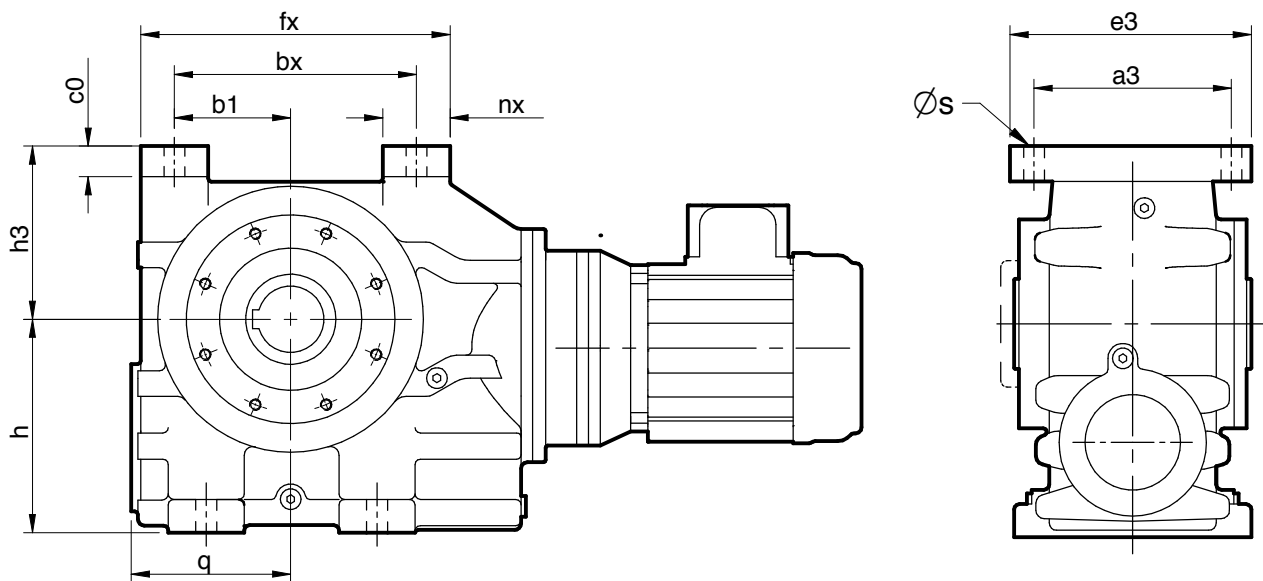

Size	a3	b1	bx	co	e3	fx	h	h3	nx	q	s
S07	205	107.5	215	28	256	278	180	150	63	143	24
S08	225	125	250	30	280	320	225	180	70	168	24
S09	240	145	290	35	300	370	280	212	80	195	28
S10	265	172.5	345	35	330	445	335	265	100	235	28

S SERIES

THERMAL POWER RATING

Thermal Ratings kW

Thermal ratings are a measure of the units ability to dissipate heat, if they are exceeded the lubricant may break down resulting in premature gear failure.

The ratings listed below are true for horizontal mounting position 1 running continuously with an ambient temperature equal to 20°C. For other mounting positions, ambients and units operating intermittently multiply thermal power ratings by factors Ft, Fp and Fd as appropriate.

Table 1 Thermal Power (kW)

Overall ratios	Input rpm	S03	S04	S05	S06	S07	S08	S09	S10
8 - 14	2900	2.80	3.85	4.69	5.1	Consult our Application engineers			
	1750	1.98	3.26	4.85	5.27				
	1450	1.73	2.85	4.41	4.46	5.71	9.53	18.2	32.5
	1160	1.45	2.40	3.89	3.91	5.71	9.53	11.5	27.7
	960	1.24	2.10	3.45	3.50	5.71	9.53	11.2	24.6
	725	1.07	1.69	2.70	2.79	5.31	9.02	10.0	20.6
	480	0.74	1.22	1.93	1.99	4.11	7.12	9.85	14.6
16 - 28	2900	1.70	2.76	3.07	3.73	Consult our Application engineers			
	1750	1.28	2.03	3.48	3.53				
	1450	1.09	1.62	3.18	3.20	4.95	7.41	12.9	19.4
	1160	0.92	1.37	2.78	2.80	4.81	7.27	11.8	17.0
	960	0.83	1.26	2.45	2.49	4.48	6.91	10.7	14.9
	725	0.67	0.96	1.97	2.02	3.96	6.91	8.71	12.4
	480	0.47	0.66	1.64	1.66	2.90	4.87	6.50	8.78
> 28	2900	1.22	2.15	3.20	4.41	7.26	9.64	18.6	36.1
	1750	0.84	1.44	2.35	3.70	5.44	7.35	13.0	23.3
	1450	0.69	1.15	2.05	3.26	4.88	7.32	11.6	20.1
	1160	0.57	0.95	1.72	2.79	4.44	7.06	10.9	16.6
	960	0.51	0.85	1.55	2.43	3.97	6.47	8.76	14.1
	725	0.40	0.66	1.18	1.78	3.53	5.15	7.25	11.0
	480	0.33	0.45	0.87	1.28	2.50	3.70	5.37	7.53
	250	0.18	0.30	0.54	0.70	1.33	2.25	2.97	4.07

Table 2. Thermal service factor Ft

Thermal service factor for ambient temperature

Ambient temperature	-30	-20	-10	0	10	20	30	40	50
Factor	1.68	1.55	1.41	1.27	1.14	1.0	0.84	0.68	0.50

Table 3. Thermal service factor Fp

Thermal service factor for mounting positions

Unit Output Speed (Rev/min)			Mounting Position				
			1	2 & 3	4	5	6
0	to	25	1.00	0.997	0.996	0.995	0.993
>25	to	50	1.00	0.993	0.990	0.986	0.982
>50	to	75	1.00	0.987	0.981	0.974	0.968
>75	to	100	1.00	0.980	0.970	0.960	0.950
>100	to	200	1.00	0.943	0.914	0.886	0.858
>200	to	300	1.00	0.896	0.844	0.792	0.840
>300	to	400	1.00	0.840	0.760	0.680	0.600
>400			1.00	0.809	0.724	0.618	0.533

Table 4. Thermal service factor Fd

Thermal service factor for duration of running

Unit Output Speed (Rev/min)			% Running time per hour				
			100	80	60	40	20
0	to	10	1.00	1.18	1.45	1.72	2.38
>10	to	25	1.00	1.16	1.39	1.64	2.22
>25	to	50	1.00	1.14	1.31	1.54	2.00
>50	to	100	1.00	1.08	1.19	1.33	1.64
>100	to	150	1.00	1.04	1.08	1.19	1.41
>150	to	200	1.00	1.00	1.00	1.06	1.23
>200			1.00	1.00	1.00	1.00	1.00

S SERIES

FAN COOLED UNITS

Table 5. Thermal Power (kW) With Cooling Fan

Overall ratios	Input RPM	S03	S04	S05	S06	S07	S08	S09	S10
8 - 14	2900	-	-	-	-	Consult our Application engineers			
	1750	-	-	-	-				
	1450	-	-	-	-	11,4	19,1	36,4	65,0
	1160	-	-	-	-	10,6	17,6	22,5	52,2
	960	-	-	-	-	10,0	16,7	19,6	43,0
	725	-	-	-	-	8,00	13,5	15,0	30,9
>14	2900	-	-	-	-	Consult our Application engineers			
	1750	-	-	-	-				
	1450	-	-	-	-	11,2	17,5	30,6	50,6
	1160	-	-	-	-	9,90	14,8	25,8	38,8
	960	-	-	-	-	8,90	13,4	21,8	31,5
	725	-	-	-	-	7,84	12,1	18,7	26,1

Note: When checking thermal capacities use actual load required to be transmitted, not rating of prime mover.

Column 10 Entry

For reducer fan kit modules enter S in column 10
or if used in conjunction with a reducer backstop module kit

Y CW rotation
Z CCW rotation

Dimensions of Fan Cooled Units

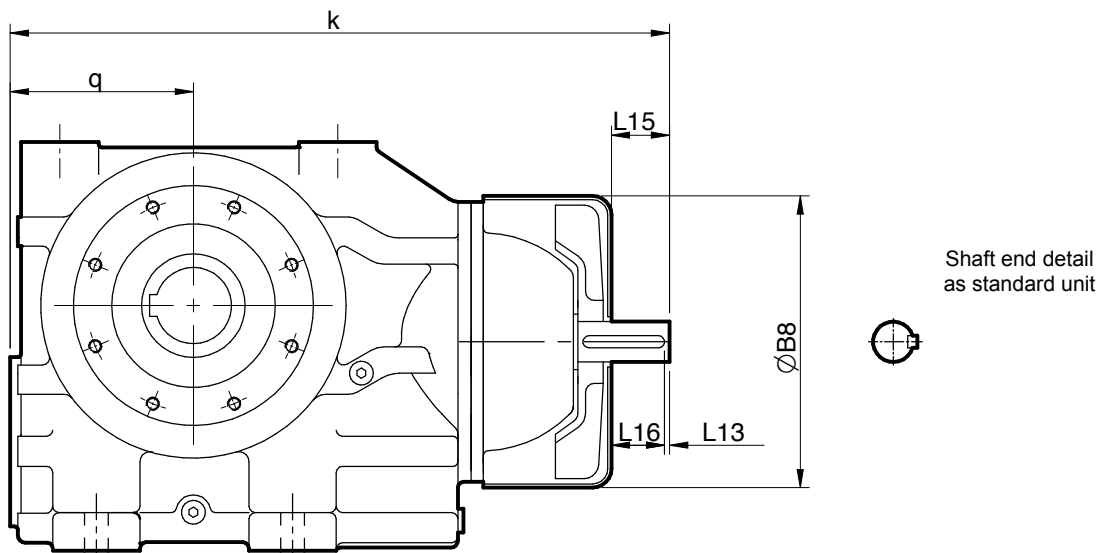

Size	$\varnothing B8$	k	L13	L15	L16	q
S0721	225	478	5	35	30	143
S0821	265	583	5	45	40	168
S0921	320	690	5	65	60	195
S1021	380	823	10	95	85	235

S SERIES

REDUCER BACKSTOP MODULE

The reducer units listed below can be fitted with an internal backstop, this has no effect of the external unit size. The backstop device incorporates high quality centrifugal lift off sprags which are wear free above the lift off speed (n min). To ensure correct operation input speed must exceed lift off speed.

Suitable for ambient temperature -40°C to + 50°C

Column 10 Entry

For reducer fan kit modules enter W for CCW rotation (or Z if used in conjunction with a fan kit)
X for CW rotation (or Y if used in conjunction with a fan kit)

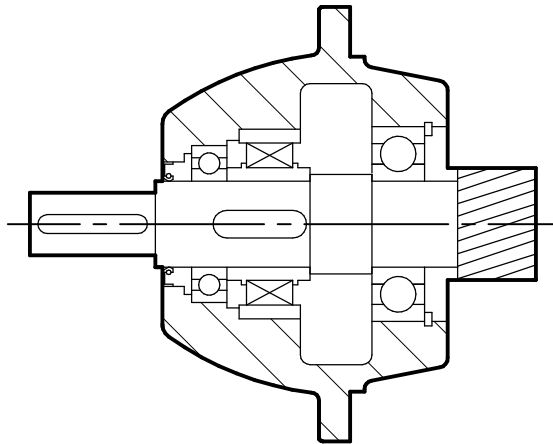

Size	Lift off speed ('n min) at inputshaft (rev/min)	Rated locking Torque ('T max') at inputshaft (Nm)
S0622/S0842/S0941	800	100
S0722/S1041	670	170
S0822	670	300
S0921	620	940
S1021	550	1260

Rotation of outputshaft must be specified when ordering as viewed from the outputshaft end (as shown in the diagram)

- | | | | | |
|----|---|---------------|---|---------------|
| CW | - | Free Rotation | - | Clockwise |
| | | Locked | | Anticlockwise |
| AC | - | Free Rotation | - | Anticlockwise |
| | | Locked | - | Clockwise |

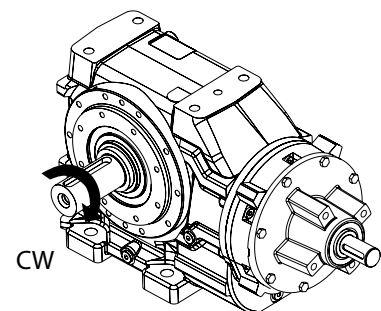

S SERIES

DIMENSIONS

OUTPUTSHAFT OPTIONS

STANDARD OUTPUTSHAFT OPTION

S03 - S06

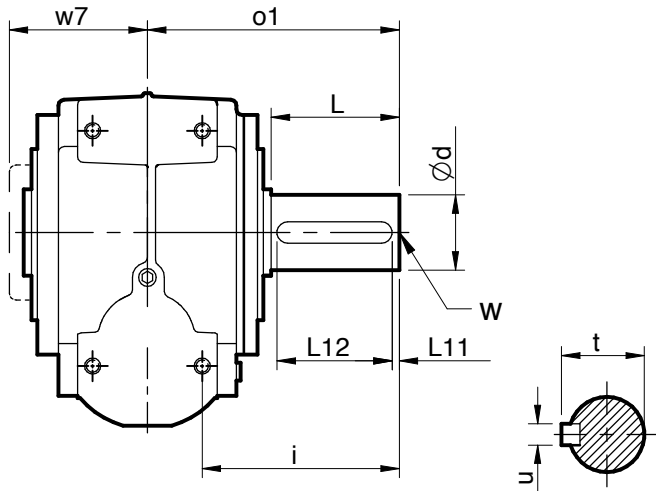

STANDARD DOUBLE EXTENDED OUTPUTSHAFT OPTION

S03 - S06

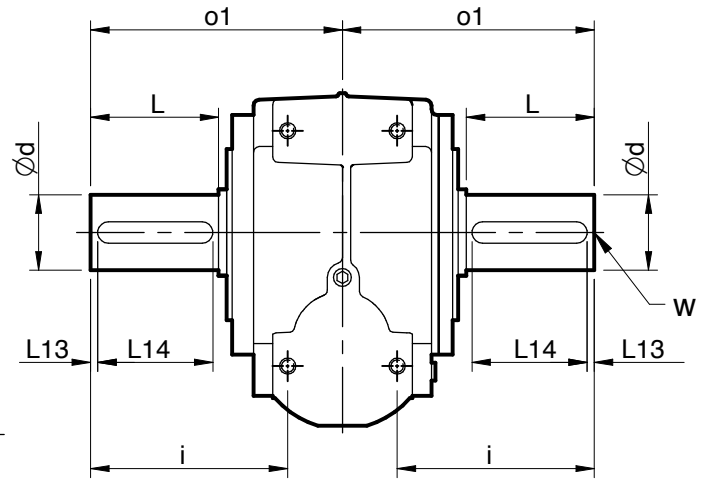

S07 - S10

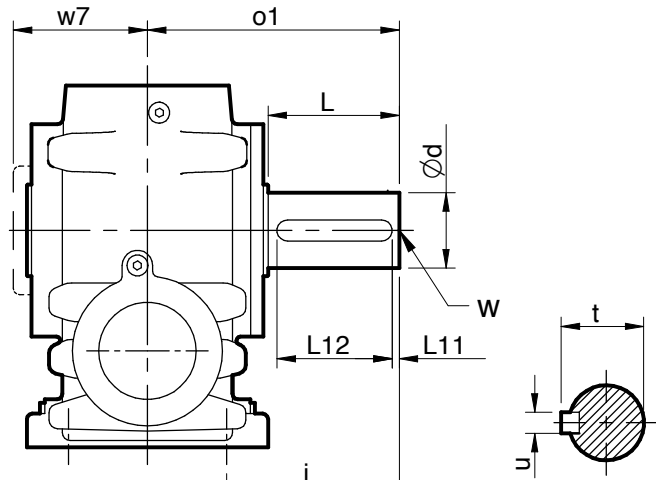

S07 - S10

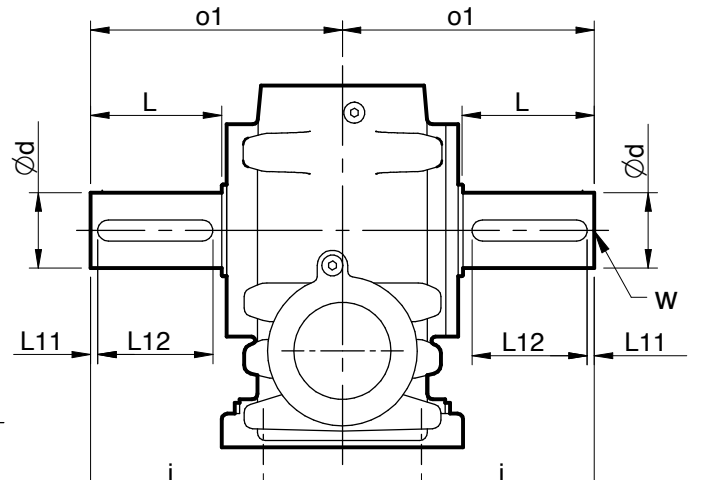

Size	ød	i	L	L11	L12	o1	t	u	w	w7
S0321	20,015 / 20,002	73	35	3	31	100	22,5	6	M8 x 1.0 x 16	70
S0421	25,015 / 25,002	87	46	3	42	115	28	8	M10 x 1.5 x 22	74,8
S0521	30,015 / 30,002	100	60	3	53	134	33	8	M10 x 1.5 x 22	79
S0621	35,018 / 35,002	120	63	3	55	160	38	10	M12 x 1.75 x 25	101
S0621 Heavy duty	45,018 / 45,002	155	98	5	80	195	48,5	14	M12 x 1.75 x 25	101
S0721	45,018 / 45,002	120	76	3	70	195	48,5	14	M16 x 2.0 x 36	125
S0821	60,030 / 60,011	155	120	3	110	255	64	18	M20 x 2.5 x 42	143
S0921	70,030 / 70,011	170	135	3	125	295	74,5	20	M20 x 2.5 x 42	169
S1021	90,035 / 90,013	216	170	3	160	366	95	25	M24 x 3.0 x 50	198

S SERIES TORQUE ARM

It is recommended that the torque arm is positioned such that the it is fitted on the side of the unit adjacent to the driven machine.

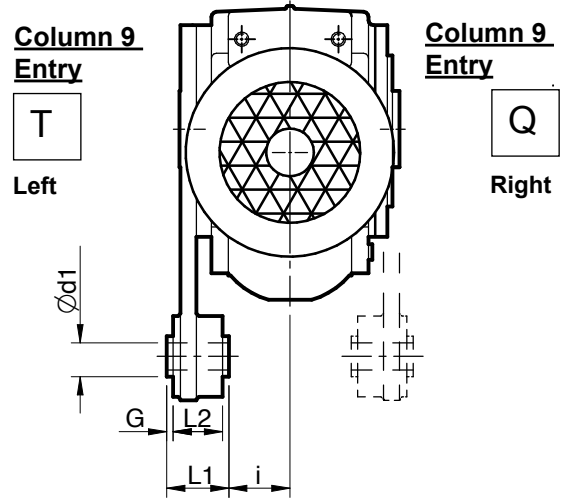
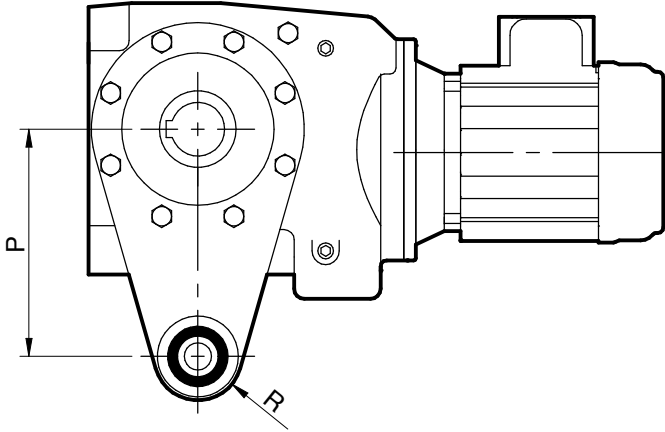

Size	d1	G	i	L1	L2	P	R
S03	10.3	2	47	36	32	110	23
S04	10.3	2	52	36	32	130	23
S05	10.3	2	52	36	32	160	23
S06	16.3	2	71.5	44	32	200	38

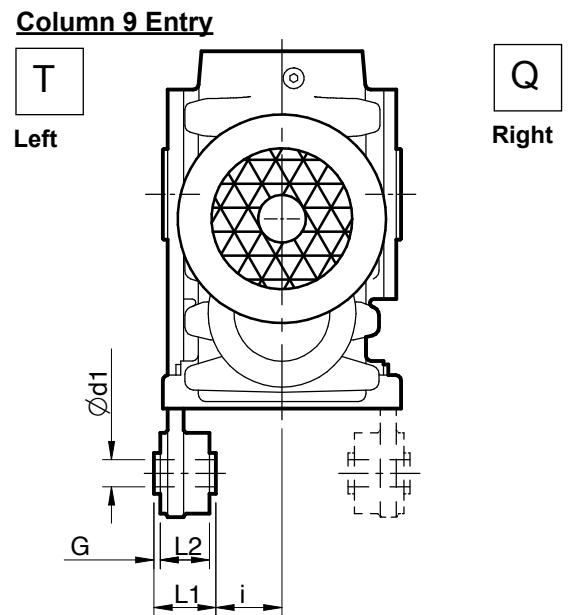
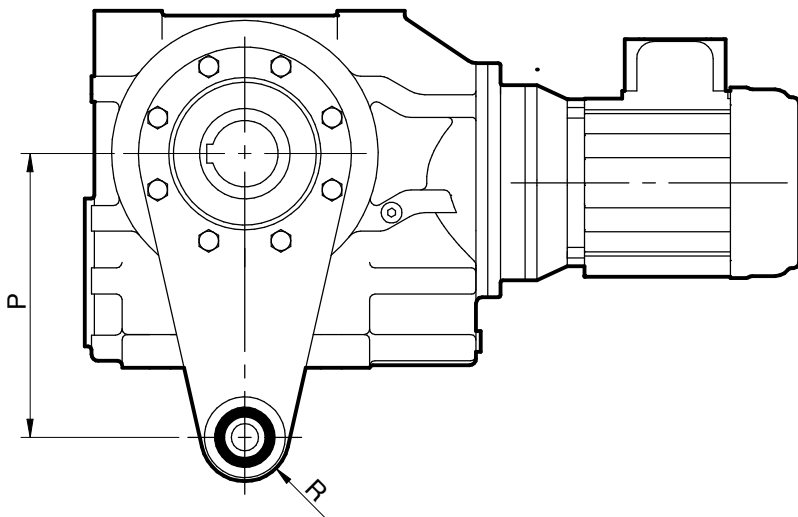

Size	$\varnothing d1$	G	i	L1	L2	P	R
S07	16.3	2	77.5	60	56	250	38
S08	16.3	2	85.5	60	56	310	38
S09	25	5	98	80	70	380	45
S10	25	5	137	80	70	430	45

S SERIES

DIMENSIONS

D (B5) FLANGE

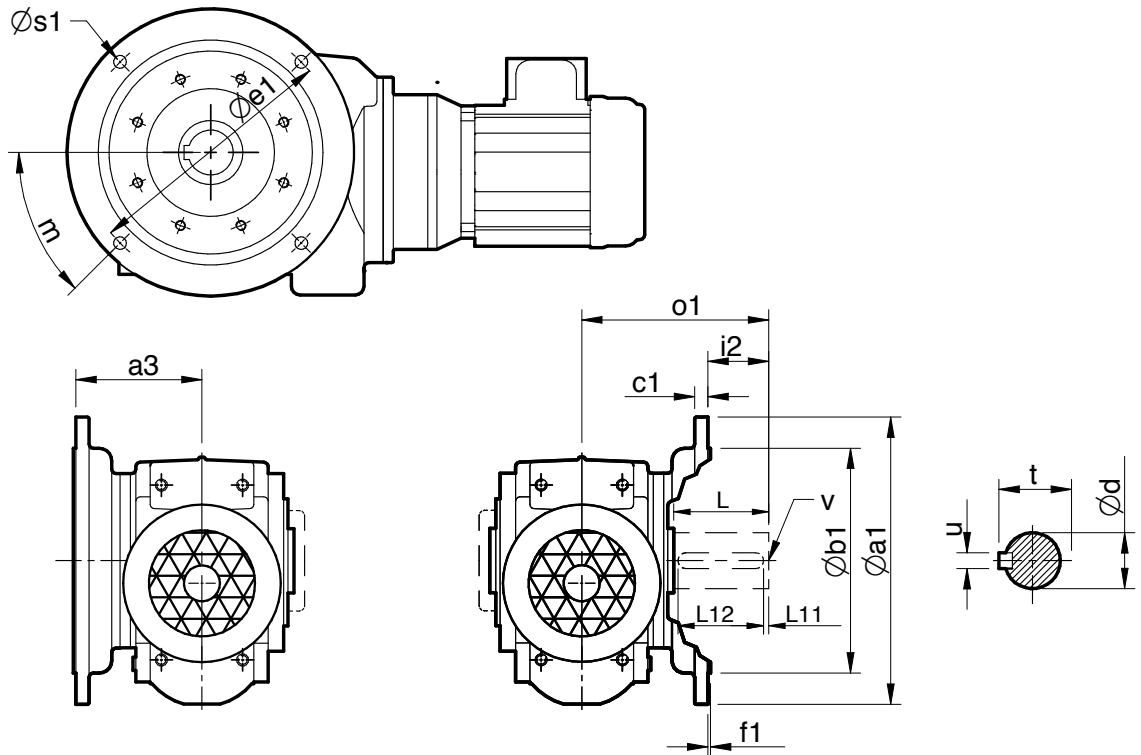

Column 9 Entry

F Left

Column 9 Entry

H Right

Size	Øa1	a3	Øb1	c1	Øe1	f1	m	Øs1
S03 Red Dia.	120	75	80 j6	8	100	3	45°	6.6
S03	160	75	110 j6	10	130	4	45°	9
S04	160	86	110 j6	10	130	3.5	45°	9
S05	200	107	130 j6	12	165	3.5	45°	11
S06	200	120	130 j6	12	165	3.5	45°	11
S07	250	145	180 j6	12	215	4	45°	14
S08	350	170	250 h6	18	300	5	45°	18
S09	450	200	350 h6	20	400	5	22.5°	18
S10	450	232	350 h6	22	400	5	22.5°	18

Size	Ød	i 2	L	L11	L12	o1	t	u	v
S0321	20.015 / 20.002	25	35	3	31	100	22.5	6	M8 x 1.0 x 16
S0421	25.015 / 25.002	40	46	3	42	115	28	8	M10 x 1.5 x 22
S0521	30.015 / 30.002	48	60	3	53	134	33	8	M10 x 1.5 x 22
S0621	35.018 / 35.002	53	63	3	55	160	38	10	M12 x 1.75 x 22
S0621 Heavy duty	45.018 / 45.002	75	98	5	80	195	48.5	14	M12 x 1.75 x 22
S0721	45.018 / 45.002	50	76	3	70	195	48.5	14	M16 x 2.0 x 36
S0821	60.030 / 60.011	85	120	3	110	255	64	18	M20 x 2.5 x 42
S0921	70.030 / 70.011	95	135	3	125	295	74.5	20	M20 x 2.5 x 42
S1021	90.035 / 90.013	134	170	3	160	366	95	25	M24 x 3.0 x 50

S SERIES DIMENSIONS C (B14) FLANGE

S04, S05, S06, S08

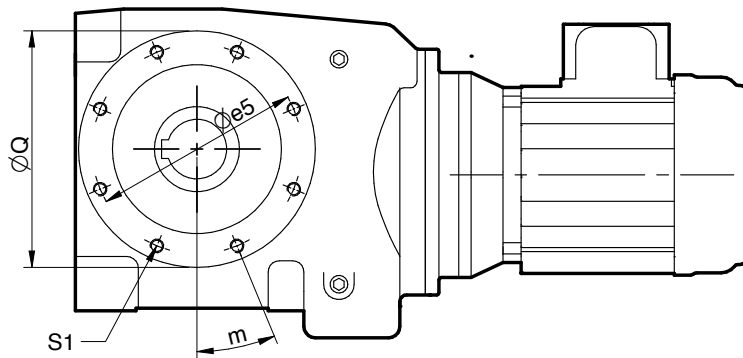

S03

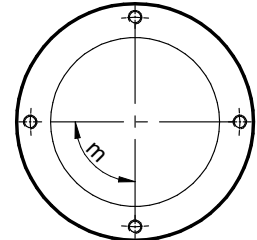

S07, S09

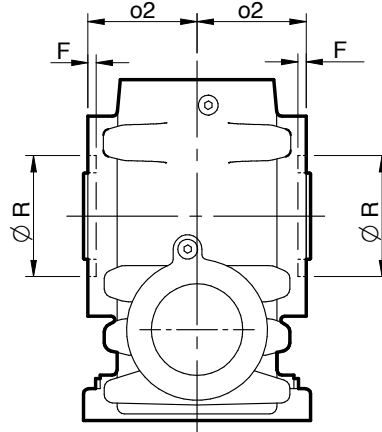
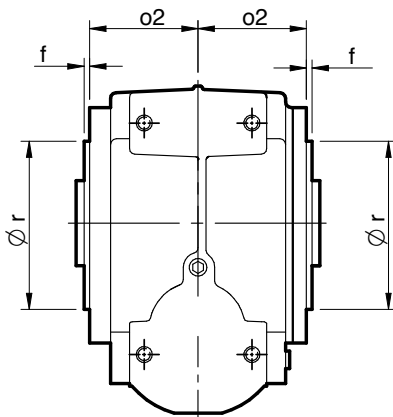
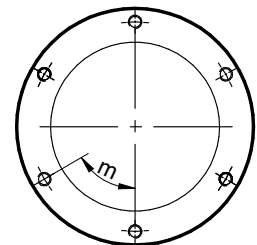

S10

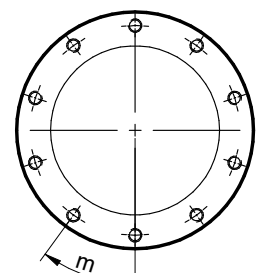

S03 - S06

Male spigot

S07 - S10

Female recess

Size	øe5	f	F	m	o2	ø Q	ø r (h7)	ø R (H7)	S1
S03	90	4	-	90°	57	106	70	-	(4) M8 x 1.25 x 22
S04	107	4	-	22.5°	57	122	85	-	(8) M8 x 1.25 x 22
S05	130	4	-	22.5°	62	146	105	-	(8) M8 x 1.25 x 22
S06	155	5	-	22.5°	81	175	125	-	(8) M10 x 1.5 x 22
S07	150	-	4.5	60°	104	180	-	130	(6) M12 x 1.75 x 22
S08	195	-	5.0	22.5°	120	220	-	150	(8) M12 x 1.75 x 22
S09	230	-	5.0	60°	144	280	-	180	(6) M16 x 2.0 x 27
S10	280	-	7.0	36°	167	360	-	210	(10) M16 x 2.0 x 27

S SERIES

AGITATOR UNITS

AGITATOR - Non Standard Special Build.
Please consult our Application Engineers

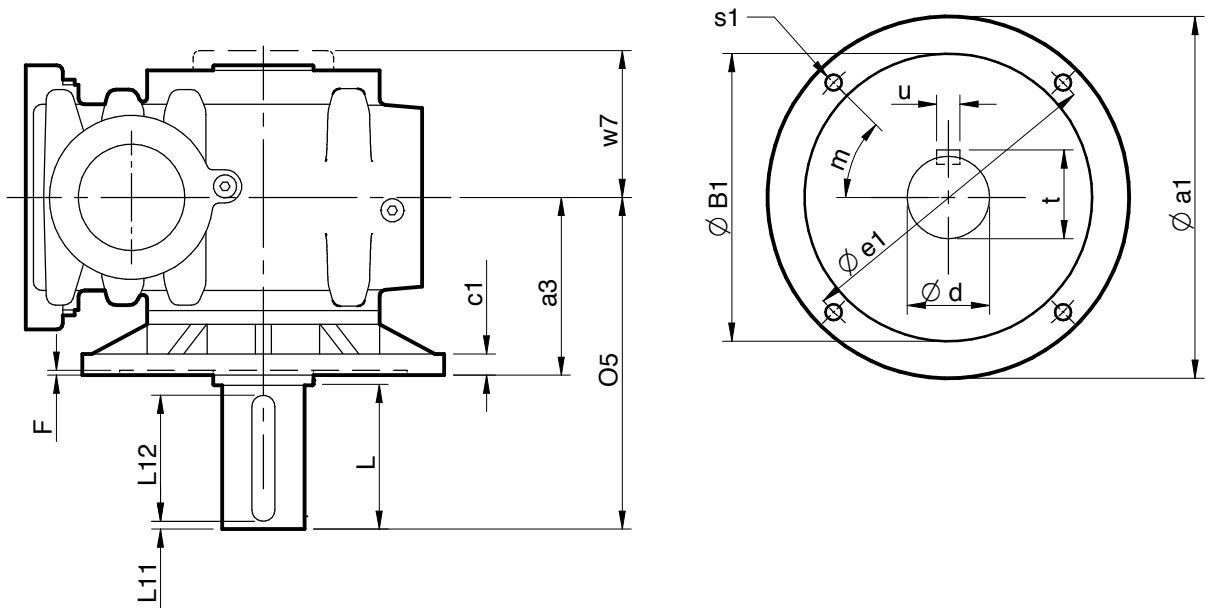

Size	a1	a3	B1 (H7)	c1	d (m6)	e1	F	L	L11	L12	m	O5	S	t	u	w7
S07	300	160	230	16	65	265	6	125	5	110	45°	290	(4) ø 15	69	18	125
S08	350	180	250	17	75	300	7	140	5	125	45°	325	(4) ø 19	79.5	20	143
S09	400	200	300	20	85	350	7	155	5	140	45°	360	(4) ø 19	90	22	169
S10	450	212	350	22	100	400	7	175	5	160	22.5°	392	(8) ø 19	106	28	198

S SERIES

DIMENSIONS

STANDARD BORE ASSEMBLY

ASSEMBLY ONTO SHAFT - CUSTOMERS SHAFT DETAIL

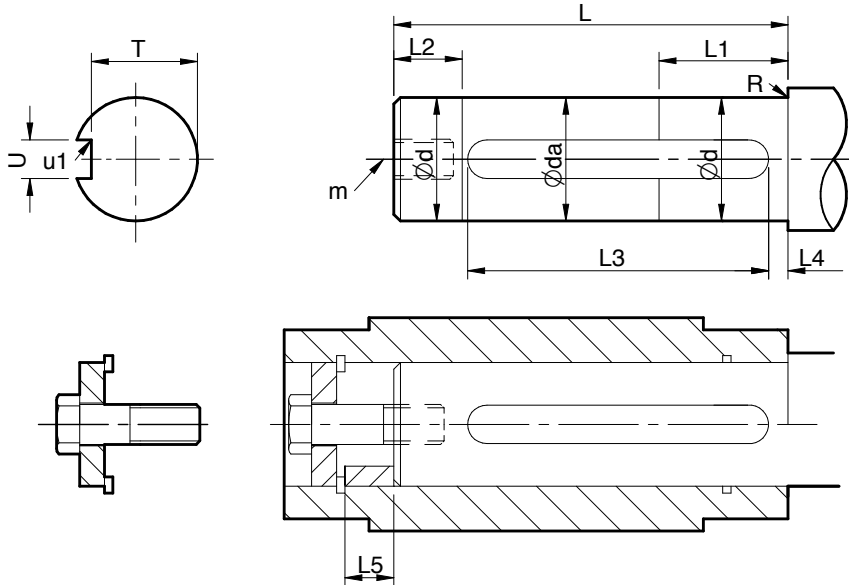

Size	Bore	d	da	L	L1	L2	L3	L4	L5	m	N	R	T	U	u1
S03	Std	19.993/ 19.980	19.6	82	30	10	61.3 61.0	3	22	M6x1.0x16	8 Nm	0.8R	16.5 16.4	6.000 / 5.970	0.16 0.25R
	Reduced	24.993/ 24.980	24.6	99	38	13	79.3 79.0	3	23	M10x1.5x22	15 Nm	0.8R	21.0 20.8	8.000 / 7.964	0.16 0.25R
S04	Std	29.993/ 29.980	29.6	99	45	15	79.3 79.0	3	26	M10x1.5x22	15 Nm	0.8R	26.0 25.8	8.000 / 7.964	0.16 0.25R
	Reduced	29.993/ 29.980	29.6	104	45	15	79.3 79.0	3	23	M10x1.5x22	15 Nm	0.8R	26.0 25.8	8.000 / 7.964	0.16 0.25R
S05	Std	34.991/ 34.975	34.6	104	53	18	77.3 77.0	3	23	M12x1.75x28	20 Nm	0.8R	30.0 29.8	10.000 / 9.964	0.16 0.25R
	Reduced	34.991/ 34.975	34.6	125	60	20	100.5 100.0	3	31	M16x2x36	45 Nm	0.8R	35.0 34.8	12.000 / 11.957	0.4 0.25R
S06	Std	44.991/ 44.975	44.6	125	68	23	101.5 101.0	3	31	M16x2x36	45 Nm	0.8R	39.5 39.3	14.000 / 13.957	0.4 0.25R
	Reduced	49.991/ 49.975	49.6	153	75	25	130.5 130.0	3	35	M16x2x38	45 Nm	1.2R	44.5 44.3	14.000 / 13.957	0.4 0.25R
S07	Std	59.990 / 59.971	59.6	153	90	30	148.5 148.0	3	38	M20x2.5x42	85 Nm	1.2R	53.0 52.8	18.000 / 17.957	0.4 0.25R
	Reduced	59.990 / 59.971	59.6	183	91	31	148.5 148.0	3	37	M20x2.5x42	85 Nm	1.2R	53.0 52.8	18.000 / 17.957	0.4 0.25R
S08	Std	69.990 / 69.971	69.6	183	105	35	177.5 177.0	3	37	M20x2.5x42	85 Nm	1.2R	62.5 62.3	20.000 / 19.94	0.6 80.4R
	Reduced	69.990 / 69.971	69.6	227	105	35	177.5 177.0	3	58	M20x2.5x42	85 Nm	1.2R	62.5 62.3	20.000 / 19.94	0.6 80.4R
S09	Std	89.988 / 89.966	89.6	227	135	45	221.5 221.0	3	58	M24x3.0x50	200 Nm	1.2R	81.0 80.8	25.000 / 24.948	0.6 0.4R
	Reduced	79.990 / 79.971	79.6	260	120	40	225.5 225.0	3	53	M20x2.5x42	85 Nm	1.2R	71.0 70.8	22.000 / 21.946	0.6 0.4R
S10	Std	99.988 / 99.966	99.6	327	150	45	238.5 238.0	10	46	M24x3x50	200 Nm	1.2R	90 89.8	28.000 / 27.948	0.4 0.4R
	Reduced	99.988 / 99.966	99.6	327	150	45	238.5 238.0	10	46	M24x3x50	200 Nm	1.2R	90 89.8	28.000 / 27.948	0.4 0.4R

Assembly Instructions

1. Spray the hollow shaft bore and mating diameter of the output shaft with Rocol DFSM or equivalent antiscuffing spray.
2. Fit key into shaft.
3. Fit the circlip into the output sleeve.
4. Fit the spacer tube only if the output shaft has no shoulder, then fit the output shaft into the output sleeve.
5. Secure in place with the washer and bolt. Torque tighten to the values stated in column N of the above table.
6. Fit plastic protective cover.

S SERIES

DIMENSIONS

STANDARD BORE DISASSEMBLY

DISASSEMBLY METHOD FROM SHAFT

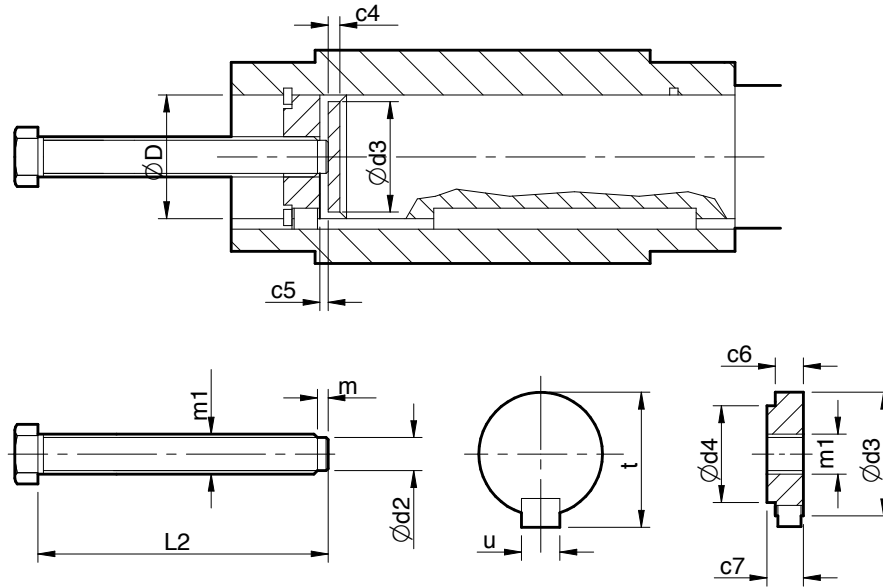

PARTS SUPPLIED BY CUSTOMER

Size	Bore	c4	c6	c7	D (H7)	d2	d3	d4	L2	m	m1	t	u
S03	Std	5	10	12	20	7	19.9	11.2	120	3	M10 x 1.5	22	6
S04	Reduced	5	15	17	25	13	24.9	16.2	160	3	M16 x 2.0	2	8
	Std	5	15	17	30	13	29.9	20.8	160	3	M16 x 2.0	33	8
S05	Reduced	5	15	17	30	13	29.9	20.8	160	3	M16 x 2.0	33	8
	Std	5	15	17	35	13	34.9	25.2	160	3	M16 x 2.0	38	10
S06	Reduced	5	20	23	40	20	39.9	30.9	220	3	M24 x 3.0	43	12
	Std	5	20	23	45	20	44.9	34.1	220	3	M24 x 3.0	49	14
S07	Reduced	5	20	23	50	20	49.9	39.0	220	3	M24 x 3.0	54	14
	Std	8	24	27	60	26	59.9	47.4	250	5	M30 x 3.5	64	1
S08	Reduced	8	24	27	60	26	59.9	47.4	250	5	M30 x 3.5	64	1
	Std	8	24	27	70	26	69.9	58.4	310	5	M30 x 3.5	74.5	20
S09	Reduced	8	24	27	70	26	69.9	58.4	310	5	M30 x 3.5	74.5	20
	Std	8	24	27	90	26	89.9	75.3	360	5	M30 x 3.5	95	25
S10	Reduced	8	24	27	80	26	79.9	65.5	360	5	M30 x 3.5	85	22
	Std	8	30	34	100	32	99.9	84.1	420	5	M30 x 3.5	106	2

S SERIES

SHIPPING SPECIFICATION

BASE MOUNT UNITS WITH STANDARD HOLLOW SHAFT

Unit size & No off reductions		S0321	S0331	S0341	S0421	S0431	S0441	S0521	S0531	S0541	S0621	S0631	S0641	S0721	S0731	S0741	S0821	S0841	S0921	S0941	S1021	S1041	
Reducer Version		11	14	20	15	18	23	18	21	28	32	38	43	74	81	83	117	143	181	204	326	372	
Single Output Shaft		0.4			1.0			1.5			3.7			7.0			12		19		30		
Double Output Shaft		0.6			1.5			2.3			5.6			11			18		28		45		
Motorised	63	Without Motor	12	13	20	16	17	24	18	19	29	28	33	44		80	83						
		With Motor	16	17	25	20	21	29	23	24	33	32	37	48		84	88						
	71	Without Motor	11	13	20	15	17	24	18	19	28	28	33	44		80	83						
		With Motor	18	19	26	22	23	30	25	26	35	34	39	50		87	89						
	80A	Without Motor	12	14	20	16	18	24	19	22	29	31	35	44	71	80	83	118	143	174	204		369
		With Motor	21	23	30	25	27	34	28	31	38	39	43	54	80	88	93	127	152	183	213		37
	80B	Without Motor	12	14	20	16	18	24	19	22	29	31	35	44	71	80	83	118	143	174	204		369
		With Motor	23	25	31	27	29	35	30	33	40	42	46	55	82	91	94	129	154	185	215		380
	90S	Without Motor	13	15	21	16	18	25	19	22	30	32	35	45	72	80	84	118	144	174	205		370
		With Motor	26	28	35	30	32	39	33	36	43	46	50	58	85	94	98	131	157	187	218		383
	90L	Without Motor	13	15	21	16	18	25	19	22	30	32	35	45	72	80	84	118	144	174	205		370
		With Motor	27	29	36	31	33	40	34	37	44	47	52	59	86	95	99	132	158	188	219		34
	100L	Without Motor										35			74			120	146	176	207	313	372
		With Motor										59			98			144	170	200	231	337	396
	112M	Without Motor										35			74			120	146	176	207	313	372
		With Motor										66			105			151	177	207	238	344	403
	132S	Without Motor													76			123		179		316	374
		With Motor													124			171		227		364	422
	132M	Without Motor													76			123		179		316	374
		With Motor													128			175		231		368	426
	160M	Without Motor																128		184		321	
		With Motor																241		297		434	
	160L	Without Motor																128		184		321	
		With Motor																261		317		454	
	180M	Without Motor																		197		334	
		With Motor																		364		501	
	180L	Without Motor																		197		334	
		With Motor																		378		515	
200L	Without Motor																		201		338		
	With Motor																		433		570		
225S	Without Motor																		205		342		
	With Motor																		492		629		
225M	Without Motor																		205		342		
	With Motor																		527		664		

ALL WEIGHTS IN KG ALL WEIGHTS EXCLUDE LUBRICANT AND ARE FOR STANDARD SHAFT MOUNT UNITS, FOR BASE MOUNT UNITS ADD WEIGHT OF SHAFT (SHOWN AT TOP OF TABLE) TO THE FIGURES SHOWN ABOVE

IMPORTANT

Product Safety Information

General - The following information is important in ensuring safety. It **must** be brought to the attention of personnel involved in the selection of the equipment, those responsible for the design of the machinery in which it is to be incorporated and those involved in its installation, use and maintenance.

The equipment will operate safely provided it is selected, installed, used and maintained properly. As with any power transmission equipment **proper precautions must** be taken as indicated in the following paragraphs, to ensure safety.

Potential Hazards - these are **not** necessarily listed in any order of severity as the degree of danger varies in individual circumstances. It is important therefore that the list is studied in its entirety:-

- 1) Fire/Explosion
 - (a) Oil mists and vapour are generated within gear units. It is therefore dangerous to use naked lights in the proximity of gearbox openings, due to the risk of fire or explosion.
 - (b) In the event of fire or serious overheating (over 300 °C), certain materials (rubber, plastics, etc.) may decompose and produce fumes. Care should be taken to avoid exposure to the fumes, and the remains of burned or overheated plastic/rubber materials should be handled with rubber gloves.
- 2) Guards - Rotating shafts and couplings must be guarded to eliminate the possibility of physical contact or entanglement of clothing. It should be of rigid construction and firmly secured.
- 3) Noise - High speed gearboxes and gearbox driven machinery may produce noise levels which are damaging to the hearing with prolonged exposure. Ear defenders should be provided for personnel in these circumstances. Reference should be made to the Department of Employment Code of Practice for reducing exposure of employed persons to noise.
- 4) Lifting - Where provided (on larger units) only the lifting points or eyebolts must be used for lifting operations (see maintenance manual or general arrangement drawing for lifting point positions). Failure to use the lifting points provided may result in personal injury and/or damage to the product or surrounding equipment. Keep clear of raised equipment.
- 5) Lubricants and Lubrication
 - (a) Prolonged contact with lubricants can be detrimental to the skin. The manufacturer's instruction must be followed when handling lubricants.
 - (b) The lubrication status of the equipment must be checked before commissioning. Read and carry out all instructions on the lubricant plate and in the installation and maintenance literature. Heed all warning tags. Failure to do so could result in mechanical damage and in extreme cases risk of injury to personnel.
- 6) Electrical Equipment - Observe hazard warnings on electrical equipment and isolate power before working on the gearbox or associated equipment, in order to prevent the machinery being started.
- 7) Installation, Maintenance and Storage
 - (a) In the event that equipment is to be held in storage, for a period exceeding 6 months, prior to installation or commissioning, application engineering must be consulted regarding special preservation requirements. Unless otherwise agreed, equipment must be stored in a building protected from extremes of temperature and humidity to prevent deterioration.

The rotating components (gears and shafts) must be turned a few revolutions once a month (to prevent bearings brinelling).
 - (b) External gearbox components may be supplied with preservative materials applied, in the form of a "waxed" tape overwrap or wax film preservative. Gloves should be worn when removing these materials. The former can be removed manually, the latter using white spirit as a solvent.

Preservatives applied to the internal parts of the gear units do not require removal prior to operation.
 - (c) Installation must be performed in accordance with the manufacturer's instructions and be undertaken by suitably qualified personnel.
 - (d) Before working on a gearbox or associated equipment, ensure that the load has been removed from the system to eliminate the possibility of any movement of the machinery and isolate power supply. Where necessary, provide mechanical means to ensure the machinery cannot move or rotate. Ensure removal of such devices after work is complete.
 - (e) Ensure the proper maintenance of gearboxes in operation. Use only the correct tools and approved spare parts for repair and maintenance. Consult the Maintenance Manual before dismantling or performing maintenance work.
- 8) Hot Surfaces and Lubricants
 - (a) During operation, gear units may become sufficiently hot to cause skin burns. Care must be taken to avoid accidental contact.
 - (b) After extended running the lubricant in gear units and lubrication systems may reach temperatures sufficient to cause burns. Allow equipment to cool before servicing or performing adjustments.
- 9) Selection and Design
 - (a) Where gear units provide a backstop facility, ensure that back-up systems are provided if failure of the backstop device would endanger personnel or result in damage.
 - (b) The driving and driven equipment must be correctly selected to ensure that the complete machinery installation will perform satisfactorily, avoiding system critical speeds, system torsional vibration, etc.
 - (c) The equipment must not be operated in an environment or at speeds, powers, torques or with external loads beyond those for which it was designed.
 - (d) As improvements in design are being made continually the contents of this catalogue are not to be regarded as binding in detail, and drawings and capacities are subject to alterations without notice.

The above guidance is based on the current state of knowledge and our best assessment of the potential hazards in the operation of the gear units.

Any further information or clarification required may be obtained by contacting an Application Engineer.

RENOLD

A global power transmission group serving global markets through an international network.

For your local Renold sales and service location visit www.renold.com

Superior Technology. Global Expertise.

www.renold.com

gears.sales@renold.com



REN104/CAT-SSERIES/10.16/E
A Business of Renold Power Transmission Ltd.

RENOLD
Superior Gear Technology